



Surname _____

Other Names _____

Centre Number _____

Candidate Number _____

Candidate Signature _____

GCSE

MATHEMATICS

F

Foundation Tier Paper 2 Calculator

8300/2F

Thursday 8 June 2017 Morning

Time allowed: 1 hour 30 minutes

For this paper you must have:

- a calculator
- mathematical instruments.

At the top of the page, write your surname and other names, your centre number, your candidate number and add your signature.

[Turn over]



JUN178300/2F01

INSTRUCTIONS

- **Use black ink or black ball-point pen. Draw diagrams in pencil.**
- **Answer ALL questions.**
- **You must answer the questions in the spaces provided. Do NOT write on blank pages.**
- **Do all rough work in this book. Cross through any work you do not want to be marked.**



INFORMATION

- **The marks for questions are shown in brackets.**
- **The maximum mark for this paper is 80.**
- **You may ask for more answer paper, graph paper and tracing paper. These must be tagged securely to this answer book.**

ADVICE

- **In all calculations, show clearly how you work out your answer.**

**DO NOT TURN OVER UNTIL TOLD
TO DO SO**



Answer ALL questions in the spaces provided

- 1 Which unit is most suitable for measuring the length of a tennis court?**

Circle your answer. [1 mark]

kilometres

metres

centimetres

millimetres

- 2 Circle the multiple of both 8 and 12 [1 mark]**

4

32

72

108

- 3 What is $\frac{3}{2}$ as a decimal?**

Circle your answer. [1 mark]

1.05

1.1

1.5

3.2



5

- 4 Circle the correct statement.
[1 mark]

$$-4 < -3 \quad 1 \leq -2 \quad -6 > 5 \quad -1 \geq 0$$

- 5 (a) Use your calculator to work out $\sqrt{701}$ as a decimal.

Write down your full calculator display. [1 mark]

Answer _____

- 5 (b) Give your answer to part (a) to 1 decimal place. [1 mark]

Answer _____

[Turn over]



6 A swimming pool has three changing rooms, Male, Female and Family.

The pictogram shows the number of people using each changing room during one hour.

Key:  represents _____ people

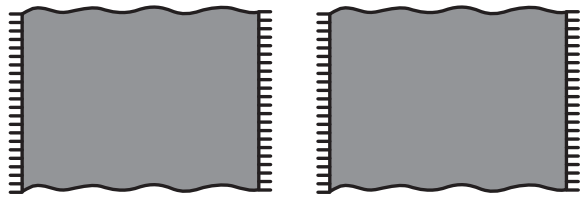
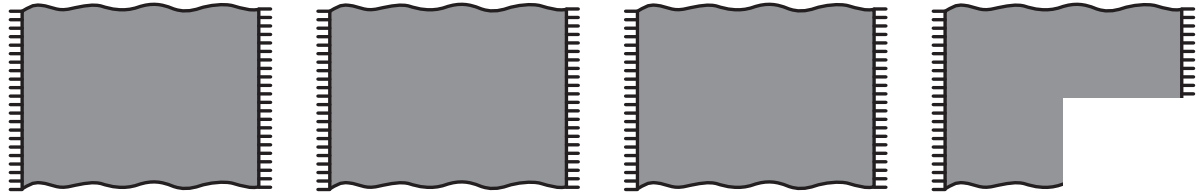
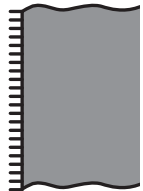
Male	
Female	
Family	

8 people used the Male changing room.

6 (a) Complete the key. [1 mark]



**6 (b) How many people used the Female changing room?
[1 mark]**

Answer _____

[Turn over]



6 (c) The manager has bought lockers for the changing rooms.

Why should she NOT use these results to decide where to put them? [1 mark]



7 Here is a list of numbers.

21 17 23 21 29 32 21 25 36

Work out the median. [2 marks]

Answer _____

5

[Turn over]



8 Here is a map of a town.
Scale: 2 cm represents 200 m

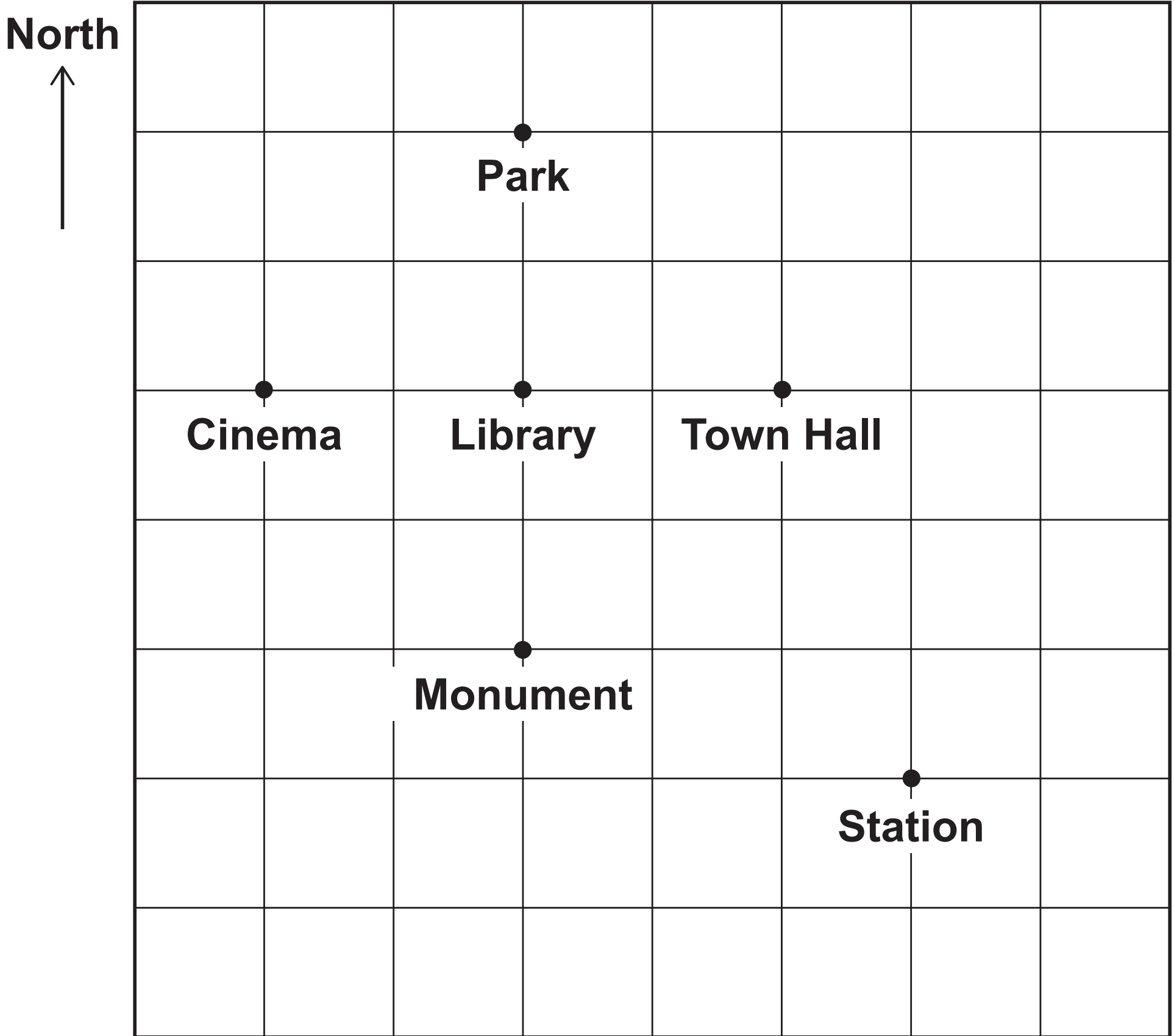

8 (a) Which place is exactly North West of the Station?

Circle your answer. [1 mark]

Cinema

Town Hall

Library

Park

Monument

8 (b) Circle the three-figure bearing of the Monument from the Park. [1 mark]

090°

180°

270°

360°

[Turn over]



**8 (c) What is the distance, in metres, from the Cinema to the Station?
[3 marks]**

Answer _____ metres



8 (d) Why might the shortest WALKING distance from the Cinema to the Station be greater than your answer to part (c)?
[1 mark]

6

[Turn over]





9 Complete the bank statement. [2 marks]

Date	Description	Credit (£)	Debit (£)	Balance (£)
13/12/2016	Starting balance			212.48
14/12/2016	Council tax		128.39	_____
15/12/2016	Salary	856.21		_____

10 **The average age of teachers at a school is 36 years.**

Mr Smith's age is $\frac{11}{9}$ of the average.

How old is Mr Smith? [2 marks]

Answer _____ years

[Turn over]



11 Solve $4x - 3 = 14$ [2 marks]

$x =$

6



12 Lee sells ice creams.

The table shows the midday temperature and his sales for five days.

	Day 1	Day 2	Day 3	Day 4	Day 5
Temperature (°C)	30	26	17	22	20
Sales (£)	180	150	80	130	120

[Turn over]



12 (a) He draws this scatter graph and line of best fit.

Ice cream sales and temperature

Sales (£)

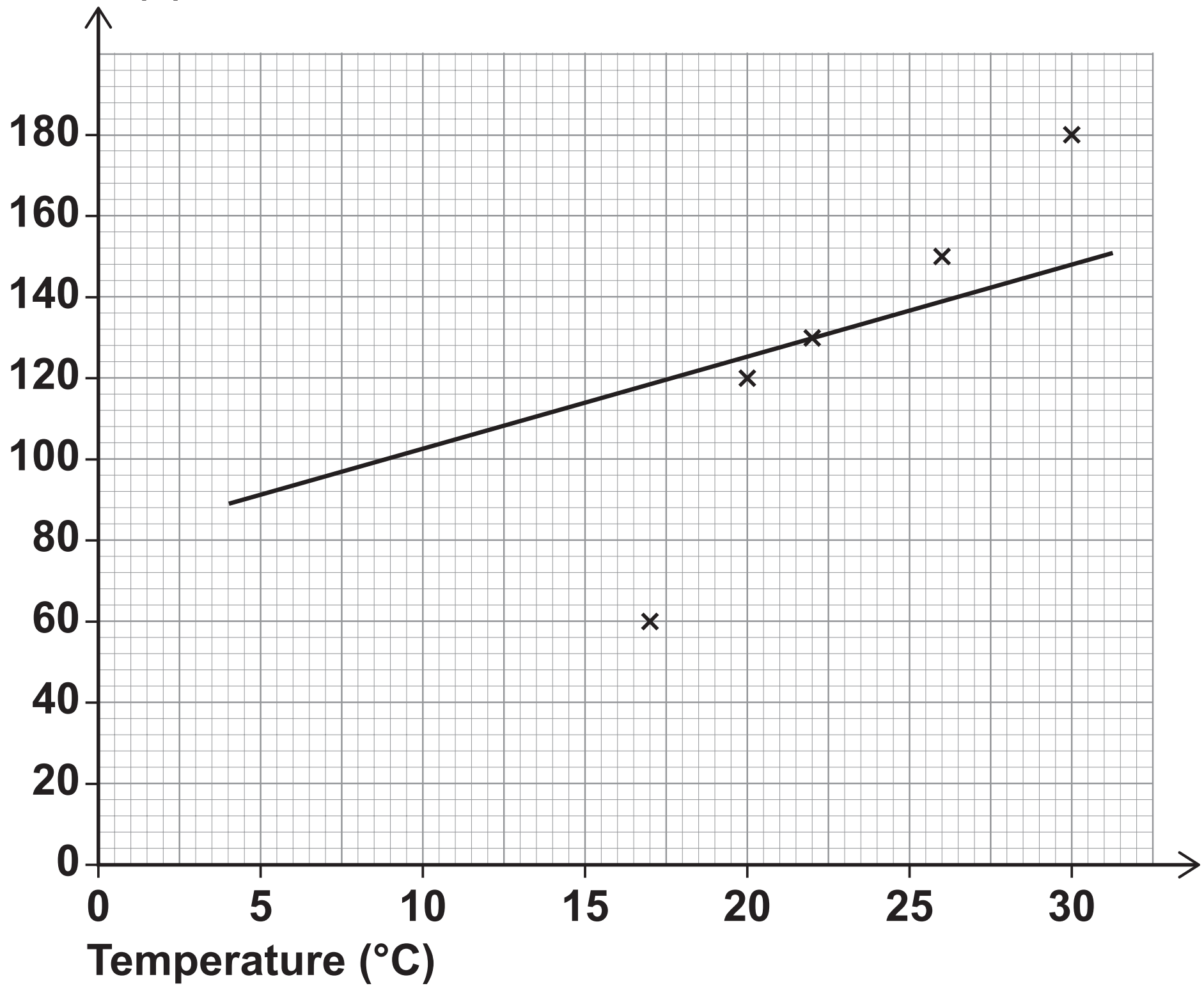

Write down TWO mistakes he has made. [2 marks]

Mistake 1 _____

Mistake 2 _____

[Turn over]



12 (b) Lee wants to work out the range of the five temperatures.

His calculation is $30 - 20 = 10$

Is his method correct?

Tick a box. [1 mark]

Yes

No

Give a reason to support your answer.



12 (c) The table shows Lee's costs.

Ingredients	15% of sales
Fuel	£7 per day

Work out his total profit for the five days. [5 marks]

[Turn over]



Answer £ _____

8



13

Not drawn accurately

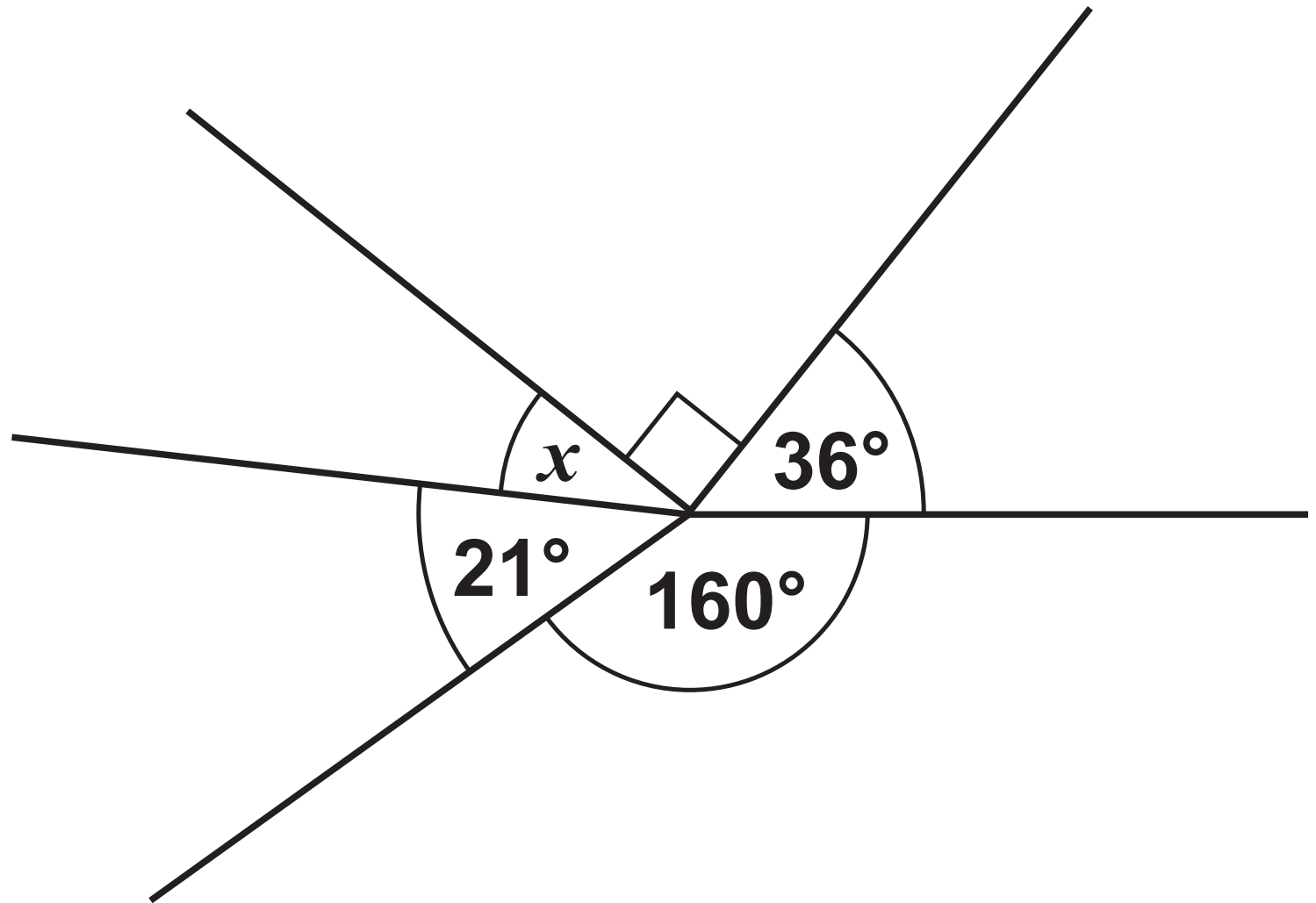

Work out the size of angle x .
[2 marks]

[Turn over]



24

Answer _____ **degrees**



14 In this question, use

1 kilogram = 2.2 pounds

1 stone = 14 pounds

Change 70 kilograms into stones. [3 marks]

Answer _____ stones

[Turn over]



15 Here are some numbers.

10 13 15 20 27 39

10 15 20 is an arithmetic progression.

Use **THREE** of the numbers to make a different arithmetic progression.

Describe the rule. [2 marks]

Answer _____

Rule _____

7



16 The counters in a bag are red or blue.

One fifth of the counters are red.

**Work out the ratio
red counters : blue counters**

Circle your answer. [1 mark]

1:4

1:5

4:5

1:6

17 Circle the fraction equal to 0.1%
[1 mark]

$$\frac{1}{10}$$

$$\frac{1}{100}$$

$$\frac{1}{1000}$$

$$\frac{1}{10000}$$

[Turn over]



18 Ellen works for a company that sells cars.

Her MONTHLY pay is

- **a salary of £1470**
- **28% of the total PROFIT the company makes from her sales**
- **a £250 bonus IF she sells at least 15 cars.**

The table shows information about the cars she sold last year.

Total cost to the company	£464 500
Total income for the company	£538 000
Number of months when she sold at least 15 cars	3

Was Ellen's total pay for the YEAR more than £40 000?

**You MUST show your working.
[6 marks]**



19 Ben and Katy throw darts at a target.

Ben's ratio of hits to misses is 5:1

Katy's ratio of hits to misses is 3:1

Ben says,

“5 is bigger than 3, so I must have more hits than Katy.”

**Give an example to show that this might NOT be true.
[2 marks]**

[Turn over]



20 A code has 4 digits.
Each digit is a number from 0 to 9
Digits may be repeated.

The code starts 5 4 1

20 (a) Joe chooses a number at random
for the last digit.

Write down the probability that
he chooses the correct number.
[1 mark]

Answer _____



20 (b) Amy knows the last digit is odd but NOT 7

She chooses a different odd number at random.

**What is the probability that she chooses the correct number?
[1 mark]**

Answer _____

4

[Turn over]



21 Eva thinks she can save water by having a shower instead of a bath.

**Eva's shower
uses 10·8 litres per minute
lasts for 8 minutes.**

Eva assumes that the water in her bath is in the shape of the cuboid below. The cuboid has dimensions 110 cm long by 50 cm wide by 35 cm high.

1000 cm³ = 1 litre

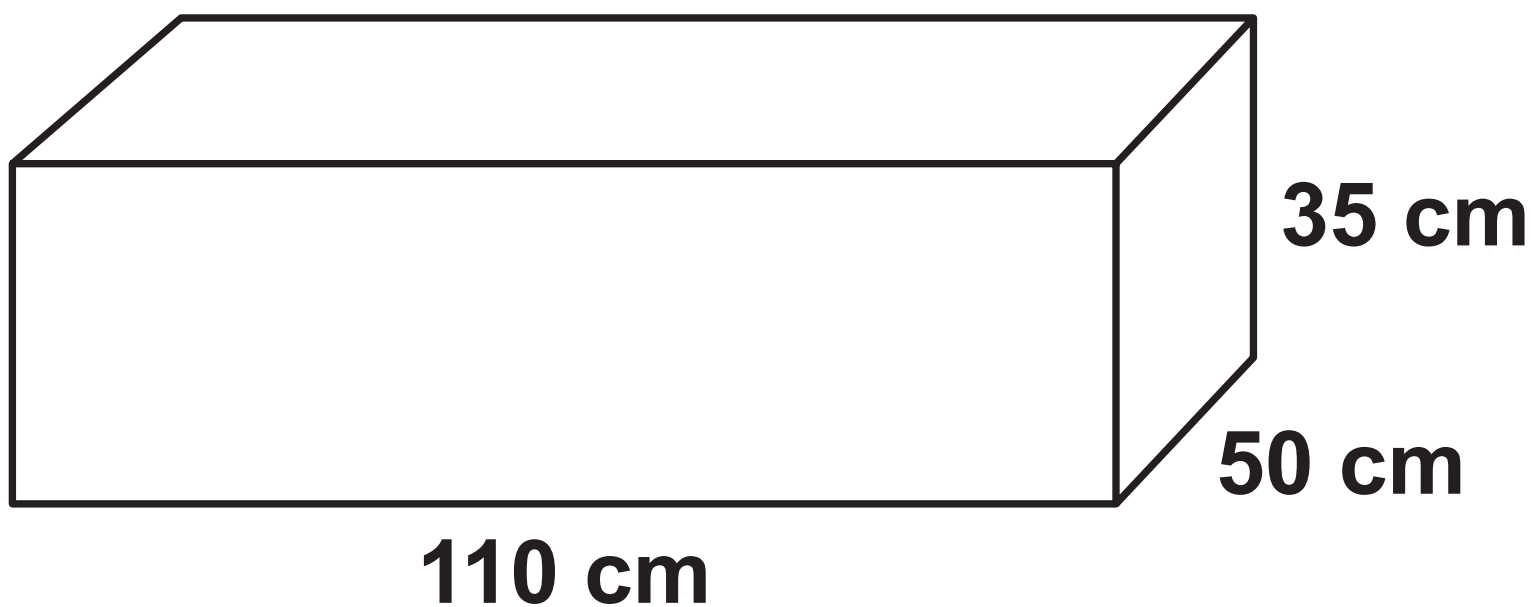

21 (b) *A* shows the water level before Eva gets into the bath.

B shows the cuboid in the empty bath.

Not drawn accurately



A

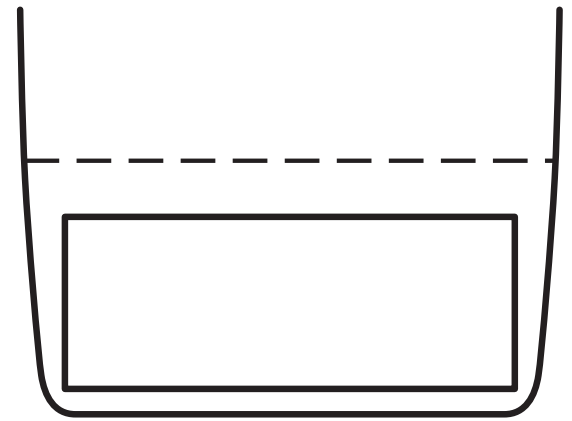

B

What does this tell you about the amount of water saved?
[1 mark]



BLANK PAGE

[Turn over]



22

Not drawn accurately

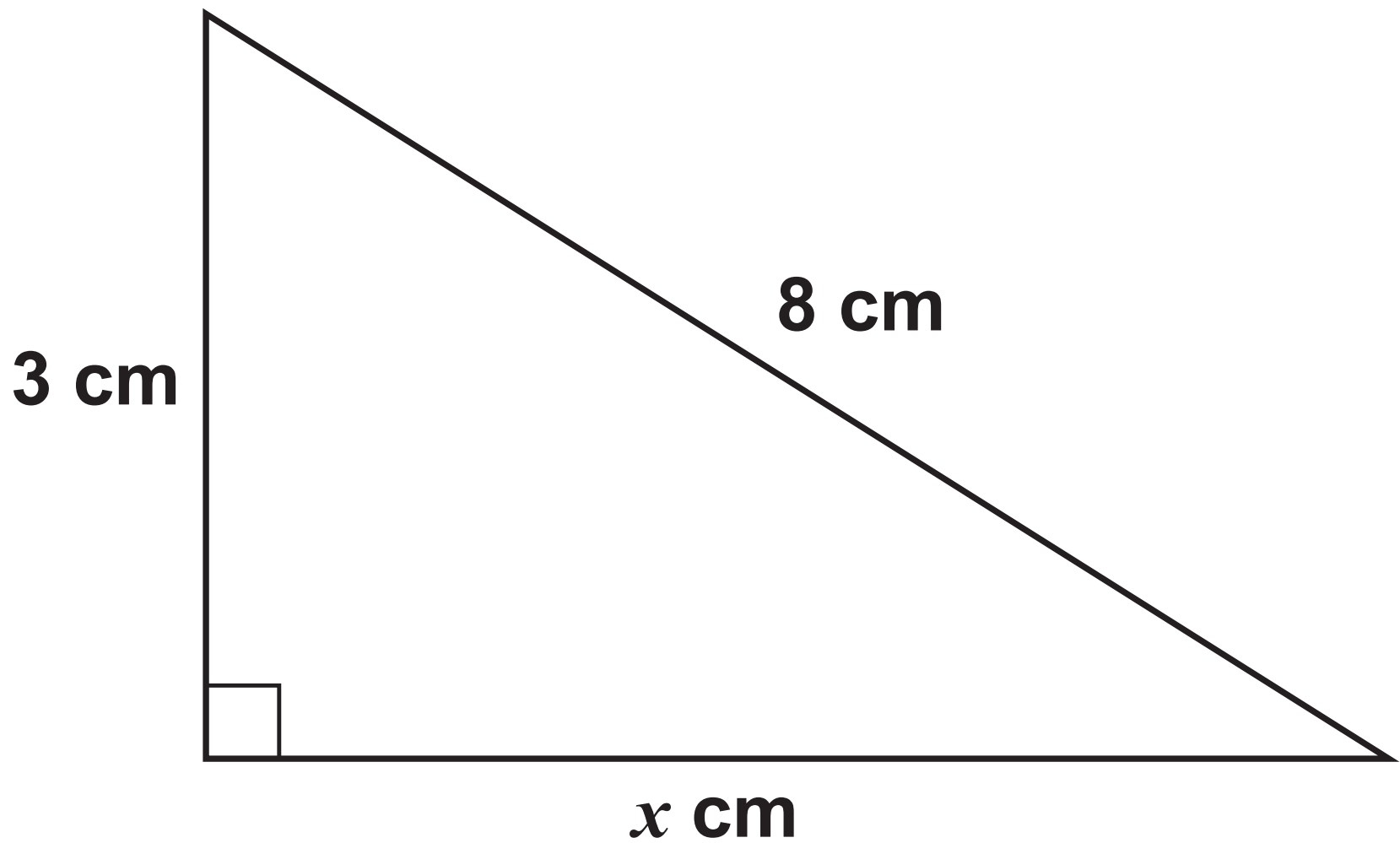

Work out the value of x as a decimal. [3 marks]



Answer _____

[Turn over]



23 Lily goes on a car journey.

**For the first 30 minutes
her average speed is
40 miles per hour.**

She then stops for 15 minutes.

**She then completes the
journey at an average speed of
60 miles per hour.**

The total journey time is 1 hour.



23 (a) Draw a distance-time graph for her journey. [3 marks]

Distance travelled (miles)

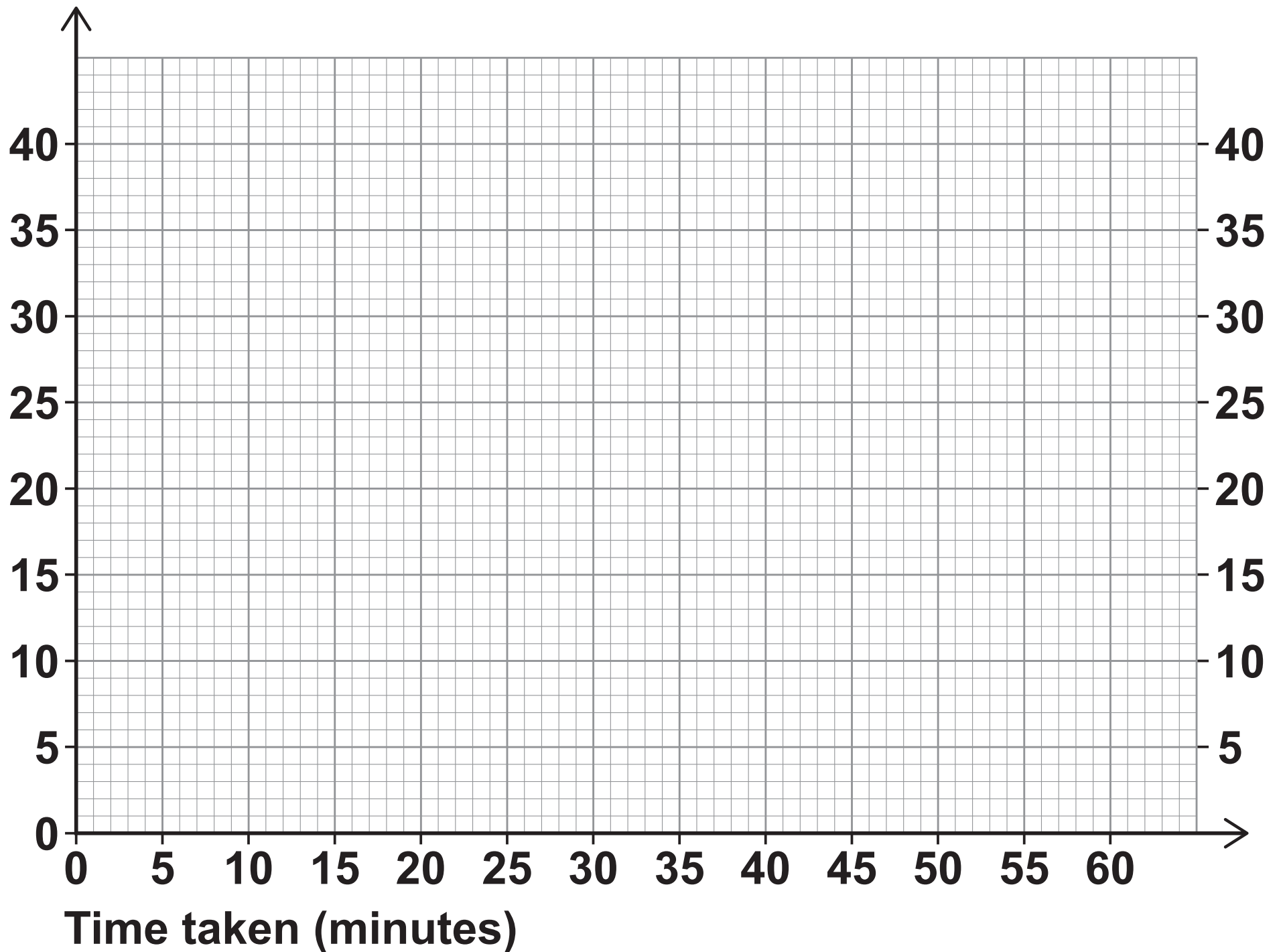

23 (b) Write down the average speed for the total journey. [1 mark]

Answer _____ mph

7

[Turn over]



24

The pie chart shows information about voters in an election.

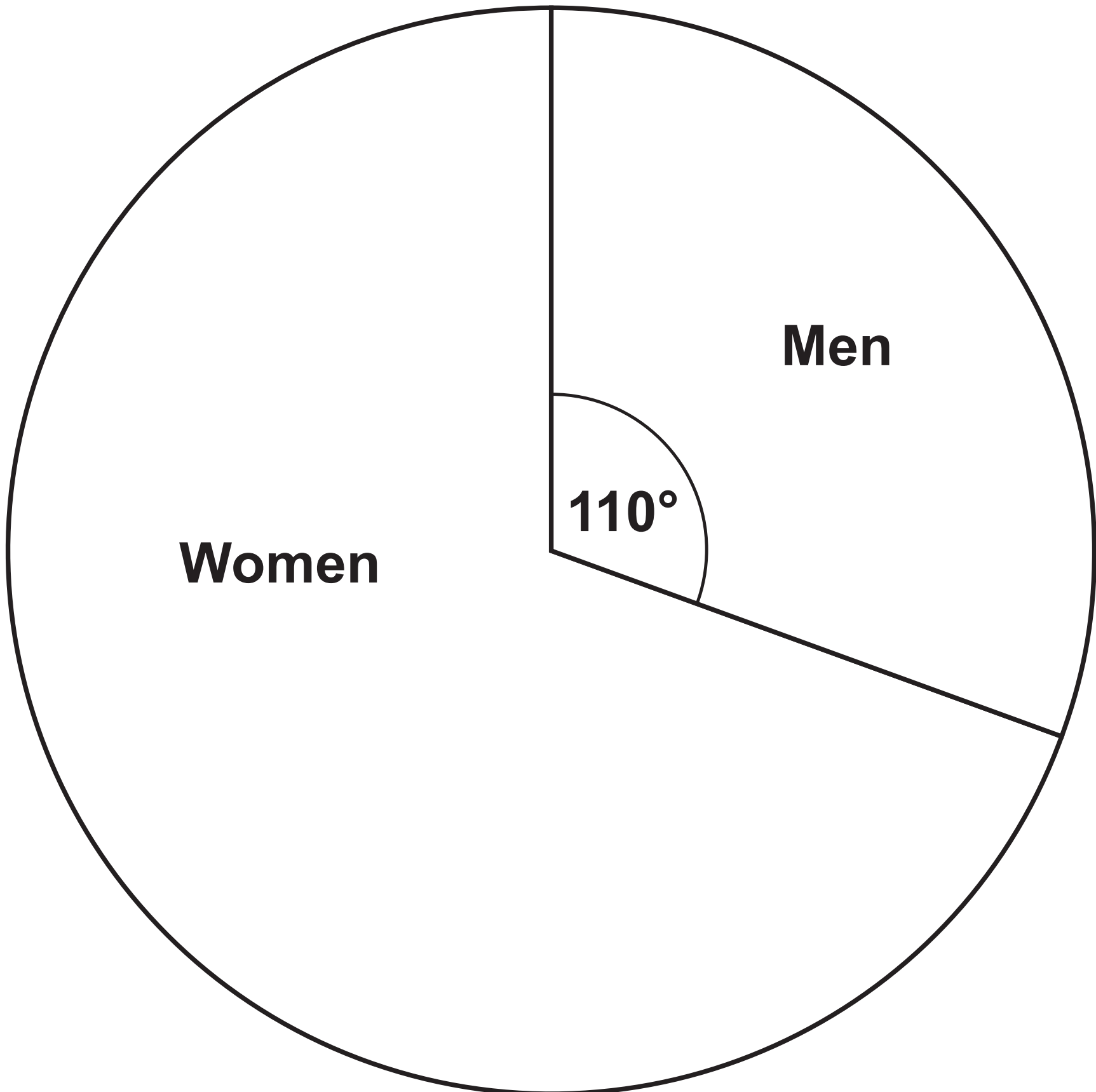
VOTERS

3360 MORE women voted than men.

Work out the total number of voters. [3 marks]



- 25** The table shows information about some CDs.

Type	Rock	Pop	Jazz
Number of CDs	2	x	$2x + 5$

A CD is chosen at random.

The probability it is ROCK is $\frac{1}{20}$

Work out the probability it is jazz. [4 marks]



45

Answer _____

7

[Turn over]



26 (a) Complete the table of values for $y = x^2 - x - 2$ [2 marks]

x	-2	-1	0	1	2	3
y			-2	-2		4

26 (b) Draw the graph of $y = x^2 - x - 2$ for values of x from -2 to 3 [2 marks]

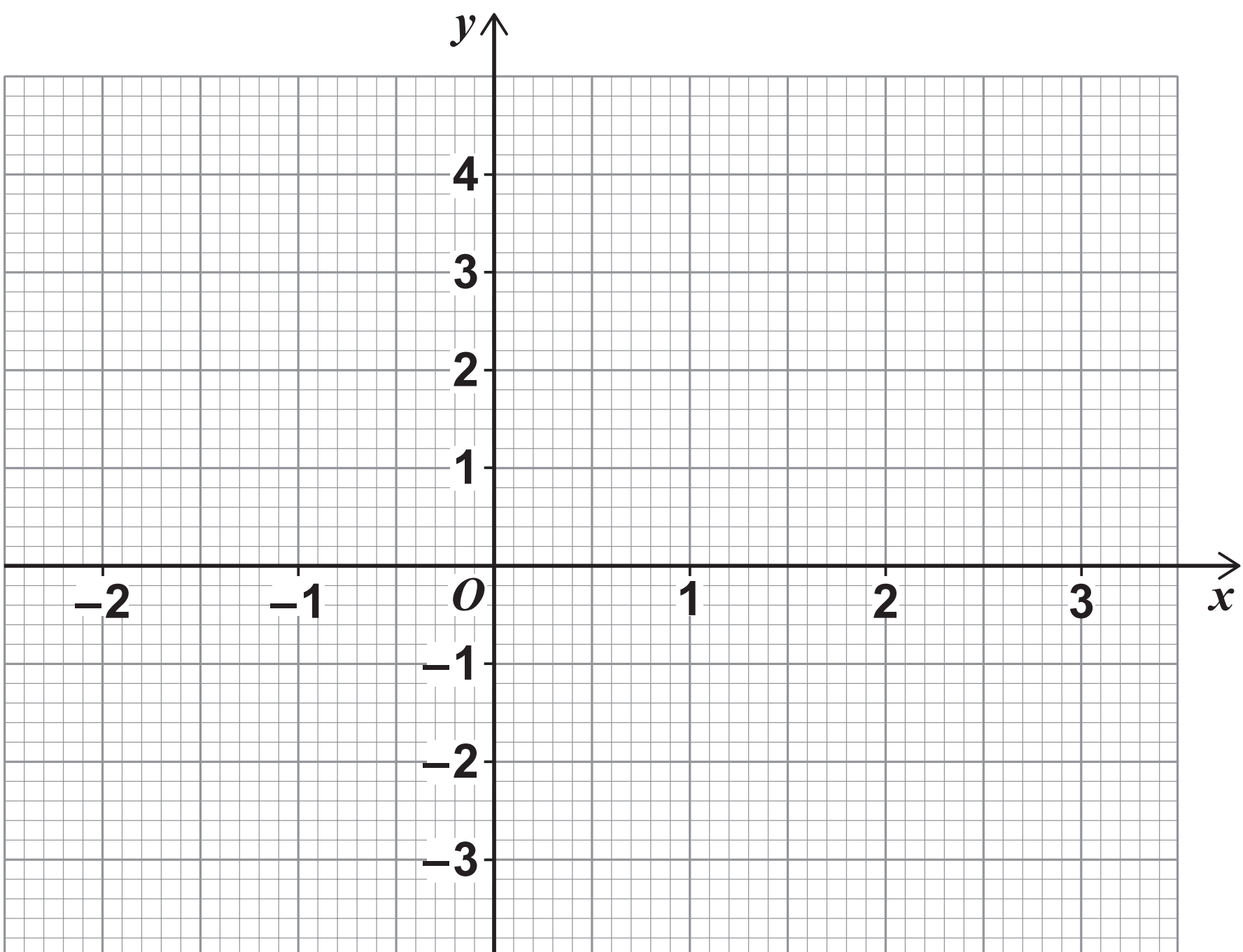

27 Write these numbers in
DESCENDING order.

9563

 9.56×10^3 9.56×3^{10}

[2 marks]

Answer _____, _____, _____

[Turn over]



28 Rearrange $y = \frac{x}{3} + 9$ to make x
the subject. [2 marks]

Answer _____

8



BLANK PAGE

[Turn over]



29

Use trigonometry to work out the length x . [2 marks]

Not drawn accurately

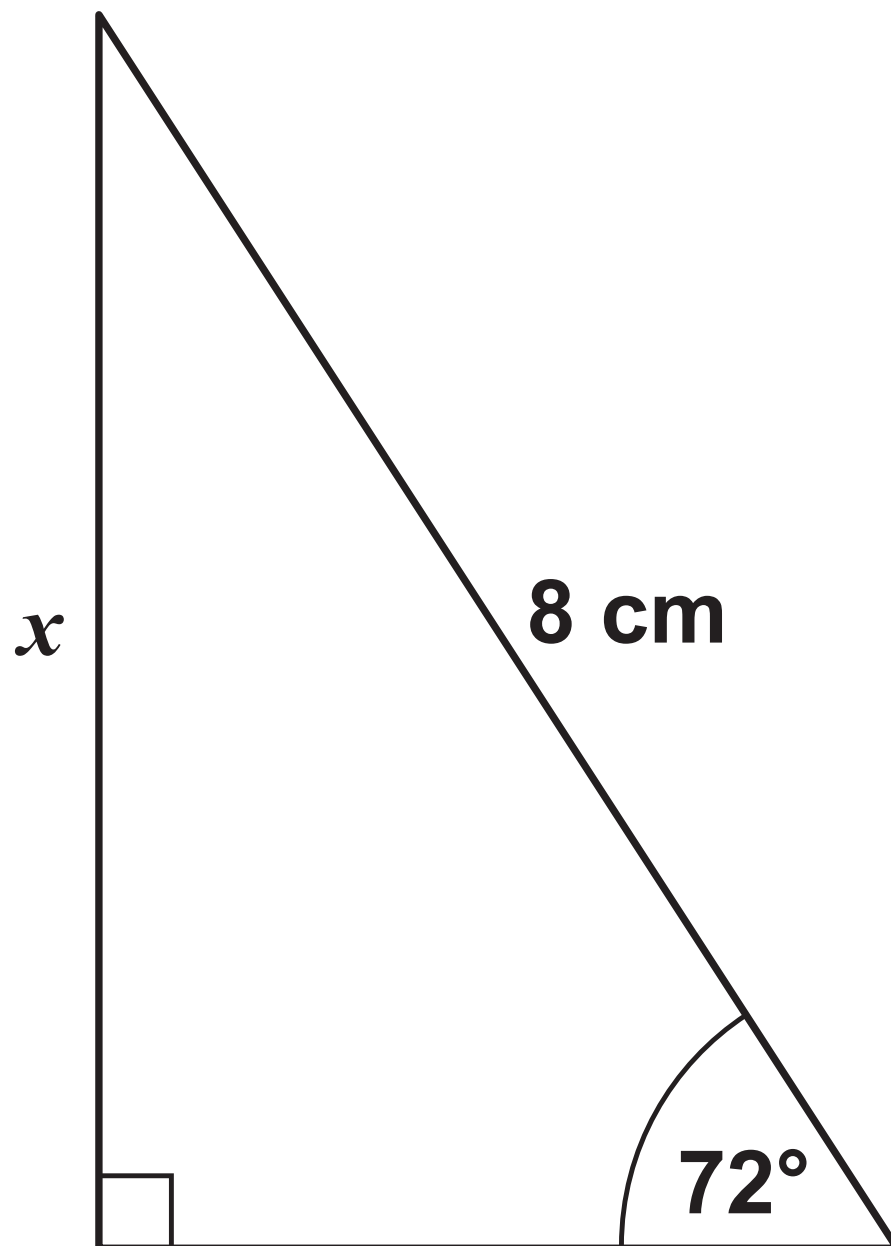



Answer _____ cm

2

END OF QUESTIONS



BLANK PAGE

For Examiner's Use	
Pages	Mark
4 – 5	
6 – 9	
10 – 13	
14 – 16	
17 – 22	
23 – 26	
27 – 29	
30 – 33	
34 – 36	
37 – 41	
42 – 45	
46 – 48	
49 – 51	
TOTAL	

Copyright information

For confidentiality purposes, from the November 2015 examination series, acknowledgements of third party copyright material will be published in a separate booklet rather than including them on the examination paper or support materials. This booklet is published after each examination series and is available for free download from www.aqa.org.uk after the live examination series.

Permission to reproduce all copyright material has been applied for. In some cases, efforts to contact copyright-holders may have been unsuccessful and AQA will be happy to rectify any omissions of acknowledgements. If you have any queries please contact the Copyright Team, AQA, Stag Hill House, Guildford, GU2 7XJ.

Copyright © 2017 AQA and its licensors. All rights reserved.

PB/Jun17/8300/2F/E1

