



Surname _____

Other Names _____

Centre Number _____

Candidate Number _____

Candidate Signature _____

GCSE MATHEMATICS

H

Higher Tier Paper 3 Calculator

8300/3H

Wednesday 8 November 2017

Morning

Time allowed: 1 hour 30 minutes

For this paper you must have:

- a calculator
- mathematical instruments.

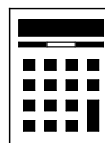

At the top of the page, write your surname and other names, your centre number, your candidate number and add your signature.

[Turn over]



BLANK PAGE



INSTRUCTIONS

- Use black ink or black ball-point pen. Draw diagrams in pencil.
- Answer ALL questions.
- You must answer the questions in the spaces provided. Do not write on blank pages.
- Do all rough work in this book. Cross through any work you do not want to be marked.

INFORMATION

- The marks for questions are shown in brackets.
- The maximum mark for this paper is 80.
- You may ask for more answer paper, graph paper and tracing paper.
These must be tagged securely to this answer book.

ADVICE

- In all calculations, show clearly how you work out your answer.

DO NOT TURN OVER UNTIL TOLD TO DO SO



Answer ALL questions in the spaces provided.

- 1 Circle the inequality shown by the diagram.
[1 mark]

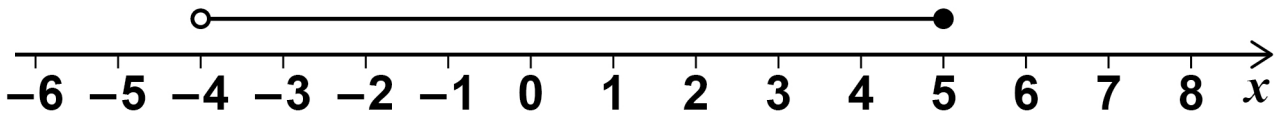

$$-4 \leq x < 5$$

$$-4 \leq x \leq 5$$

$$-4 < x < 5$$

$$-4 < x \leq 5$$

- 2 y is 100% MORE than x .

Circle the ratio $x : y$ [1 mark]

$$1 : 100$$

$$100 : 1$$

$$1 : 2$$

$$2 : 1$$

- 3 The first four terms of a sequence are
-10 -8 -6 -4

Circle the expression for the n th term of the sequence. [1 mark]

$$-12 - 2n$$

$$-8 - 2n$$

$$n + 2$$

$$2n - 12$$



- 7 Here is some information about the times taken by 40 people to fill in a form.

Time, t minutes	Number of people
$0 < t \leq 5$	3
$5 < t \leq 10$	9
$10 < t \leq 15$	11
$15 < t \leq 20$	17

In which class interval is the median?

Circle your answer. [1 mark]

$$0 < t \leq 5$$

$$5 < t \leq 10$$

$$10 < t \leq 15$$

$$15 < t \leq 20$$

[Turn over]



- 8 *ABCD* is a parallelogram.
It is not drawn accurately.

$AB = BP$

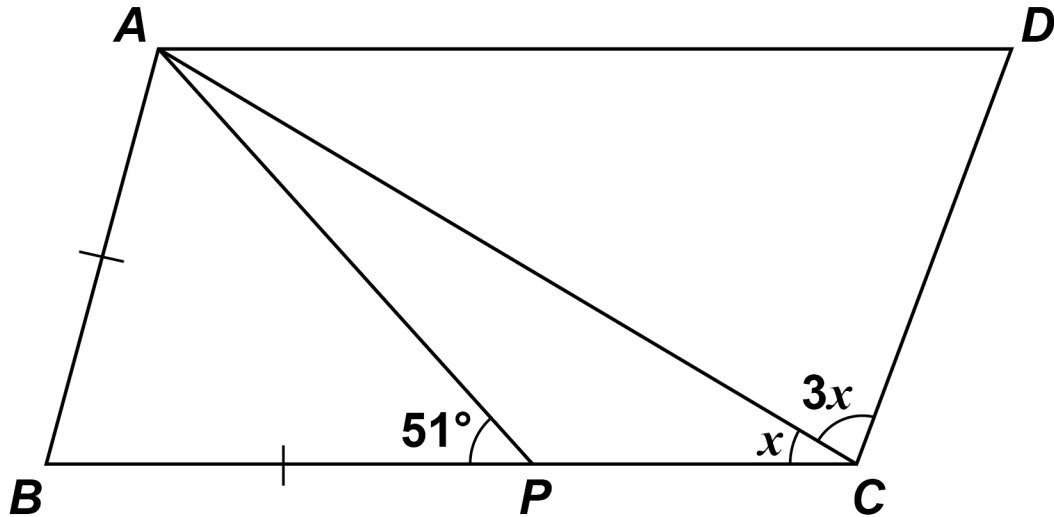

Work out the size of angle x . [4 marks]



Answer _____ degrees

7

[Turn over]



- 9 (a) Rearrange $v = u + at$ to make t the subject of the formula. [2 marks]

Answer _____

- 9 (b) Complete this table with consistent metric units. [2 marks]

Distance	Time	Speed	Acceleration
m	s		



- 10 Construct a locus of points that are the same distance from points *A* and *B*. [2 marks]

•

A

•

B

[Turn over]

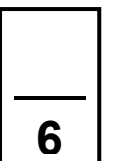

- 11 42 men and 38 women visit a restaurant.
44 of these people have a voucher.
Three times as many men as women do NOT
have a voucher.

11 (a) Complete the frequency tree. [4 marks]

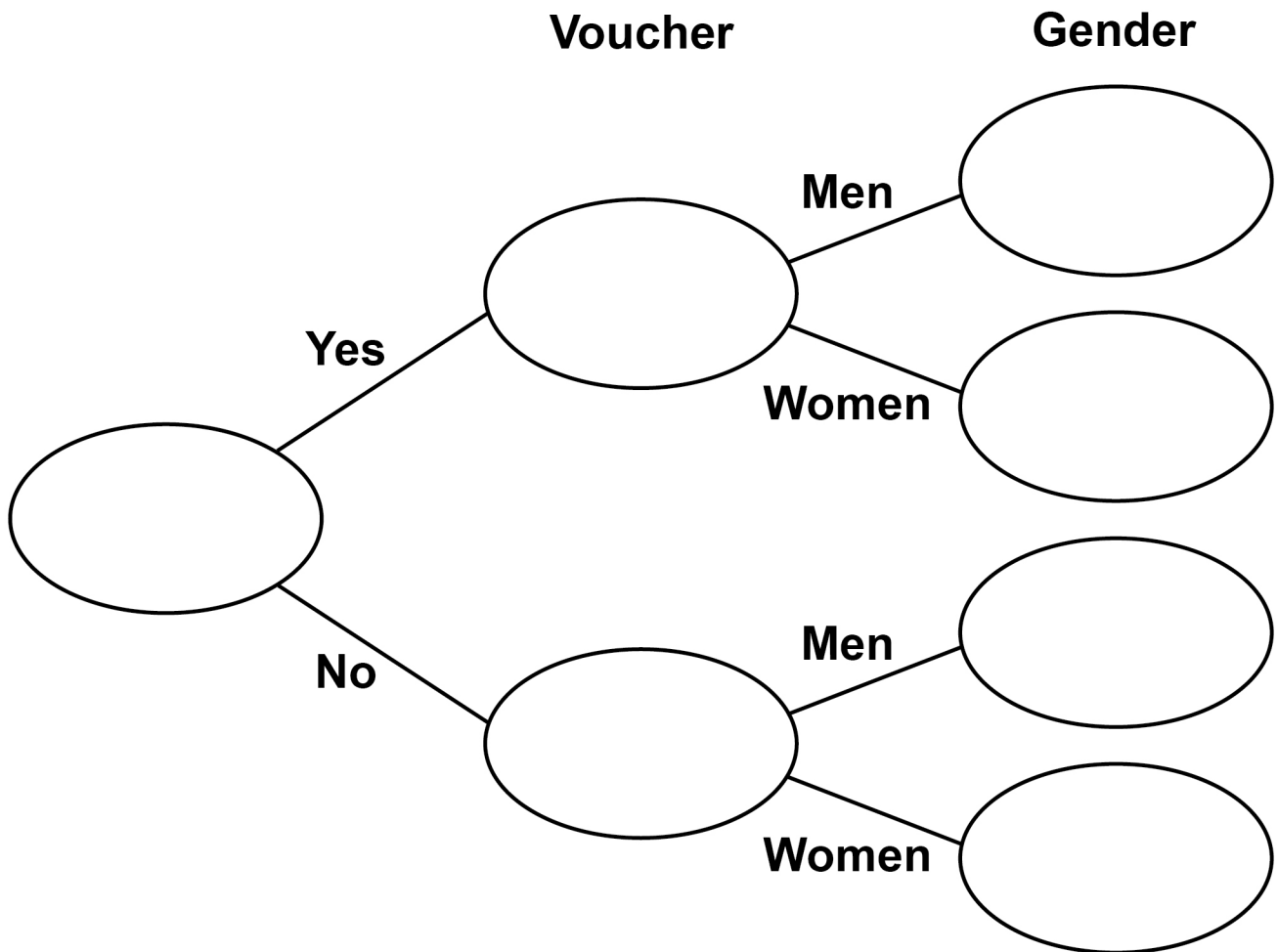

12 (b) In fact, the coach has a lower average speed.

How does this affect the arrival time? [1 mark]

[Turn over]



BLANK PAGE



13 Here is some information about the length of time cars stayed in a car park.

Shortest time	30 minutes	Lower quartile	2 hours
Longest time	12 hours	Interquartile range	3 hours
		Median time	4 hours

Draw a box plot to show this information. [3 marks]

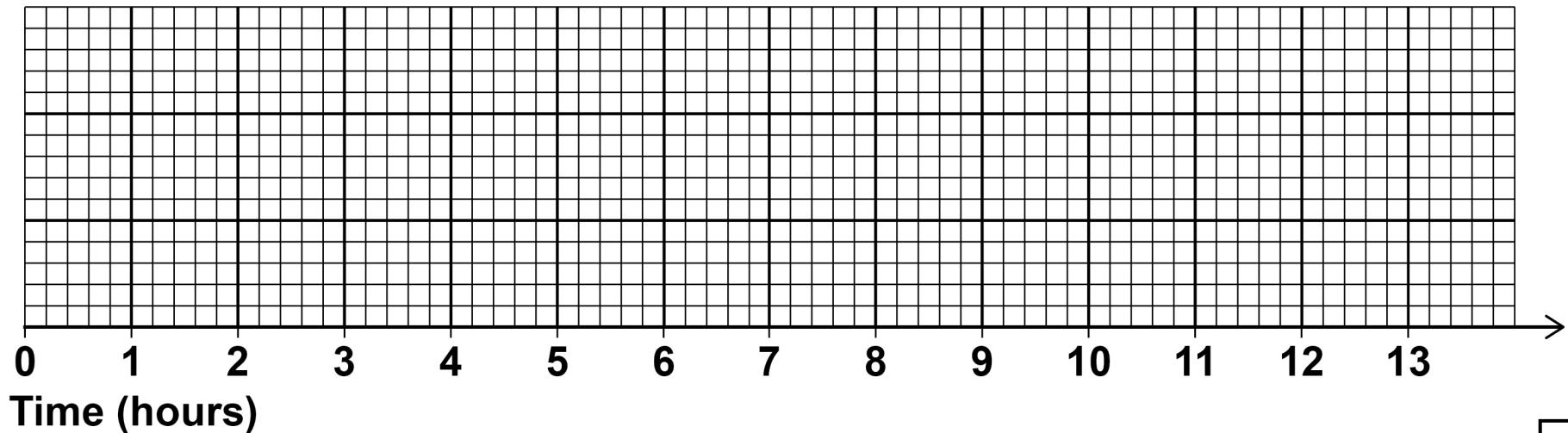

[Turn over]

7



- 14 In the Venn diagram
 ξ represents 31 students in a class
 C is students who have a cat
 D is students who have a dog

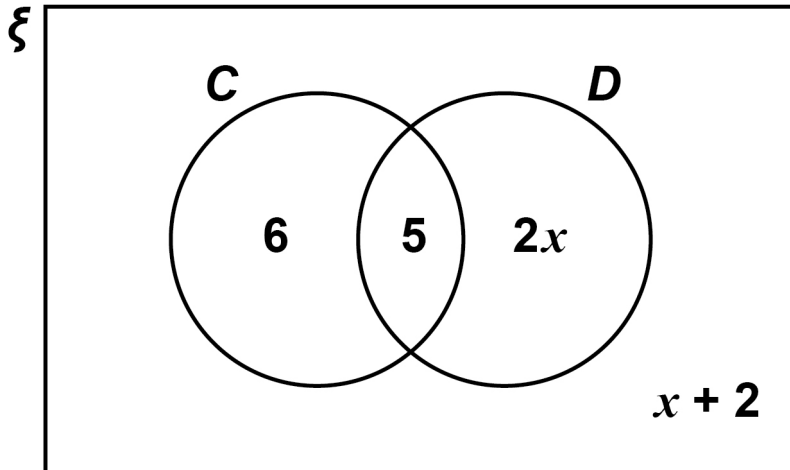

- 14 (a) One student from the class is picked at random.
 Work out the probability that the student has a dog. [3 marks]

Answer _____



14 (b) One of the students who has a cat is picked at random.

Work out the probability that this student has a dog. [1 mark]

Answer _____

[Turn over]



- 15 Circle the highest common factor (HCF) of $6xy^2$ and $4x^3y$ [1 mark]

$2xy^2$

$2xy$

$12x^3y^2$

$24x^4y^3$

- 16 $f(x) = x^2 - x^3$

Circle the value of $f(-3)$ [1 mark]

18

-18

36

-36

6



- 19 A , B and C are points on a circle.
It is not drawn accurately.
 CD is a tangent to the circle.

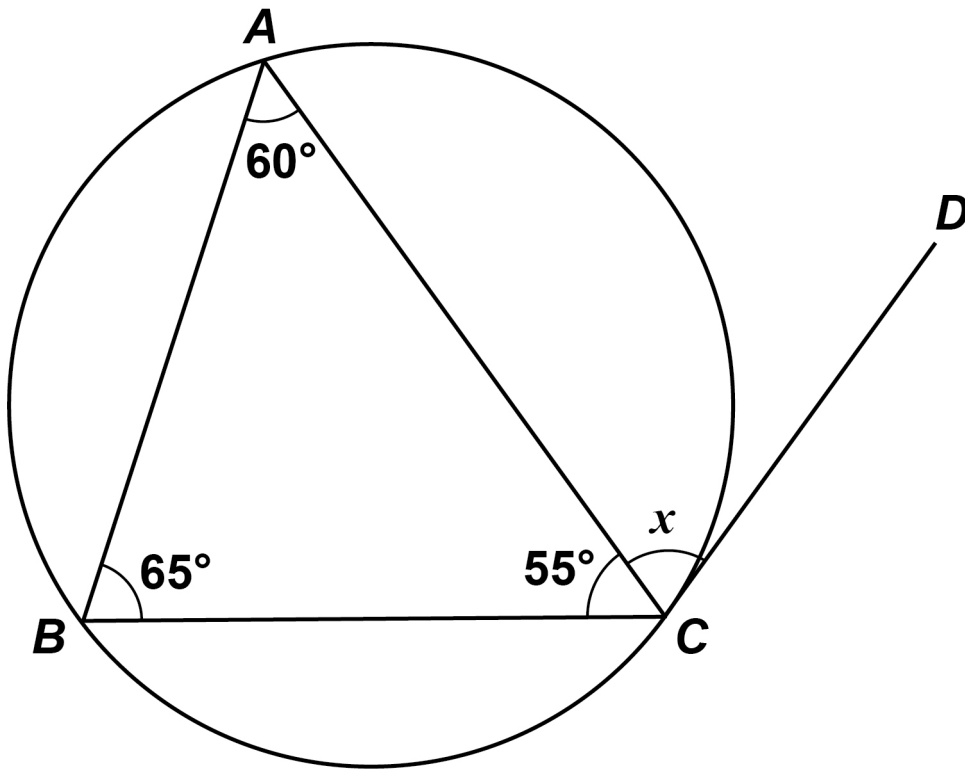

Write down the size of angle x .

Give a reason for your answer. [2 marks]

Answer _____ degrees

Reason _____

9

[Turn over]



20 w is a positive number.

x is 10% more than w .

y is 10% less than x .

Which statement is true?

Tick ONE box. [1 mark]

$w < x$ and $w < y$

$w < x$ and $w = y$

$x > y$ and $w > y$

$x > y$ and $w = y$



22 Here is a triangle.

It is not drawn accurately.

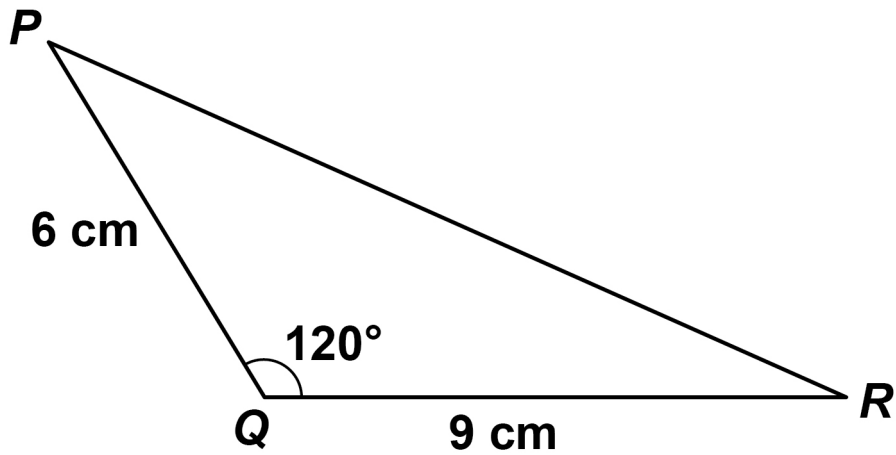

Work out the length PR . [3 marks]

Answer _____ cm

7



BLANK PAGE

[Turn over]



- 23 Joe draws this graph to identify the region R represented by

$$y \leq x + 2 \quad \text{and} \quad y > 3 - x \quad \text{and} \quad x < 3$$

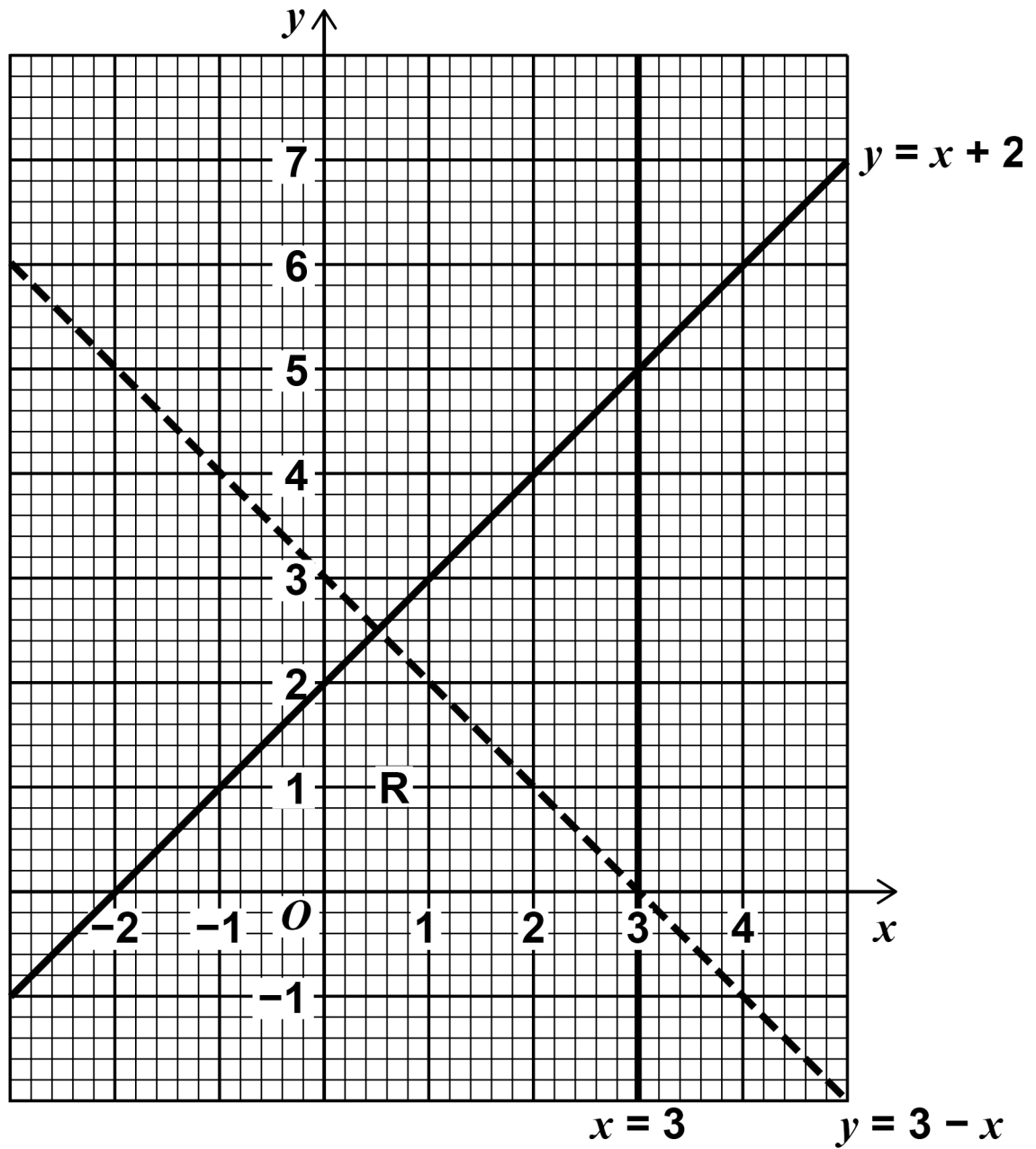

Make TWO criticisms of his graph. [2 marks]

Criticism 1 _____

Criticism 2 _____

[Turn over]



BLANK PAGE

[Turn over]



- 25 Liquid is leaking out of a container.
The graph shows the depth of the liquid for 60 seconds.

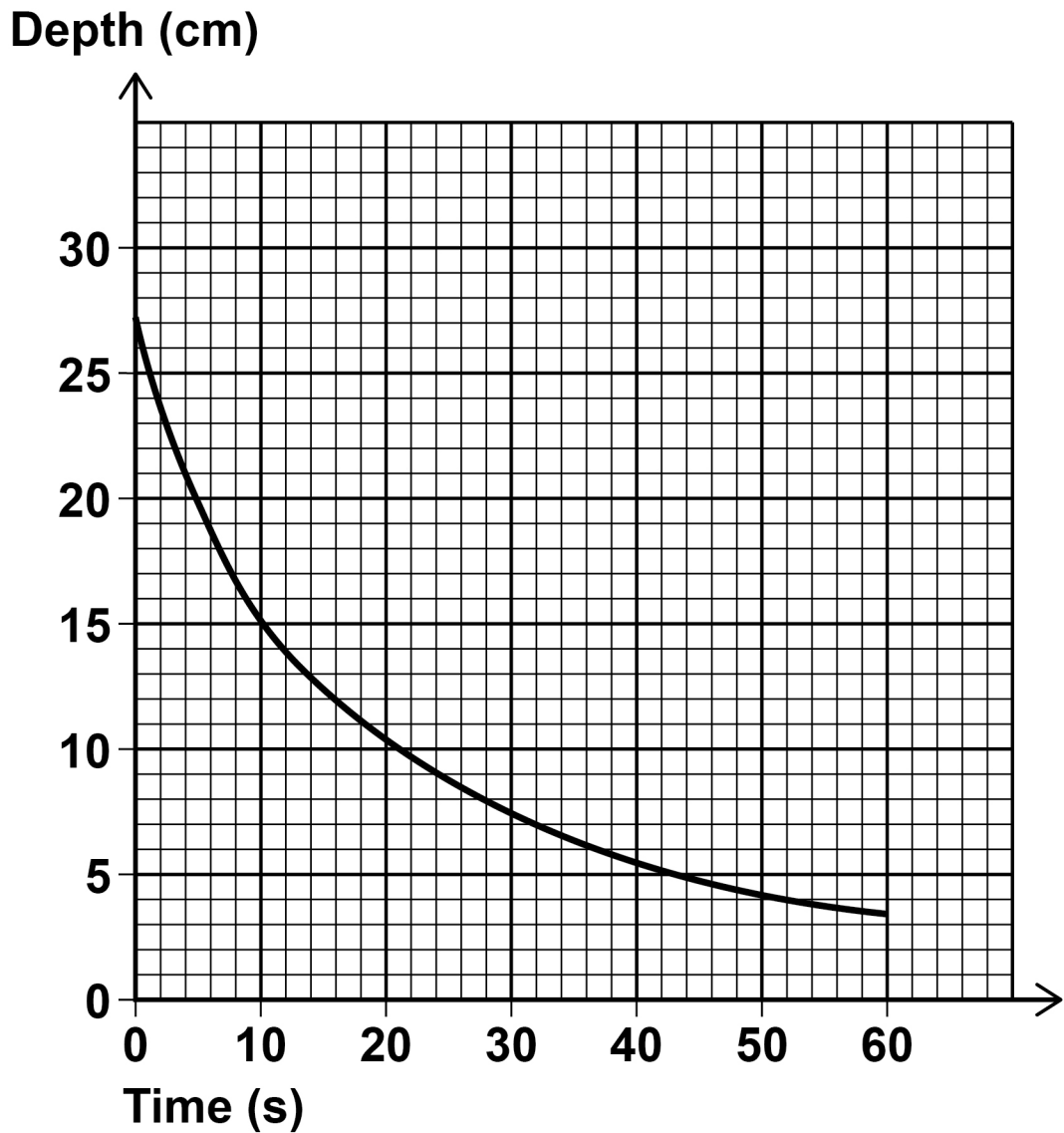

26 $a^2 - b^2 \equiv (a + b)(a - b)$

a and b are positive whole numbers with $a > b$

$a^2 - b^2$ is a PRIME number.

Why are a and b consecutive numbers?
[2 marks]

<hr/>
5



BLANK PAGE

[Turn over]



- 27 $VABCD$ is a square-based pyramid.
 The horizontal base $ABCD$ has side length 10 cm
 and centre M .
 Angle VMA is 90°
 Angle VAM is 68°

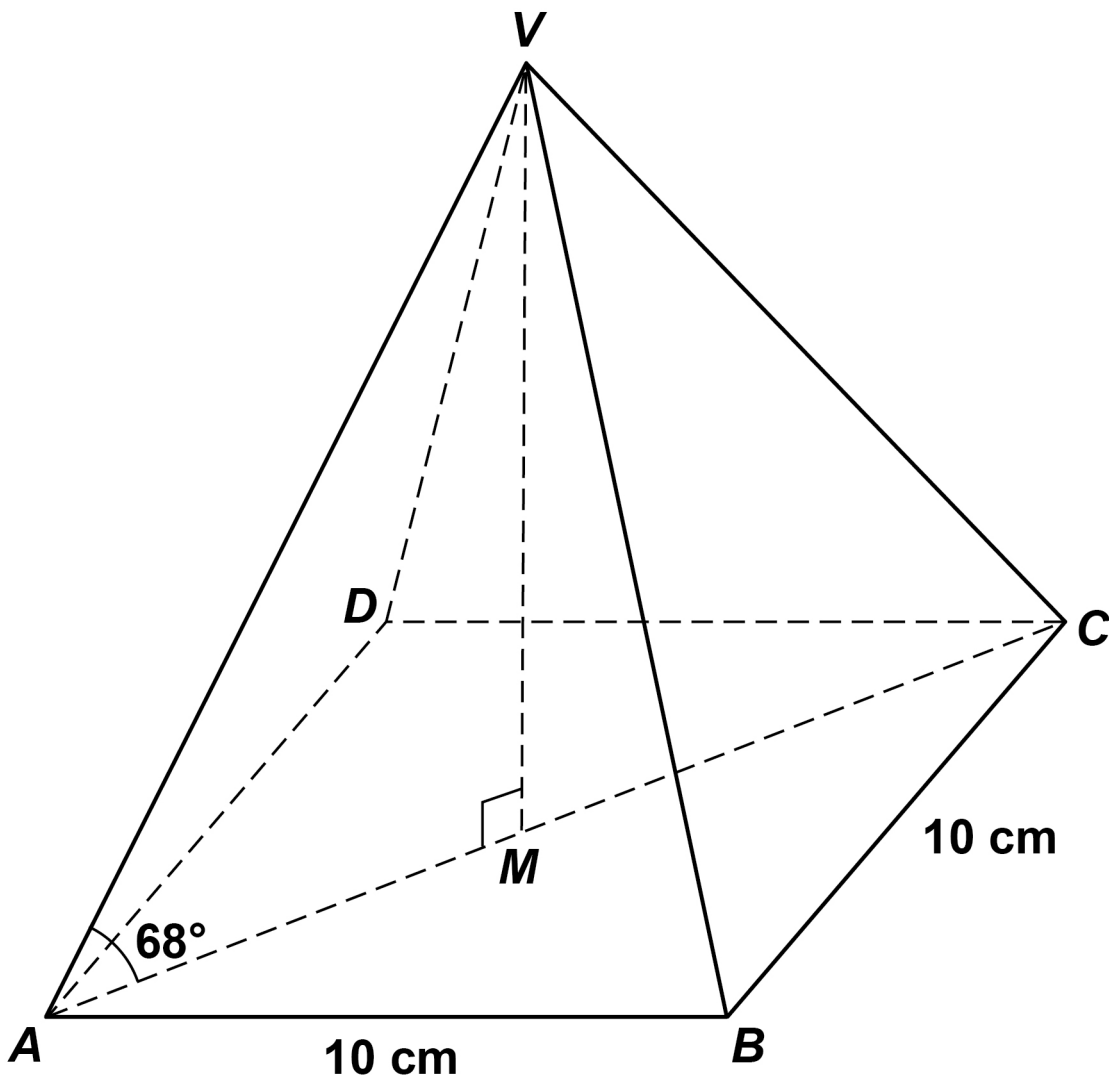

Volume of pyramid

$$= \frac{1}{3} \times \text{area of base} \times \text{perpendicular height}$$



- 29 Here is the graph of $y = f(x)$ where $f(x)$ is a quadratic function.

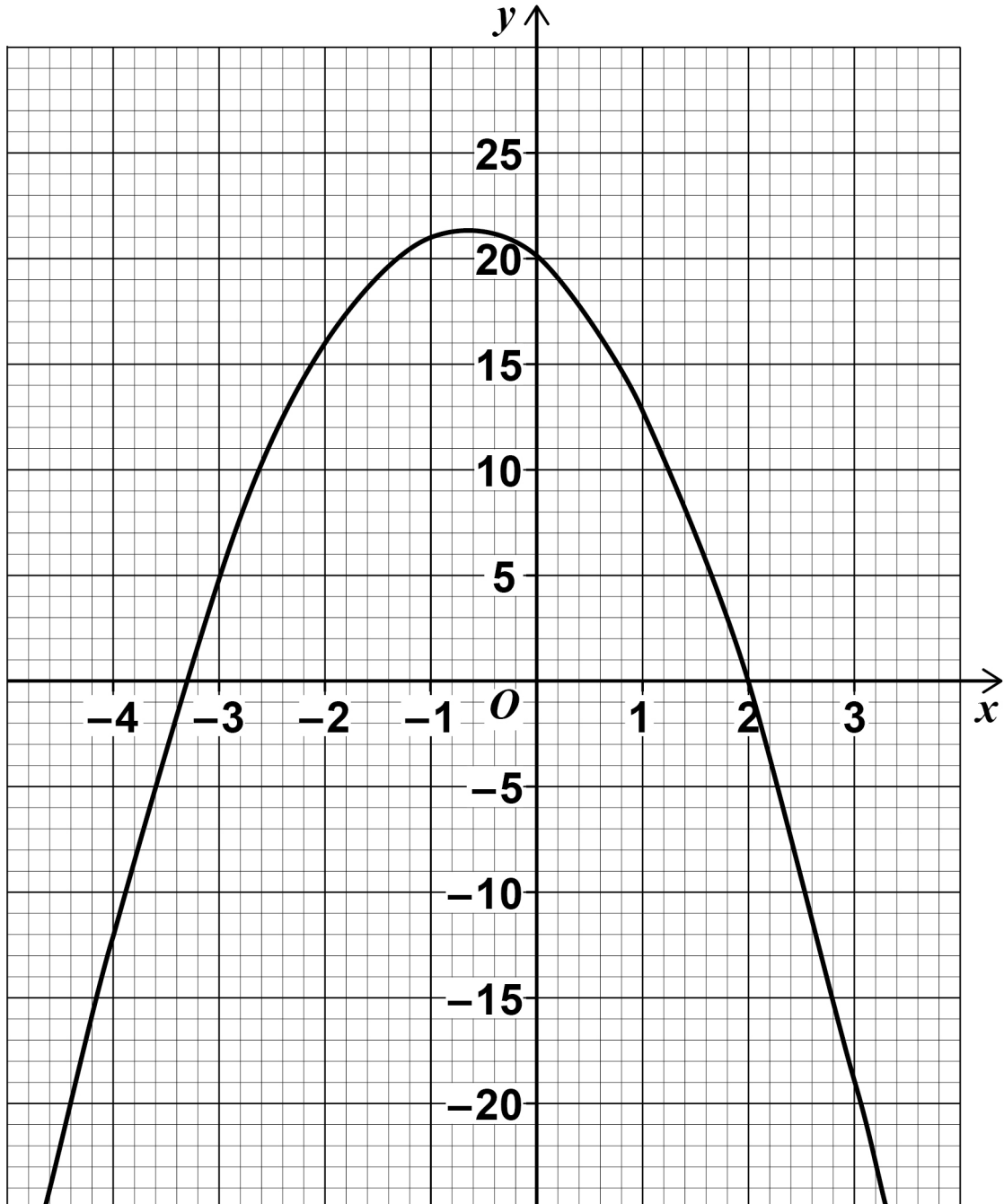

Write down all the INTEGER solutions of
 $f(x) \geq 0$ [2 marks]

Answer _____

7

[Turn over]



There are no questions printed on this page



There are no questions printed on this page

For Examiner's Use	
Pages	Mark
4-5	
6-9	
10-11	
12-13	
14-17	
18-20	
21-23	
24-26	
28-30	
32-34	
36-38	
39-41	
42	
TOTAL	

Copyright information

For confidentiality purposes, from the November 2015 examination series, acknowledgements of third party copyright material will be published in a separate booklet rather than including them on the examination paper or support materials. This booklet is published after each examination series and is available for free download from www.aqa.org.uk after the live examination series.

Permission to reproduce all copyright material has been applied for. In some cases, efforts to contact copyright-holders may have been unsuccessful and AQA will be happy to rectify any omissions of acknowledgements. If you have any queries please contact the Copyright Team, AQA, Stag Hill House, Guildford, GU2 7XJ.

Copyright © 2017 AQA and its licensors. All rights reserved.

IB/M/Nov17/RR/8300/3H/E5

