

AQA **Surname** _____**Other Names** _____**Centre Number** _____**Candidate Number** _____**Candidate Signature** _____**I declare this is my own work.****GCSE****COMBINED SCIENCE: TRILOGY****Higher Tier****Biology Paper 2H****H****8464/B/2H****Time allowed: 1 hour 15 minutes****At the top of the page, write your surname and other names, your centre number, your candidate number and add your signature.****[Turn over]**

For this paper you must have:

- **a ruler**
- **a scientific calculator.**

INSTRUCTIONS

- **Use black ink or black ball-point pen.**
- **Pencil should only be used for drawing.**
- **Answer ALL questions in the spaces provided.**
- **If you need extra space for your answer(s), use the lined pages at the end of this book. Write the question number against your answer(s).**
- **Do all rough work in this book. Cross through any work you do not want to be marked.**
- **In all calculations, show clearly how you work out your answer.**



INFORMATION

- **The maximum mark for this paper is 70.**
- **The marks for questions are shown in brackets.**
- **You are expected to use a calculator where appropriate.**
- **You are reminded of the need for good English and clear presentation in your answers.**

DO NOT TURN OVER UNTIL TOLD TO DO SO



0	1
---	---

FIGURE 1 shows glands in the human body.

FIGURE 1

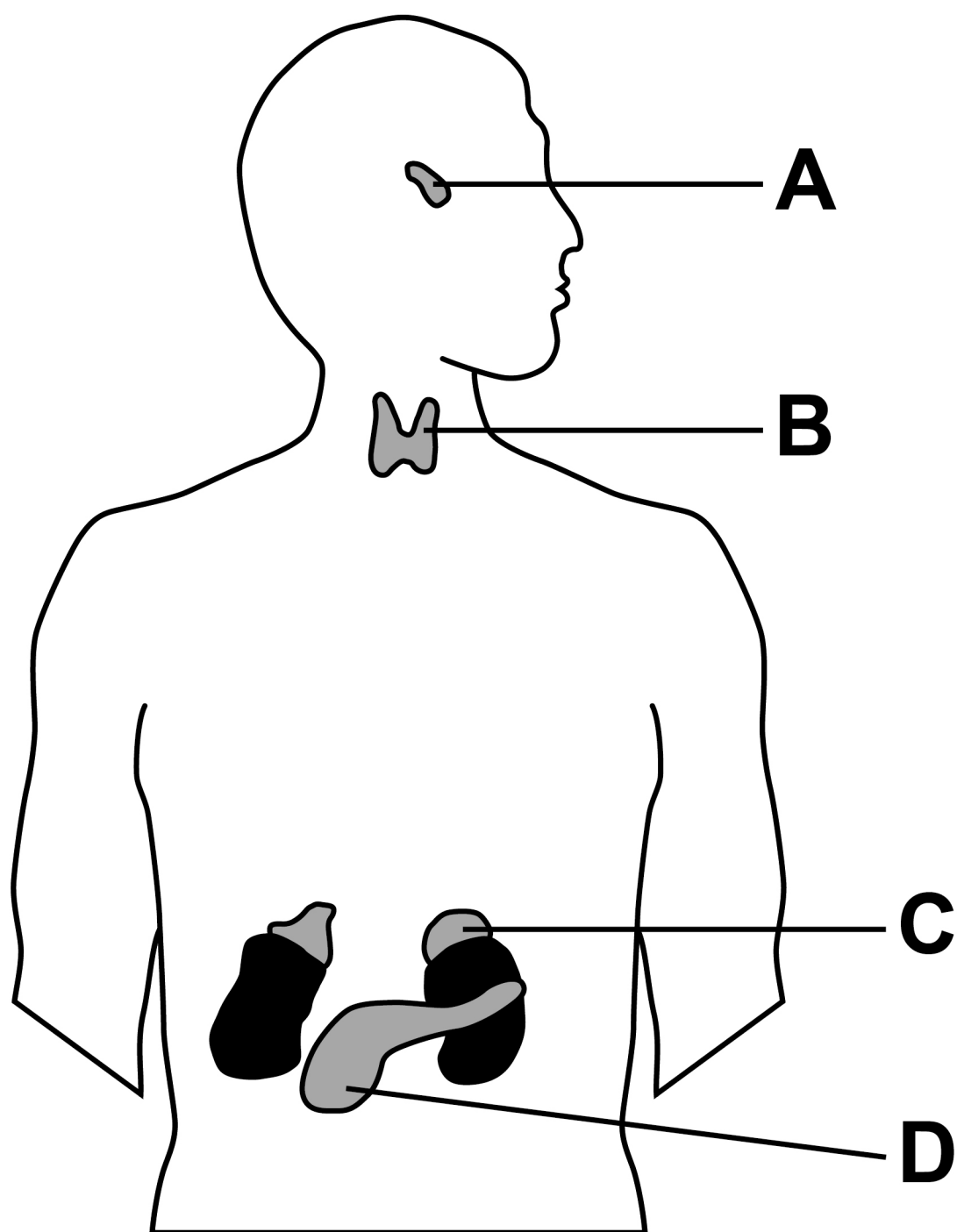

0 1 . 1

Which organ system includes the glands shown in FIGURE 1? [1 mark]

0 1 . 2

Which gland produces insulin? [1 mark]

Tick (✓) ONE box.

A

B

C

D

[Turn over]



REPEAT OF FIGURE 1

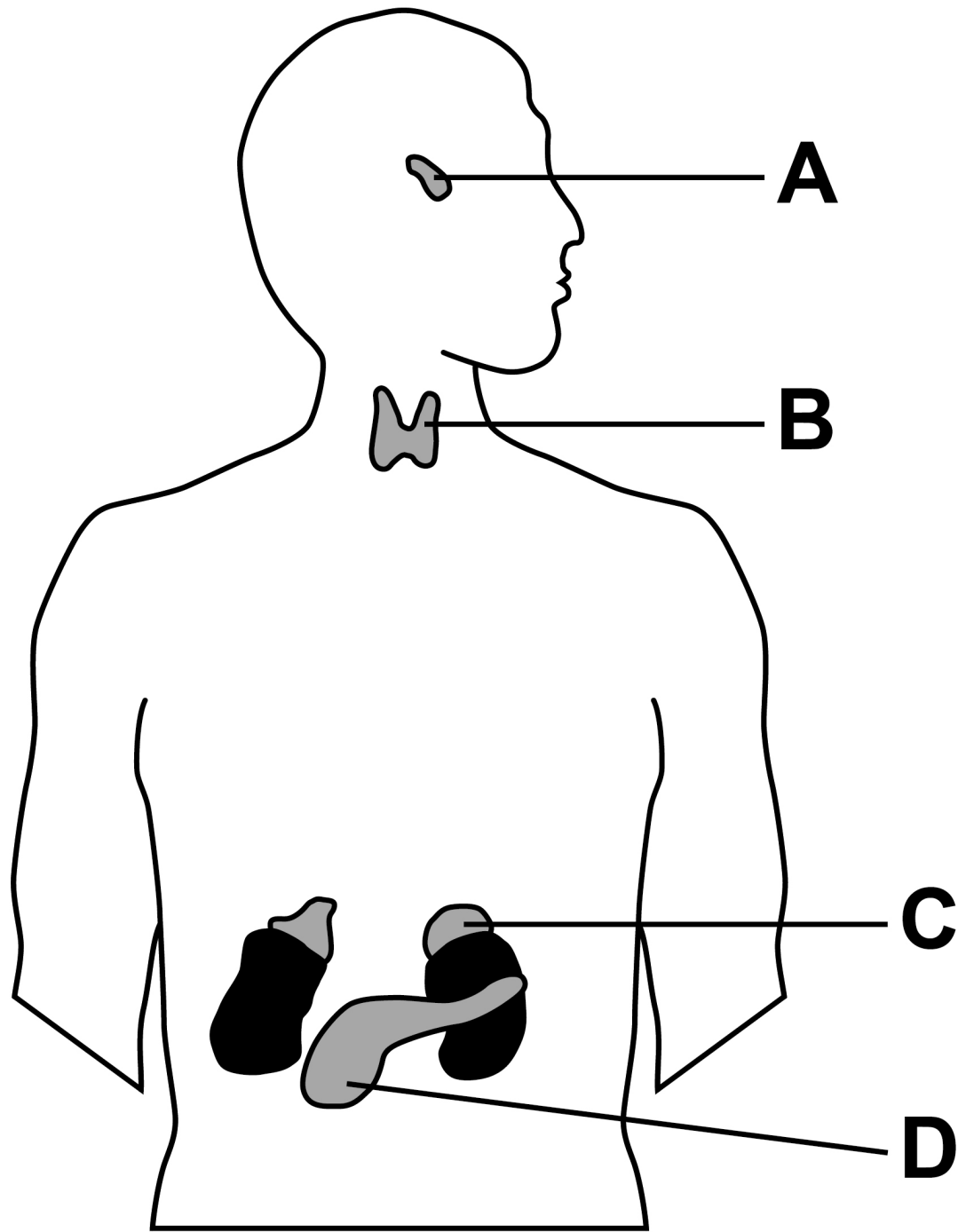

0 1 . 3

Which gland produces hormones that stimulate the other glands to produce hormones? [1 mark]

Tick (✓) ONE box.

A

B

C

D

[Turn over]

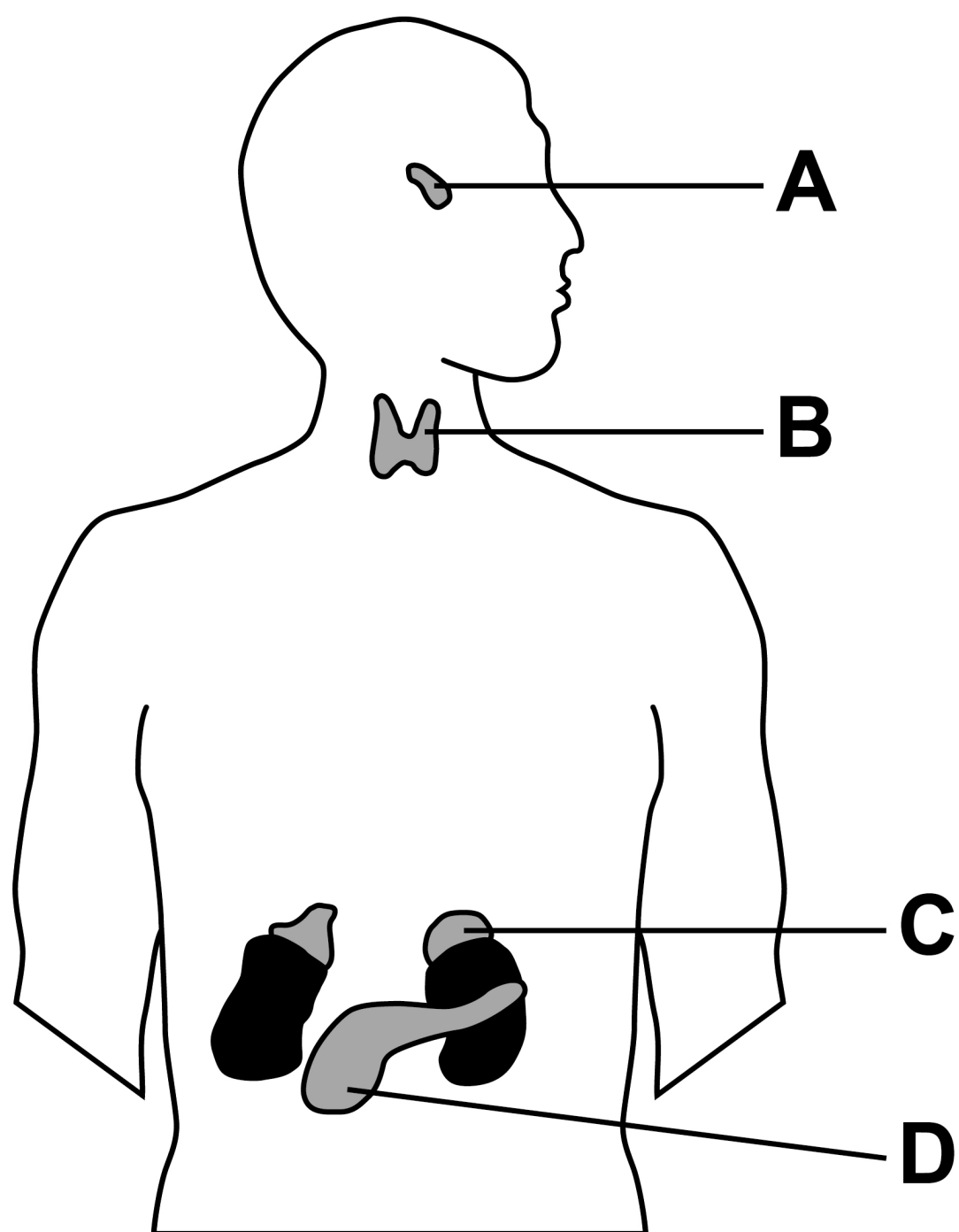

REPEAT OF FIGURE 1

0	1	.	4
---	---	---	---

How do hormones travel from one gland to another gland? [1 mark]



01.5

Name TWO glands involved in human reproduction.

Do NOT refer to glands shown on FIGURE 1 in your answer. [2 marks]

1 _____

2 _____

[Turn over]



01.6

Ovulation test kits can help women know when they are most fertile.

Ovulation test kits detect the increase in the hormone that stimulates ovulation.

Which hormone is detected by ovulation test kits? [1 mark]

Tick (✓) ONE box.

Follicle stimulating hormone (FSH)

Luteinising hormone (LH)

Oestrogen

Progesterone



BLANK PAGE

[Turn over]



01.7

A new contraceptive drug for men is being tested.

The drug:

- is given in one injection**
- stops sperm being able to fertilise eggs**
- is effective for up to 13 years.**

Evaluate the use of the new drug compared with existing contraceptive methods. [6 marks]



[Turn over]



1 3

13

02

FIGURE 2, on the opposite page, shows the money spent on conserving biodiversity in the UK by the government.

02.1

Describe the trends in the money spent on conserving biodiversity from 2005 to 2011.

Use data from FIGURE 2 in your answer. [2 marks]

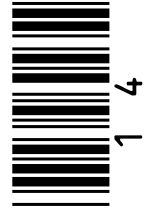
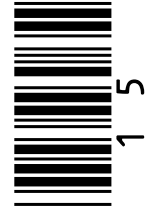
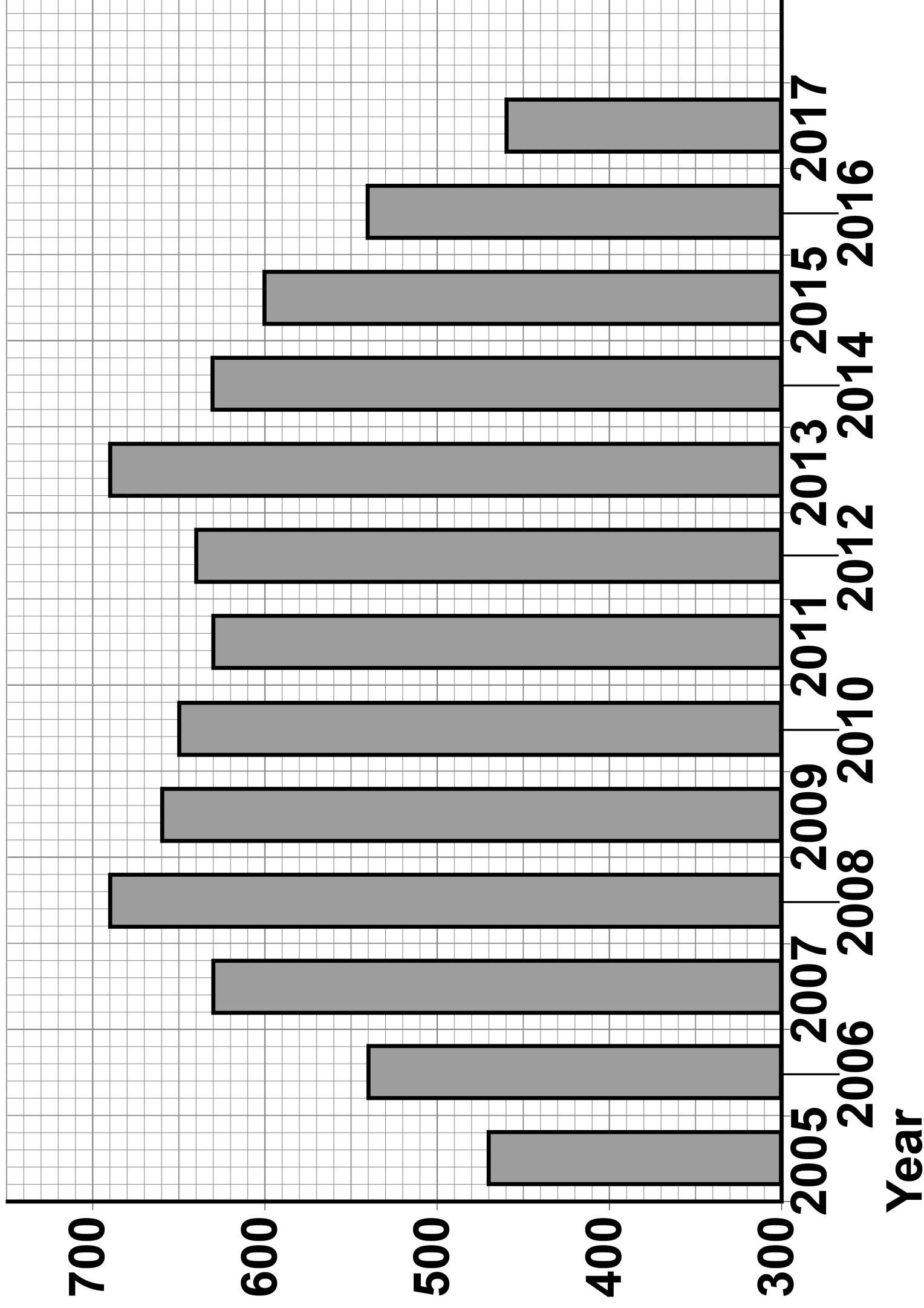

FIGURE 2

Money spent
in millions of pounds



0 2 . 2

Calculate the percentage decrease in the money spent on conserving biodiversity from 2013 to 2017.

Use the equation:

percentage decrease =

$$\frac{\text{change in money spent from 2013 to 2017}}{\text{money spent in 2013}} \times 100$$

16

Give your answer to 2 significant figures. [3 marks]



Percentage decrease (2 significant figures) =
_____ %

[Turn over]

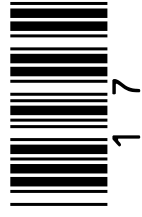

0 2 . 3

Conservation of peat bogs can help maintain biodiversity.

Give TWO uses of peat taken from peat bogs. [2 marks]

1 _____

2 _____

0 2 . 4

Describe TWO ways to INCREASE biodiversity in the UK.

Do NOT refer to money spent or to peat in your answer. [2 marks]

1 _____

2 _____

[Turn over]

9



0	3
---	---

A fossil was found in rocks. The rocks were formed from mud.

The fossil is of the fungus ‘Ourasphaira giraldae’.

0	3	.	1
---	---	---	---

**What is the genus of the fungus?
[1 mark]**



0	3	.	2
---	---	---	---

Why was the mud important during the formation of the fossil? [1 mark]

Tick (✓) ONE box.

The fungus completely decayed in the mud.

The mud stopped oxygen reaching the fungus.

There was water in the mud around the fungus.

[Turn over]



The estimated age of the fossil is in the range from 8.9×10^8 years old to 1.1×10^9 years old.

0 3 . 3

Calculate the size of the range of the estimated age of the fossil. [1 mark]

Size of range = _____ years



0	3	.	4
---	---	---	---

Humans did NOT exist when the fungus was alive.

Suggest ONE other reason why an accurate estimation of when this species of fungus existed is not known. [1 mark]

[Turn over]



Carl Woese developed the three-domain system of classification.

0 3 . 5

Fungi are NOT in the domain Archaea.

**Which domain are fungi classified in?
[1 mark]**



0	3	.	6
---	---	---	---

**Which TWO characteristics are features of organisms in the domain Archaea?
[2 marks]**

Tick (✓) TWO boxes.

Can only survive in light

Can survive in extreme environments

Cells contain chloroplasts

Cells do not have a cell wall

Cytoplasm contains DNA

[Turn over]



03.7

Carl Linnaeus lived in the 1700s.

Carl Linnaeus classified living things into groups depending on their appearance.

Give THREE types of evidence that are used NOW to classify living things.

Do NOT refer to appearance in your answer. [3 marks]

1 _____

2 _____

3 _____



BLANK PAGE

[Turn over]



0 4

FIGURE 3 shows one species of bird on a bird feeder.

FIGURE 3



The birds use their beaks to reach nuts inside the bird feeder.

FIGURE 4, on page 30, shows the mean beak length of this species of bird in the UK.

This species of bird often visits bird feeders.

[Turn over]

FIGURE 4

**Mean beak
length in mm**

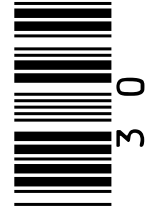
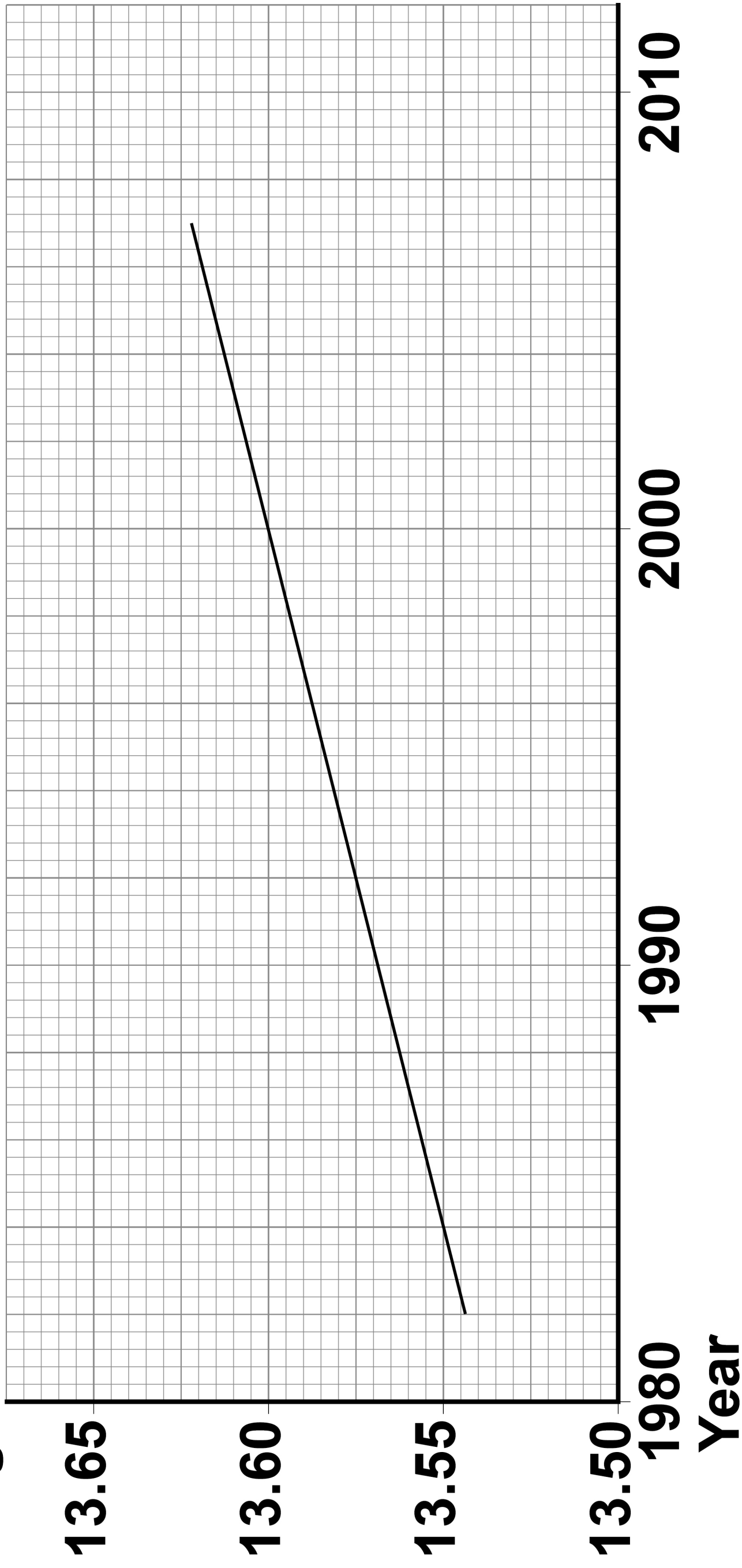

0 4 . 1

Determine the rate of change in beak length from 1984 to 2000.

Use FIGURE 4. [3 marks]

31

Rate of change = _____ mm/year

[Turn over]

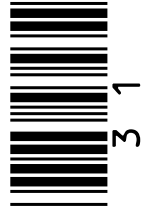

REPEAT OF FIGURE 4

Mean beak
length in mm

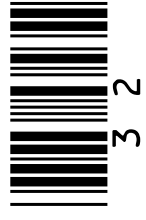
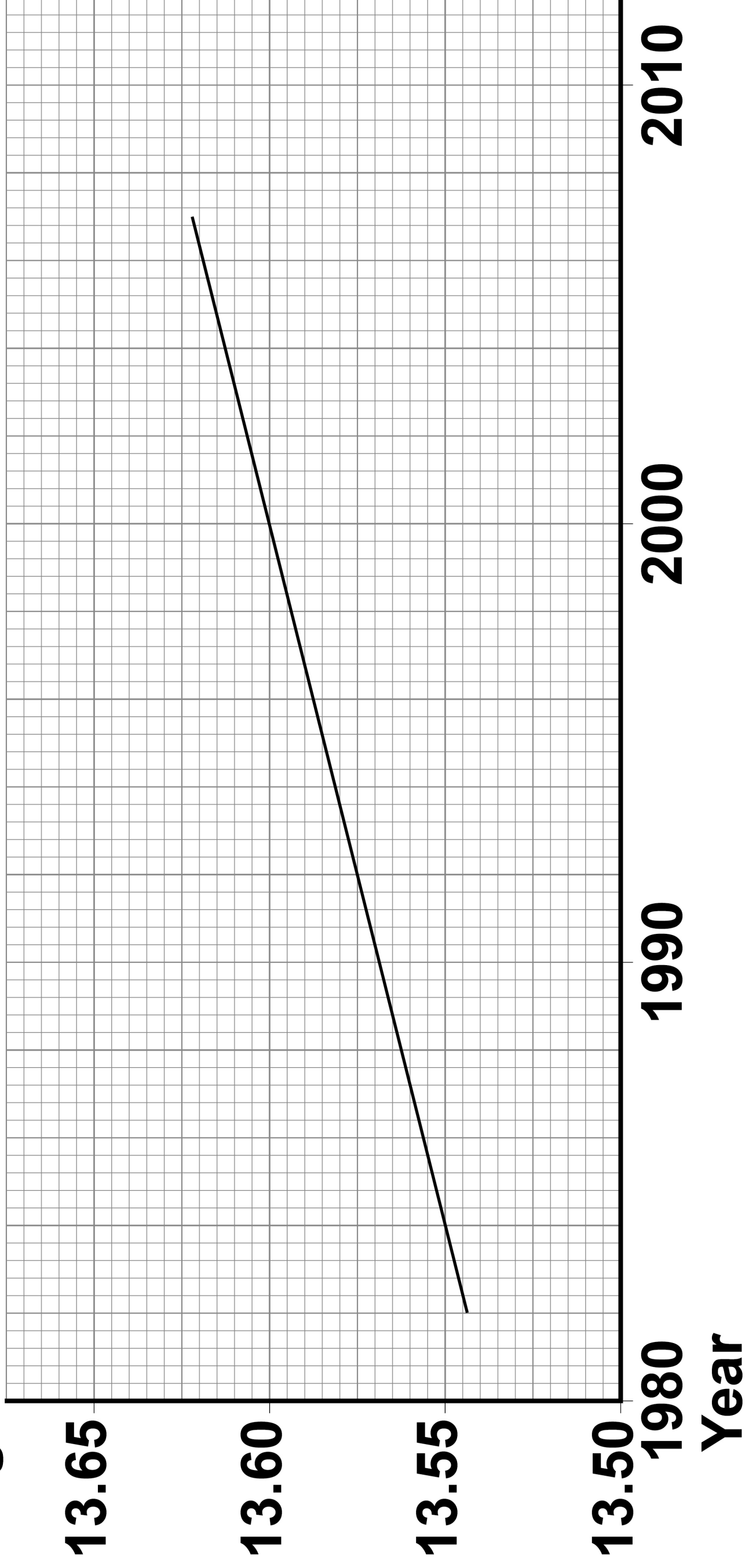

04.2

Explain the process of evolution that could cause the trend in FIGURE 4. [6 marks]

33

[Turn over]

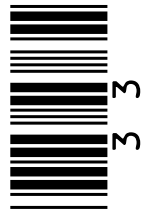

Vertical lines for writing.



BLANK PAGE

[Turn over]

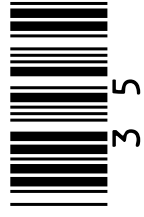

0	4	.	3
---	---	---	---

Birds of this species:

- live for about 3 years
- produce up to 24 eggs every year.

Explain why evolution is easier to study in this species of bird than in humans.

[3 marks]



0 **4** . **4**

Birds of this species are found in different parts of the world.

**Describe evidence that would show two individual birds are the same species.
[3 marks]**

[Turn over]



0	5
---	---

Caffeine is a drug that decreases reaction time.

A group of sixteen students investigated the effect of caffeine on reaction time.

The students were all 15-year-old girls.

The group was divided into 8 pairs of students.



This is the method used.

- 1. Student A starts two stopwatches at the same time.**
- 2. Student A then gives one of the stopwatches to Student B.**
- 3. Student A says “stop” at the same time as stopping her stopwatch. Student B stops her stopwatch as quickly as possible after Student A says “stop”.**
- 4. The difference in time shown on the two stopwatches is recorded. This is the reaction time of Student B.**
- 5. Student B drinks a caffeinated drink.**
- 6. The students wait 15 minutes and then repeat steps 1 to 4.**

[Turn over]



05.1

Suggest ONE control variable the students should have used in the investigation.

Do NOT refer to age or sex in your answer. [1 mark]

05.2

Suggest TWO sources of random error when using this method to measure a person's reaction time. [2 marks]

1 _____

2 _____

[Turn over]



TABLE 1 shows the results.

TABLE 1

Student pair	Decrease in reaction time after drinking the caffeinated drink in seconds
1	0.039
2	0.021
3	0.027
4	0.041
5	0.022
6	0.036
7	0.024
8	0.097



0 5 . 3

Why can a mode NOT be determined for the data in TABLE 1? [1 mark]

0 5 . 4

The students decided the result from pair 8 was anomalous.

The students calculated that the mean decrease in reaction time was 0.030 seconds.

Describe how the students calculated the mean decrease in reaction time. [1 mark]



0 5 . 5

Caffeine causes the release of adrenaline.

Adrenaline affects heart rate.

Explain how the effect of adrenaline on heart rate might cause reaction time to decrease. [4 marks]

[Turn over]



Adenosine is a different chemical made by the body.

Adenosine binds to receptors on relay neurones.

Adenosine decreases the number of impulses in relay neurones.

FIGURE 5, on the opposite page, shows how caffeine binds to adenosine receptors on a relay neurone.

When caffeine binds to adenosine receptors it blocks the receptor so adenosine cannot bind.

0 5 . 6

Label X shows the gap between the sensory neurone and the relay neurone.

**What is the name of the gap labelled X?
[1 mark]**



FIGURE 5

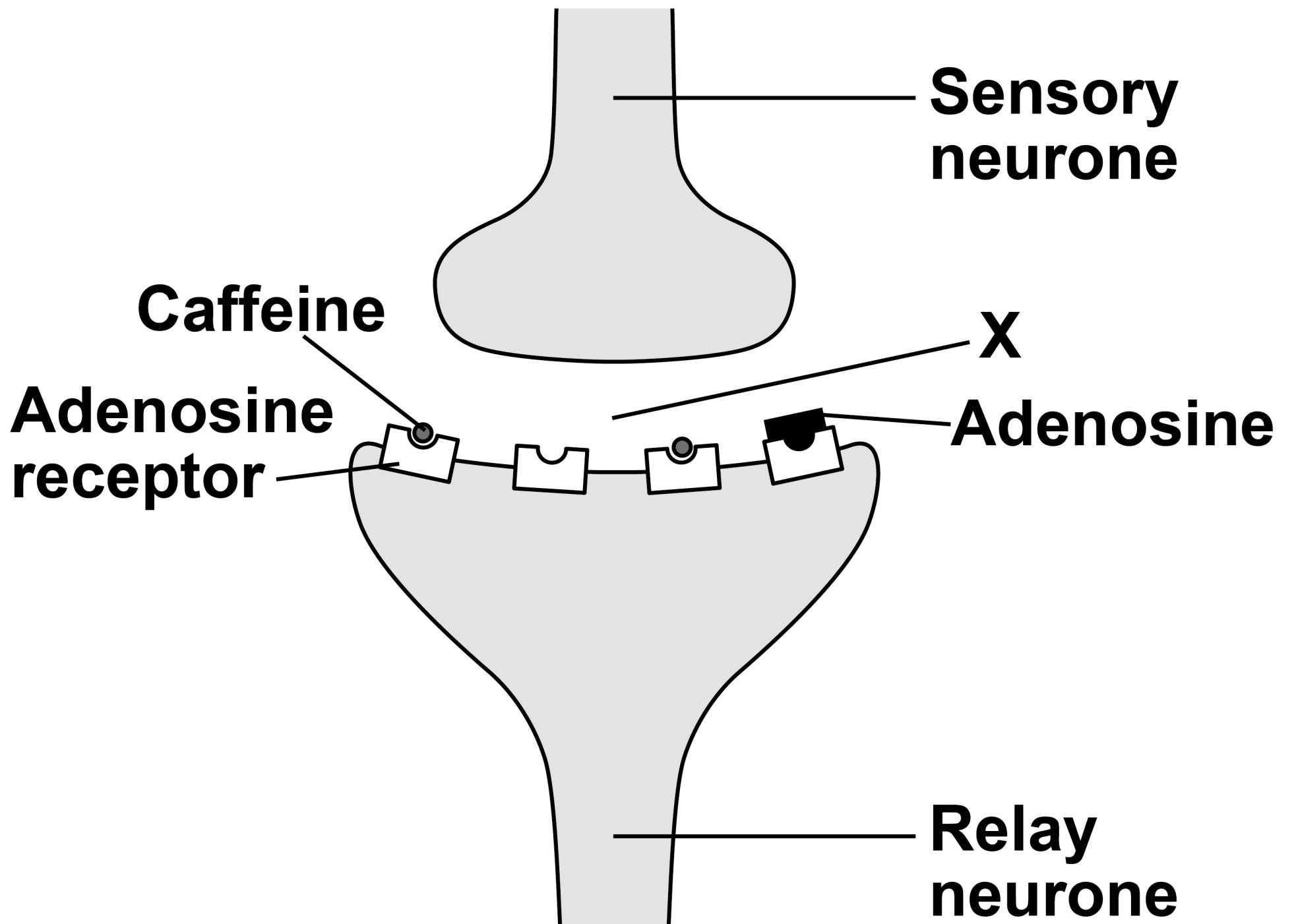

[Turn over]

0	5	.	7
---	---	---	---

Suggest why reaction time decreases when caffeine binds to adenosine receptors. [2 marks]

12



0	6
---	---

This question is about genetic disorders.

0	6	.	1
---	---	---	---

Some people are heterozygous for a genetic disorder.

Define the term 'heterozygous'. [1 mark]

[Turn over]



06.2

FIGURE 6 shows the inheritance of a genetic disorder in a family.

FIGURE 6

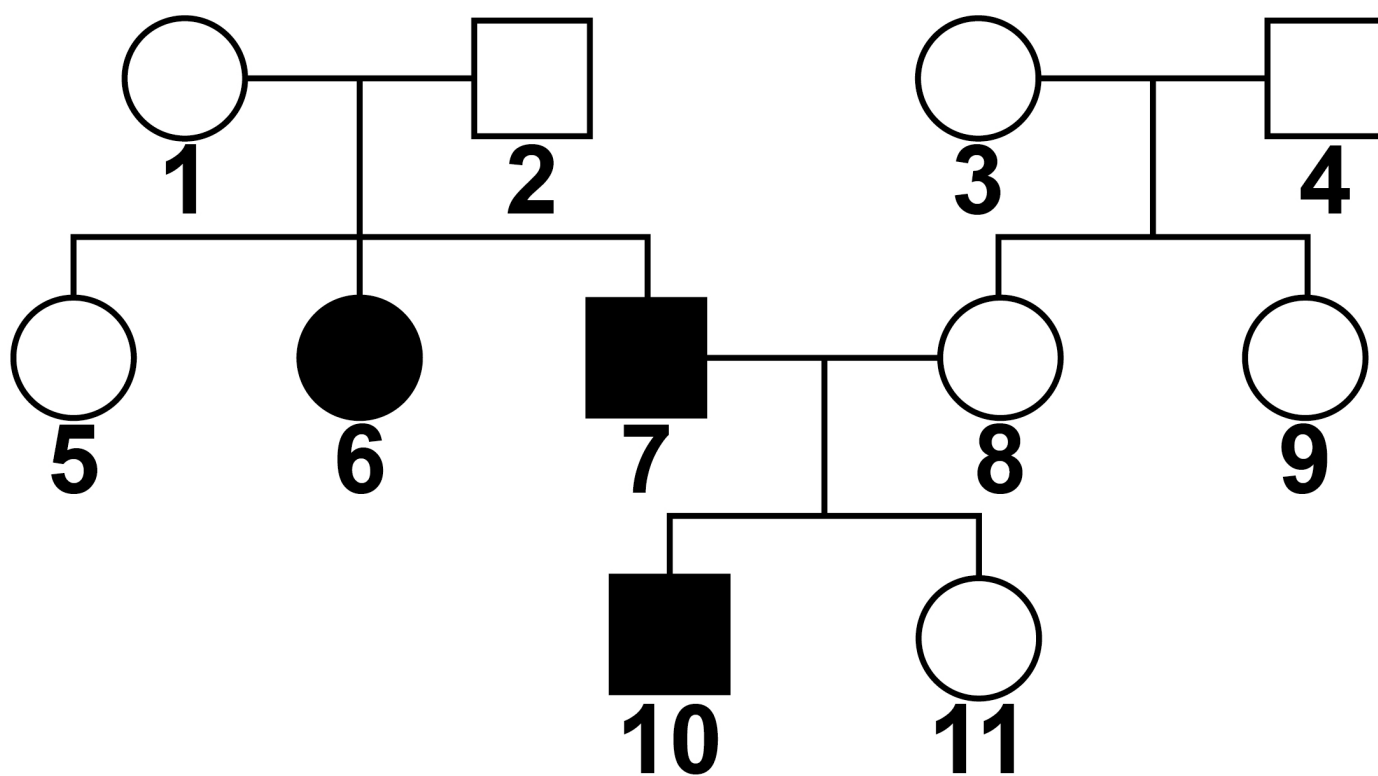

KEY

- Female who does NOT have the disorder
- Male who does NOT have the disorder
- Female who has the disorder
- Male who has the disorder



BLANK PAGE

[Turn over]



Person 7 and person 8 plan to have another child.

Determine the probability that the child will be a MALE who has the disorder.

You should:

- **draw a Punnett square diagram**
- **identify the genotype of person 7 and the genotype of person 8**
- **identify the phenotype of each offspring genotype**
- **use the symbols:**
 - H = dominant allele**
 - h = recessive allele**

[6 marks]



Probability of having a male child with the disorder = _____

[Turn over]



06.3

Polydactyly is a different inherited disorder.

Two parents do NOT have any alleles for polydactyly in their ordinary body cells.

These parents produced a child with polydactyly.

Explain how polydactyly suddenly occurred in this family. [4 marks]

END OF QUESTIONS

11



Additional page, if required.

Write the question numbers in the left-hand margin.



BLANK PAGE

For Examiner's Use	
Question	Mark
1	
2	
3	
4	
5	
6	
TOTAL	

Copyright information

For confidentiality purposes, all acknowledgements of third-party copyright material are published in a separate booklet. This booklet is published after each live examination series and is available for free download from www.aqa.org.uk.

Permission to reproduce all copyright material has been applied for. In some cases, efforts to contact copyright-holders may have been unsuccessful and AQA will be happy to rectify any omissions of acknowledgements. If you have any queries please contact the Copyright Team.

Copyright © 2021 AQA and its licensors. All rights reserved.

IB/M/CH/Jun21/8464/B/2H/E1



5 8



2 1 6 G 8 4 6 4 / B / 2 H