



Surname _____

Other Names _____

Centre Number _____

Candidate Number _____

Candidate Signature _____

I declare this is my own work.

GCSE

COMBINED SCIENCE: TRILOGY

Higher Tier

Physics Paper 1H

8464/P/1H

H

Time allowed: 1 hour 15 minutes

At the top of the page, write your surname and other names, your centre number, your candidate number and add your signature.

[Turn over]



J U N 2 1 8 4 6 4 P 1 H 0 1

For this paper you must have:

- **a ruler**
- **a scientific calculator**
- **the Physics Equations Sheet (enclosed).**

INSTRUCTIONS

- **Use black ink or black ball-point pen.**
- **Pencil should be used for drawing.**
- **Answer ALL questions in the spaces provided.**
- **If you need extra space for your answer(s), use the lined pages at the end of this book. Write the question number against your answer(s).**
- **Do all rough work in this book. Cross through any work you do not want to be marked.**



- **In all calculations, show clearly how you work out your answer.**

INFORMATION

- **The maximum mark for this paper is 70.**
- **The marks for questions are shown in brackets.**
- **You are expected to use a calculator where appropriate.**
- **You are reminded of the need for good English and clear presentation in your answers.**

DO NOT TURN OVER UNTIL TOLD TO DO SO



0 1

FIGURE 1 shows a mobile phone with its battery removed.

FIGURE 1

Mobile phone



Battery

A student measured the potential difference across the battery and then put the battery into the phone.

0 1 . 1

What is the equation linking current (I), potential difference (V) and resistance (R)? [1 mark]

Tick (✓) ONE box.

$$I = V R$$

$$R = I V$$

$$V = I R$$

$$V = I^2 R$$

[Turn over]



01.2

The current in the electronic circuit in the mobile phone was 0.12 A.

The potential difference across the battery was 3.9 V.

Calculate the resistance of the electronic circuit in the mobile phone. [3 marks]

Resistance = _____ Ω



0	1	.	3
---	---	---	---

Write down the equation which links energy (E), power (P) and time (t).
[1 mark]

[Turn over]



0 1 . 4

The battery was fully charged when it was put into the mobile phone.

The battery discharged when the mobile phone was switched on.

The average power output of the battery as it discharged was 0.46 watts.

The time taken to fully discharge the battery was 2500 minutes.

Calculate the energy transferred by the battery. [3 marks]

Energy transferred = _____ J



BLANK PAGE

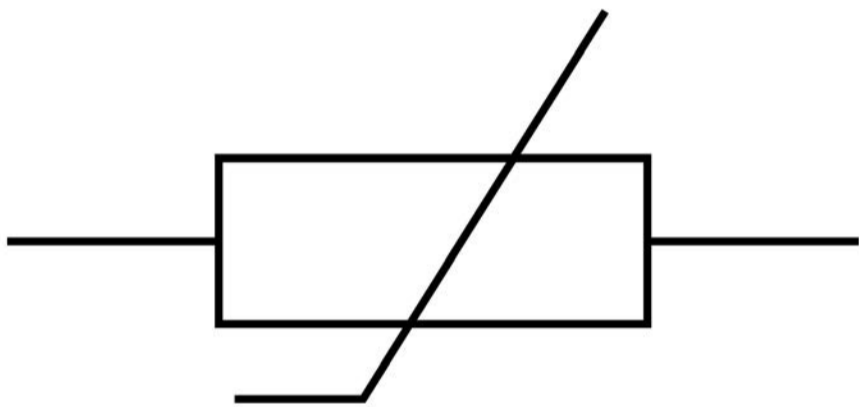
[Turn over]



The mobile phone includes a sensor to monitor the temperature of the battery.

FIGURE 2 shows the circuit symbol for a component used in the sensor.

FIGURE 2



0 1 . 5

What component does the circuit symbol shown in FIGURE 2 represent? [1 mark]

0 1 . 6

The temperature of the component in FIGURE 2 increases.

The potential difference across the component remains constant.

Explain what happens to the current in the component. [2 marks]

[Turn over]

<hr/>
11



0	2
---	---

A radioactive source emits alpha, beta and gamma radiation.

0	2	.	1
---	---	---	---

An alpha particle is the same as a helium nucleus.

How many times bigger is the radius of a helium atom than the radius of an alpha particle? [1 mark]

Tick (✓) ONE box.

Less than 100 times bigger

Exactly 5000 times bigger

More than 10 000 times bigger



0	2	.	2
---	---	---	---

Alpha particles can ionise atoms in the air.

What happens to an atom when it is ionised by an alpha particle? [2 marks]

Tick (✓) TWO boxes.

A neutron in the atom becomes a proton.

The atom becomes a positive ion.

The atom gains a neutron.

The atom gains a proton.

The atom loses an electron.

[Turn over]



0 2 . 3

A spark detector is a device that can be used to detect alpha radiation.

A spark detector works by alpha particles ionising atoms in the air near a wire mesh.

A large potential difference creates a spark when the air near the wire mesh is ionised.

Suggest why a spark detector CANNOT detect beta radiation. [1 mark]



02.4

A teacher wants to demonstrate that the radioactive source emits alpha, beta and gamma radiation.

FIGURE 3, on page 16, shows the equipment the teacher has.

[Turn over]

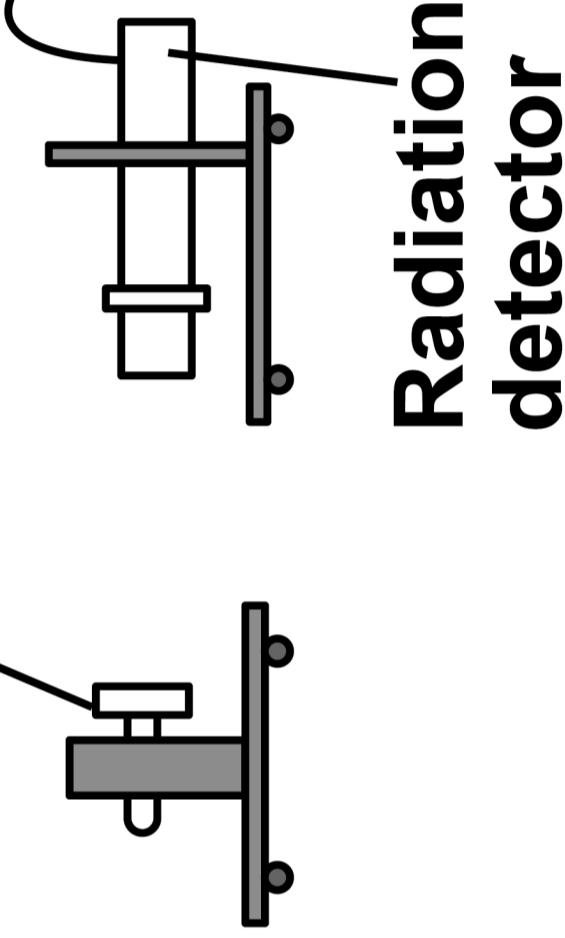


FIGURE 3

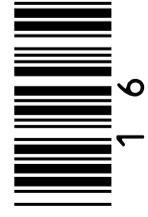
3 mm thick aluminium sheet

A thin sheet of paper

Radioactive source in a holder



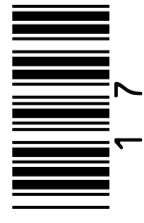
Count rate meter



Describe a method the teacher could use. [6 marks]

17

[Turn over]





BLANK PAGE

[Turn over]



03

FIGURE 4 shows a sailing boat crossing an ocean.

FIGURE 4



There is a wind turbine on the boat.



0	3	.	1
---	---	---	---

The wind turbine generates electricity to charge a battery on the boat.

Name one OTHER renewable energy resource that could be used on the boat to generate electricity. [1 mark]

[Turn over]



03.2

The boat also has a generator that burns a fossil fuel.

The battery can be charged by either the wind turbine or the generator.

**Give TWO reasons why this is useful.
[2 marks]**

1 _____

2 _____



03.3

**Explain ONE environmental impact of using fossil fuels to generate electricity.
[2 marks]**

[Turn over]



0	3	.	4
---	---	---	---

The kinetic energy of the boat is 81 kJ.

mass of boat = 8000 kg

Calculate the speed of the boat. [4 marks]

Speed = _____ m/s



03.5

As the boat passes over a wave, the gravitational potential energy of the boat increases by 19 600 J.

mass of boat = 8000 kg

gravitational field strength = 9.8 N/kg

Calculate the change in height of the centre of mass of the boat as it passes over the wave. [3 marks]

Change in height = _____ m

[Turn over]



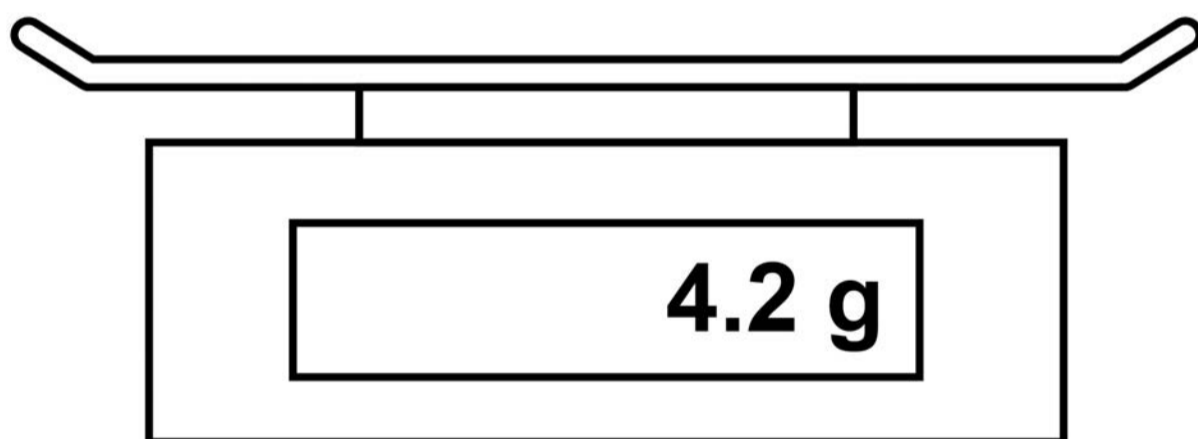
0	4
---	---

A student determined the density of a cube made of bronze.

The student used a balance to measure the mass of the bronze cube.

FIGURE 5 shows the balance before the cube was added.

FIGURE 5



0	4	.	1
---	---	---	---

What type of error is shown on the balance? [1 mark]

0	4	.	2
---	---	---	---

How could the student get a correct value for the mass of the cube from the balance? [1 mark]

[Turn over]



04.3

The student measured the length of the bronze cube using Vernier callipers and then using a micrometer.

TABLE 1 shows the results.

TABLE 1

Equipment	Length in mm
Vernier callipers	20.1
Micrometer	20.14

Complete the sentence. [1 mark]

The results in TABLE 1 show that the Vernier callipers and the micrometer have a different _____ .

The student wanted to determine the density of a bronze coin.

The student had several identical coins.

The volume of each coin was very small.

[Turn over]

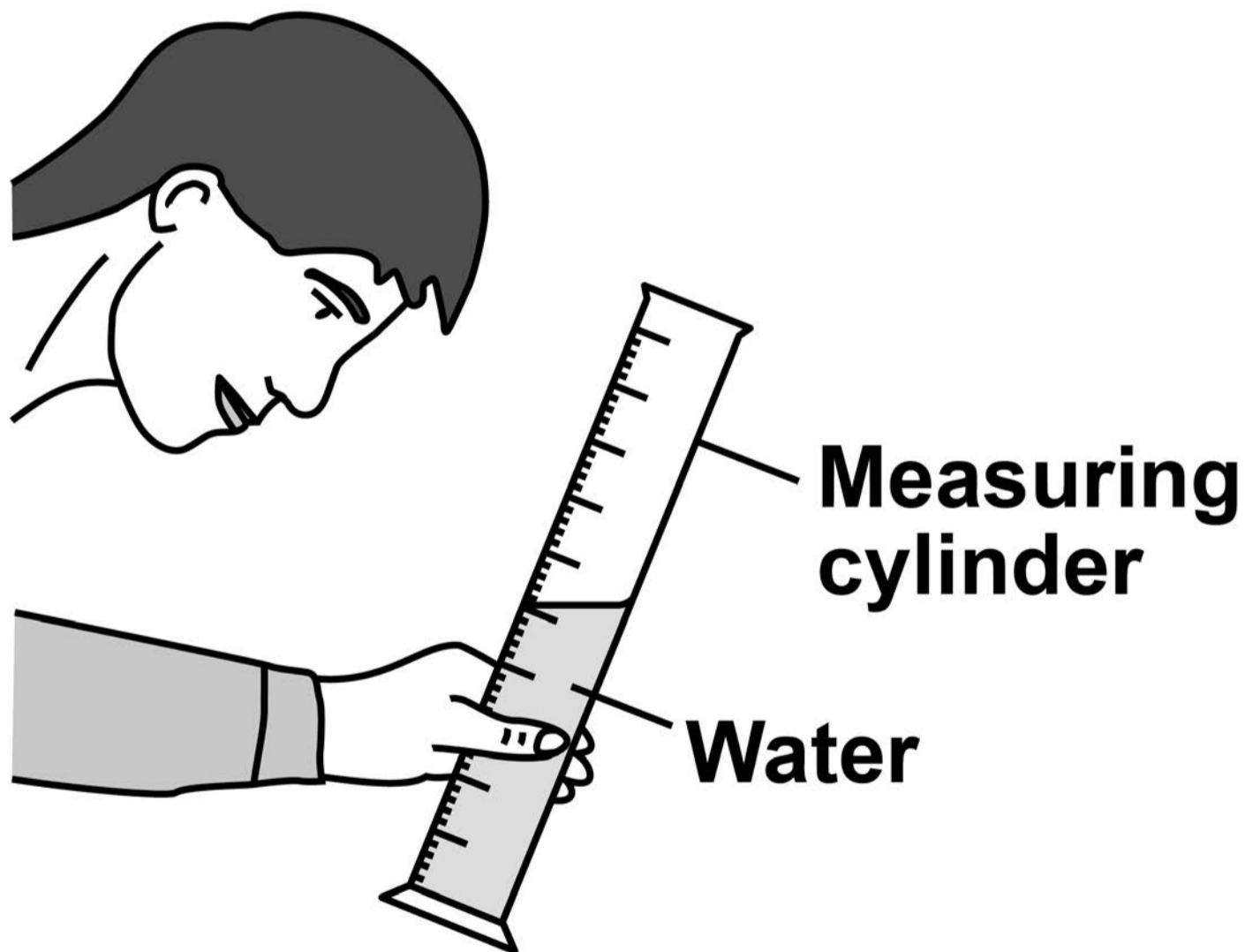


0	4	.	4
---	---	---	---

The student added water to a measuring cylinder.

FIGURE 6 shows the student reading the volume of water in the measuring cylinder.

FIGURE 6



Give TWO changes the student should make to increase the accuracy of the volume measurement. [2 marks]

1 _____

2 _____

[Turn over]



0	4	.	5
---	---	---	---

Describe how the student could use a displacement method to determine an accurate value for the volume of a single coin. [3 marks]



0 4 . 6

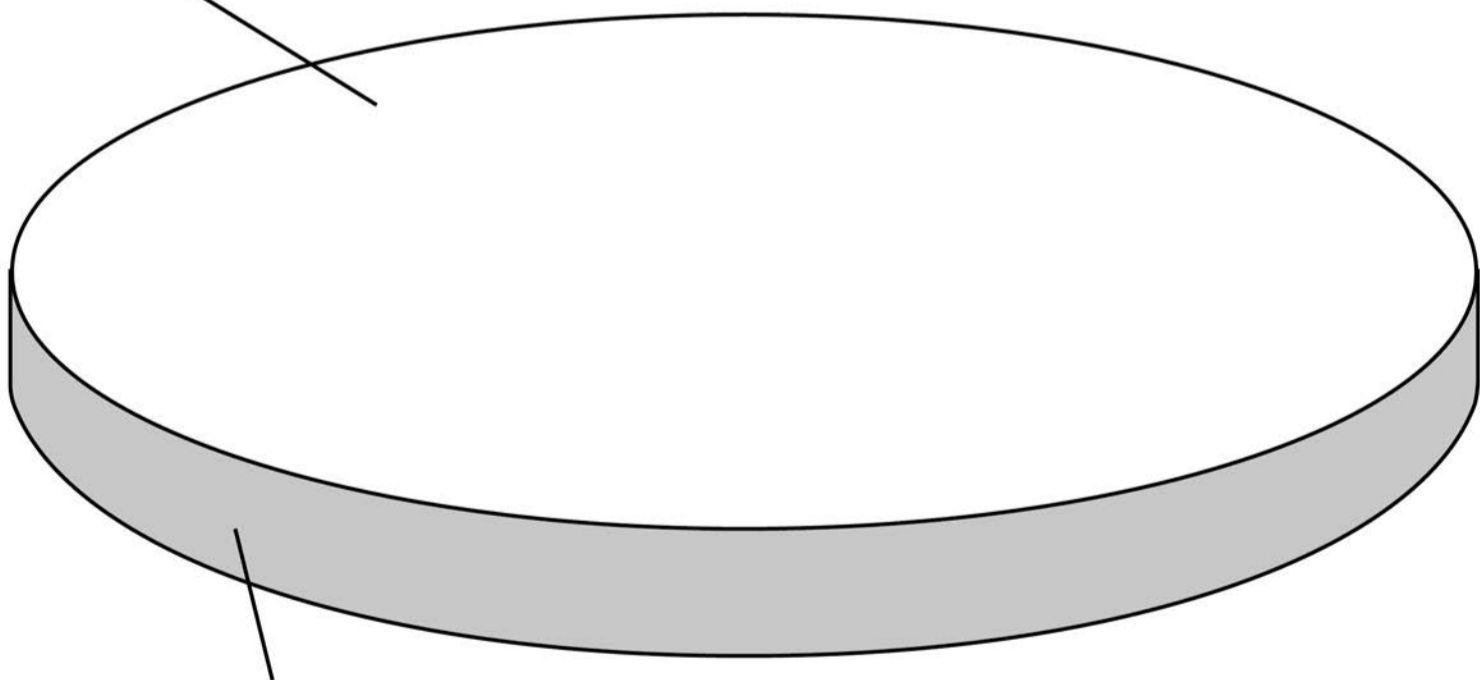
Old penny coins were made from a disc of bronze.

New penny coins are made from a disc of a different metal.

FIGURE 7 shows a disc of metal.

FIGURE 7

**Cross sectional
area**



Thickness

[Turn over]



TABLE 2 shows information about the discs used to make each coin.

TABLE 2

Disc	Mass in g	Density in g/cm³	Thickness in cm
Old penny	3.6	8.9	0.16
New penny	3.6	X	0.17

The discs used to make the old and the new coins have the SAME cross-sectional area.

Calculate value X in TABLE 2.

Give your answer to 2 significant figures.



The volume of a disc can be calculated using the equation:

**volume of a disc =
cross-sectional area x thickness**

[5 marks]

[Turn over]



Density (2 significant figures) =
_____ **g/cm³**

13



0	5
---	---

A TENS machine uses an electrical current to relieve pain.

FIGURE 8, on page 38, shows the electrodes of a TENS machine connected across an ankle.

[Turn over]



FIGURE 8

Electrodes



**TENS
machine**



0 5 . 1

The maximum power of the TENS machine is 240 mW.

The potential difference across the battery in the TENS machine is 2.5 V.

Calculate the maximum current from the battery. [4 marks]

Maximum current = _____ A

[Turn over]

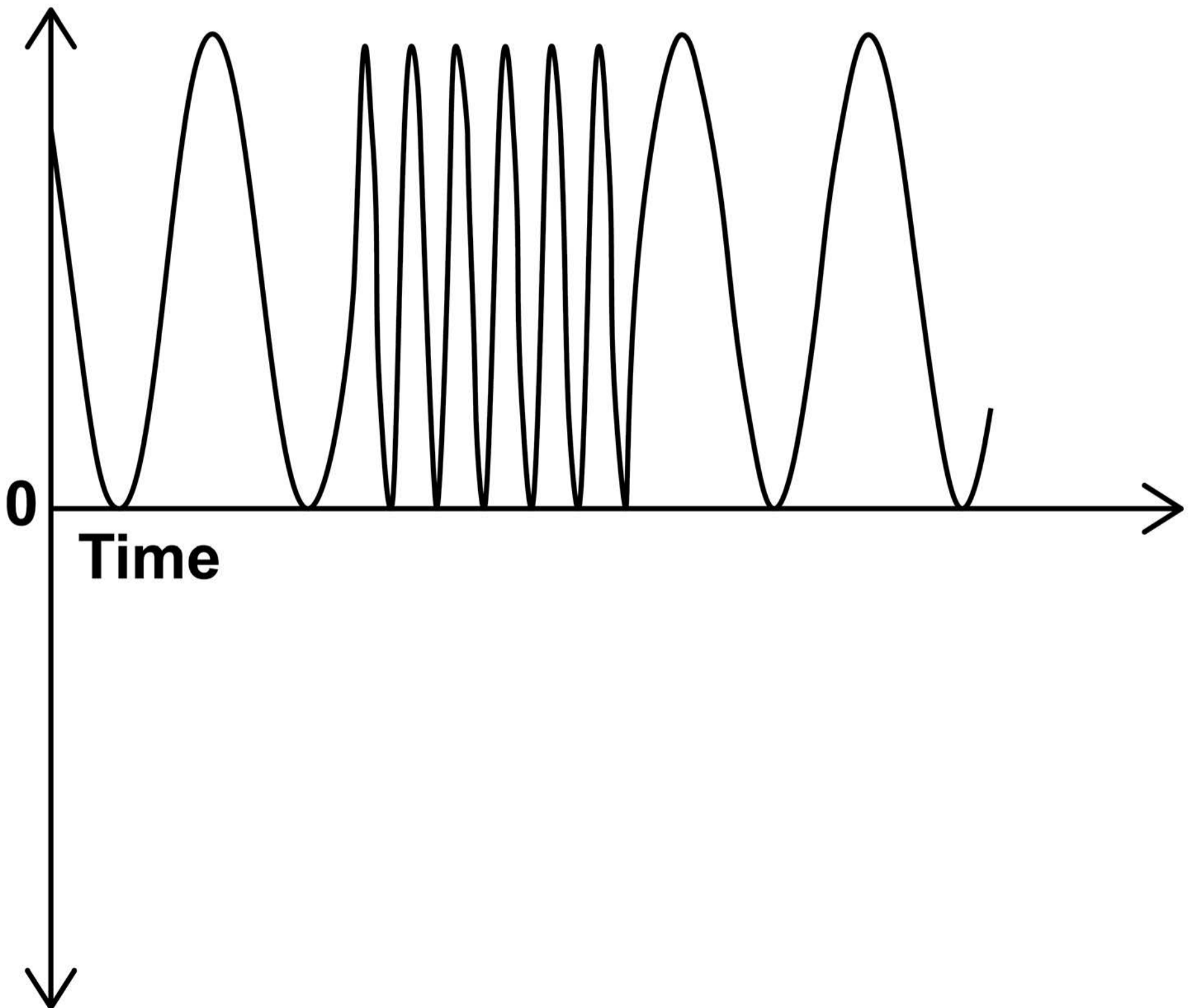


05.2

FIGURE 9 is a sketch graph showing how the potential difference across the electrodes varies with time.

FIGURE 9

**Potential
difference**



A student concluded that there was an alternating potential difference across the electrodes.

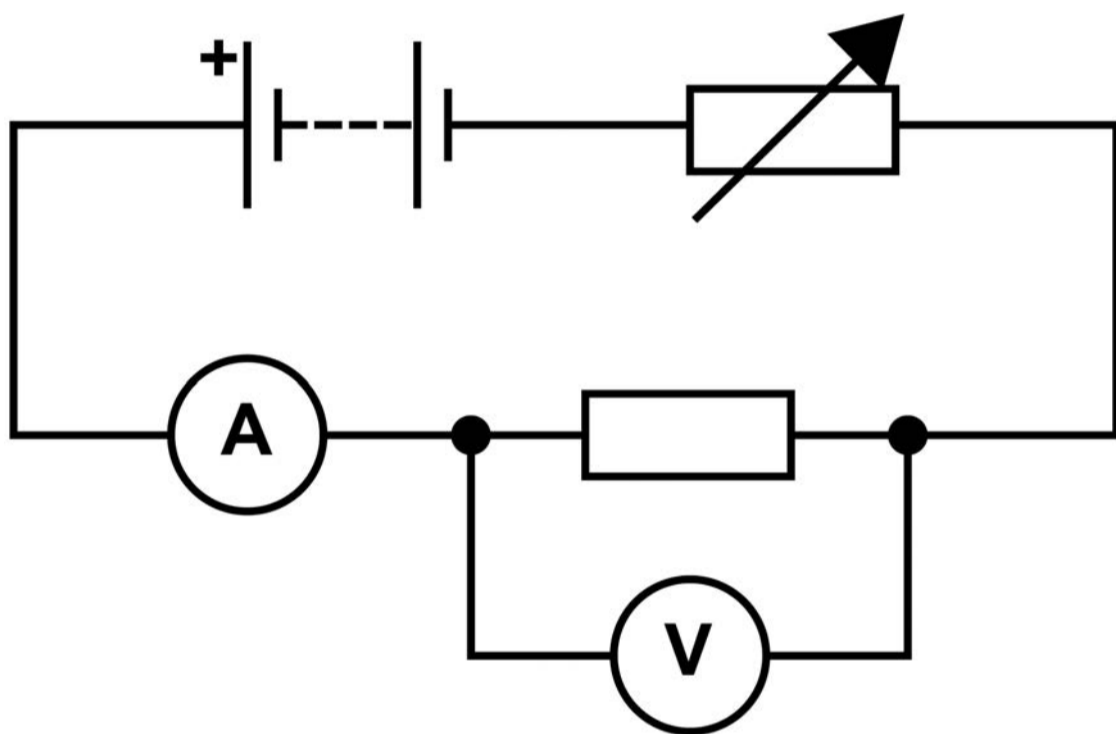
How does FIGURE 9 show that the student was NOT correct? [1 mark]

[Turn over]



FIGURE 10 shows a circuit the student built using the battery from the TENS machine.

FIGURE 10

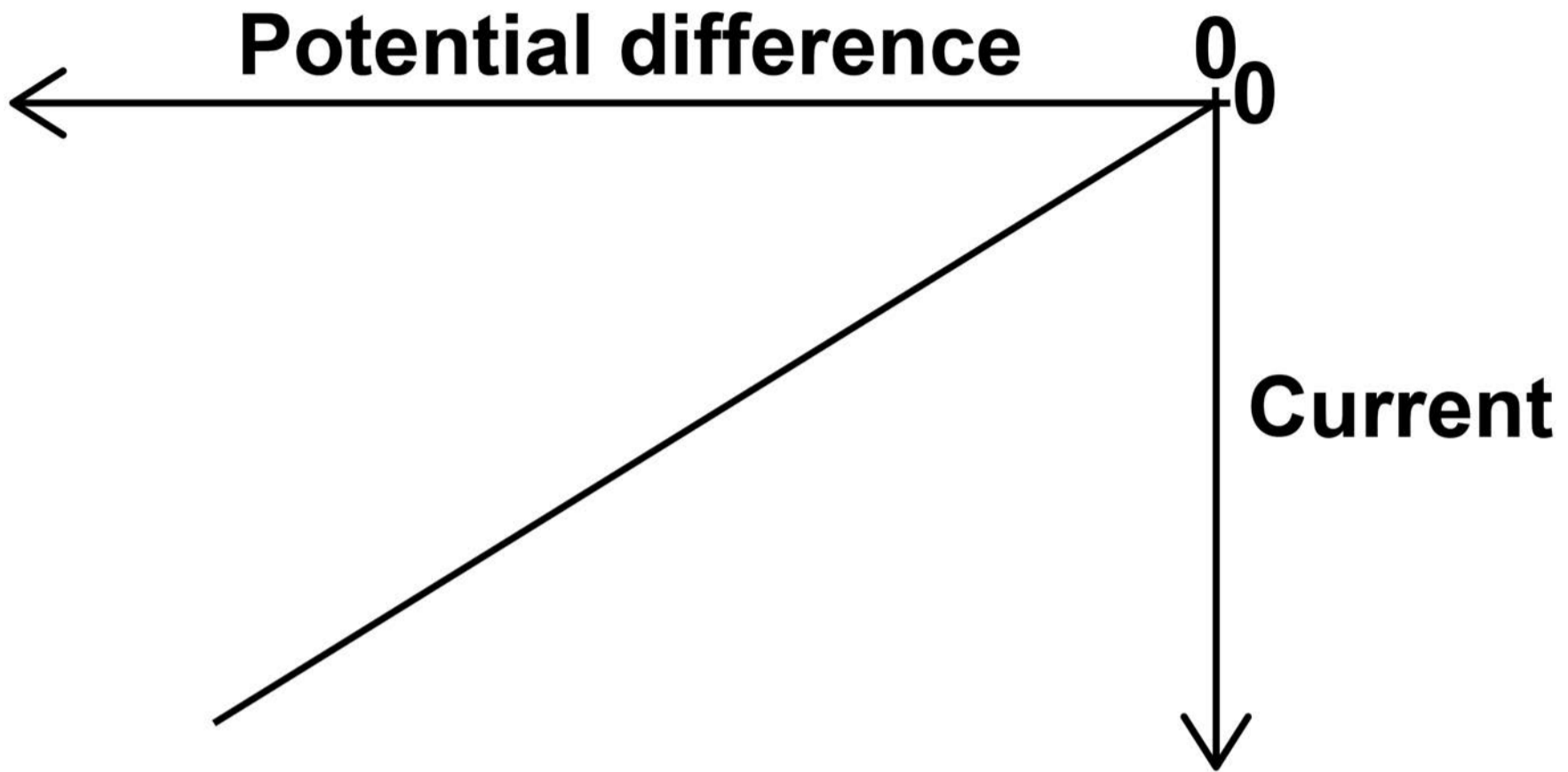


The student recorded how the current in the resistor varied with the potential difference across the resistor.

FIGURE 11, on the opposite page, shows a sketch graph of the results.



FIGURE 11



0	5	.	3
---	---	---	---

What relationship does FIGURE 11 show?
[1 mark]

[Turn over]



0	5	.	4
---	---	---	---

FIGURE 12, on page 46, shows two more circuits that the student built using the battery from the TENS machine.



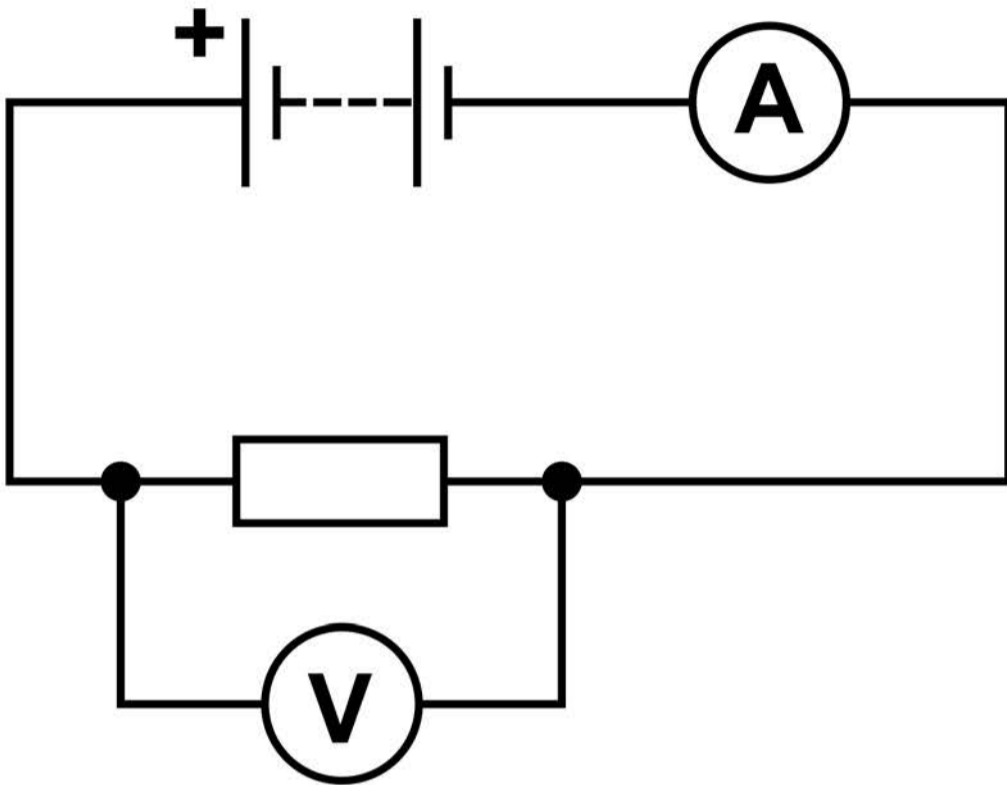
BLANK PAGE

[Turn over]

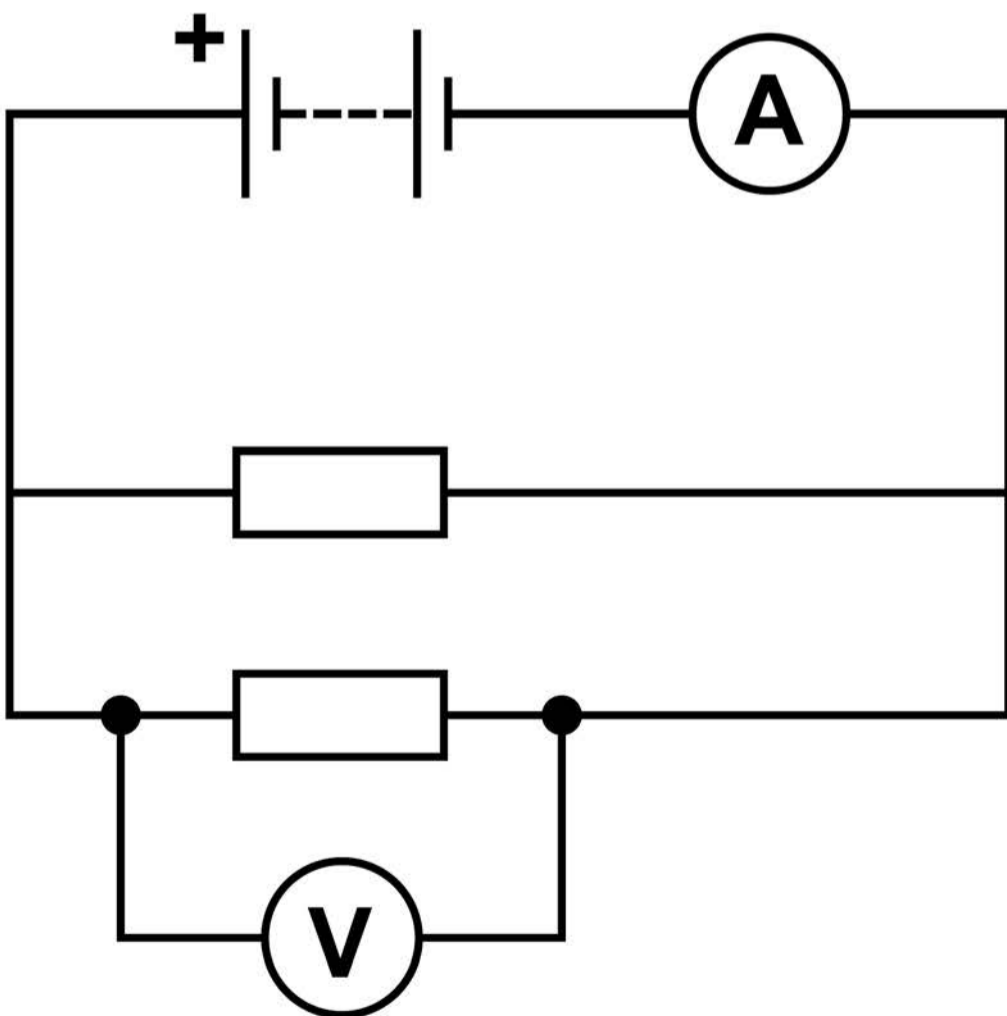


FIGURE 12

Circuit A



Circuit B



The resistors all have the same resistance.

Compare the readings on the voltmeter and ammeter in circuit A and circuit B.

[3 marks]

Voltmeter _____

Ammeter _____

[Turn over]

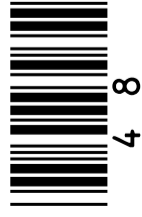
9



06

An air source heat pump transfers energy from the air outside a building to increase the temperature of the air inside the building.

FIGURE 13, on page 50, shows an air source heat pump.



The compressor is connected to the mains electricity supply.

The pipe in the heat pump contains a substance called coolant.

In the evaporator, energy is transferred from the air outside the building to the liquid coolant.

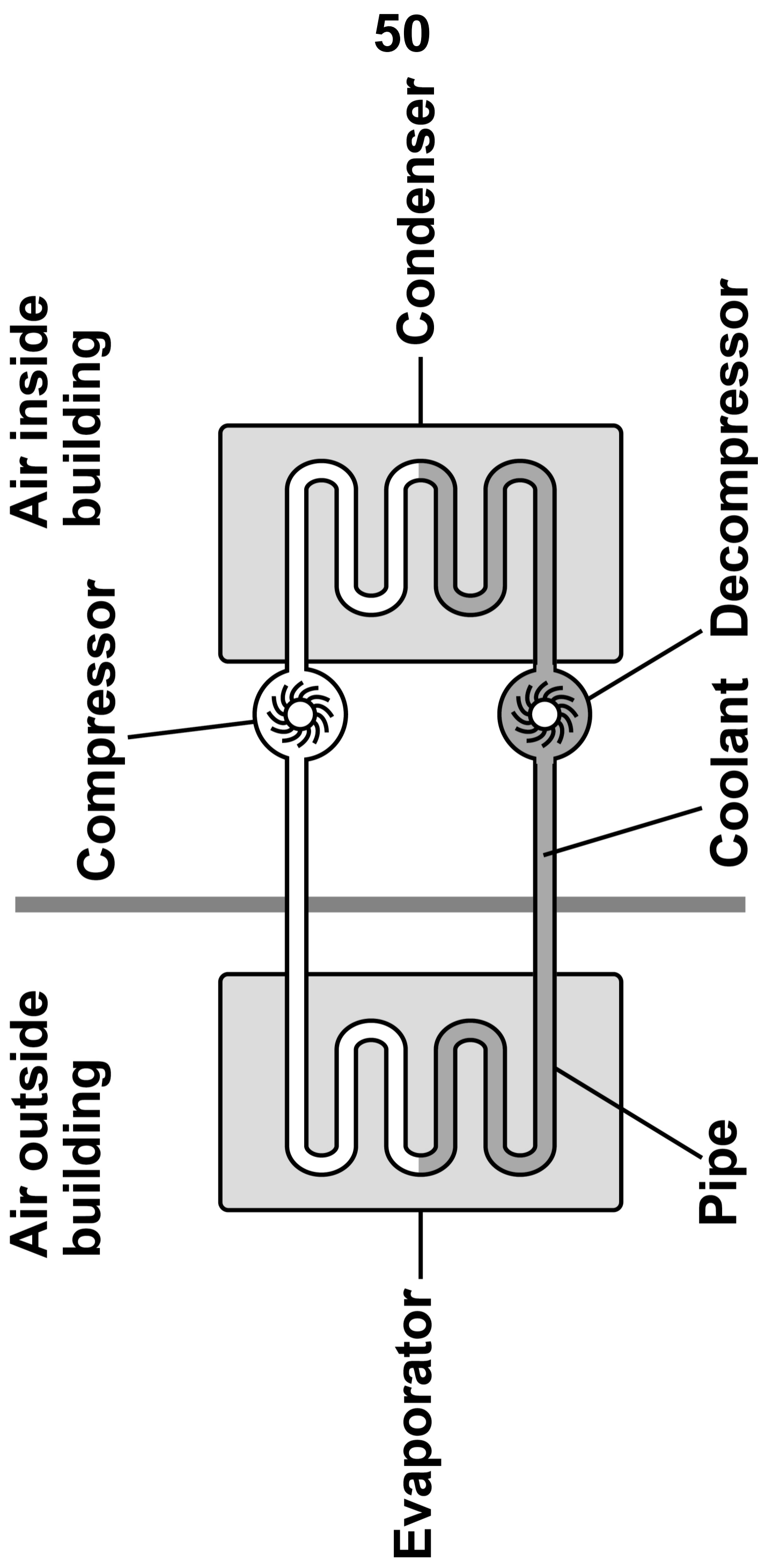
49

The temperature of the coolant increases and it evaporates.

[Turn over]



FIGURE 13



06.1

Explain what happens to the internal energy of the coolant as its temperature increases. [2 marks]

51

06.2

What name is given to the energy needed to change the state of the liquid coolant? [1 mark]



[Turn over]

0	6	.	3
---	---	---	---

**What happens to the mass of the coolant as it evaporates and becomes a vapour?
[1 mark]**

Tick (✓) ONE box.

Decreases

Stays the same

Increases



06.4

The compressor increases the density and temperature of the coolant vapour inside the pipe.

Explain why the pressure in the pipe increases. [2 marks]

[Turn over]



06.5

The condenser transfers energy from the coolant to the air in the building.

When the total energy input to the heat pump system is 1560 kJ the temperature of the air in the building increases from 11.6 °C to 22.1 °C.

The efficiency of the heat pump system is 87.5%.

The mass of the air inside the building is 125 kg.

Calculate the specific heat capacity of the air in the building.

**Give your answer in standard form.
[6 marks]**



Specific heat capacity (standard form) =
_____ J/kg °C

[Turn over]



06.6

The air in the building gains 400 J for every 100 J of energy transferred from the mains electricity supply to the compressor.

An advertisement claims that the heat pump system has an efficiency of 400%.

Explain why the advertisement is NOT correct. [3 marks]

END OF QUESTIONS

<hr/>
15



BLANK PAGE

For Examiner's Use	
Question	Mark
1	
2	
3	
4	
5	
6	
TOTAL	

Copyright information

For confidentiality purposes, all acknowledgements of third-party copyright material are published in a separate booklet. This booklet is published after each live examination series and is available for free download from www.aqa.org.uk.

Permission to reproduce all copyright material has been applied for. In some cases, efforts to contact copyright-holders may have been unsuccessful and AQA will be happy to rectify any omissions of acknowledgements. If you have any queries please contact the Copyright Team.

Copyright © 2021 AQA and its licensors. All rights reserved.

IB/M/CH/Jun21/8464/P/1H/E3



6 0



2 1 6 G 8 4 6 4 / P / 1 H