

A



Surname _____

Other Names _____

Centre Number _____

Candidate Number _____

Candidate Signature _____

I declare this is my own work.

GCSE

COMBINED SCIENCE: TRILOGY

Foundation Tier

Physics Paper 1F

F

8464/P/1F

Time allowed: 1 hour 15 minutes

At the top of the page, write your surname and other names, your centre number, your candidate number and add your signature.

[Turn over]



J U N 2 2 8 4 6 4 P 1 F 0 1

For this paper you must have:

- **a ruler**
- **a scientific calculator**
- **the Physics Equations Sheet (enclosed).**

INSTRUCTIONS

- **Use black ink or black ball-point pen.**
- **Pencil should only be used for drawing.**
- **Answer ALL questions in the spaces provided.**
- **If you need extra space for your answer(s), use the lined pages at the end of this book. Write the question number against your answer(s).**
- **Do all rough work in this book. Cross through any work you do not want to be marked.**



- **In all calculations, show clearly how you work out your answer.**

INFORMATION

- **The maximum mark for this paper is 70.**
- **The marks for questions are shown in brackets.**
- **You are expected to use a calculator where appropriate.**
- **You are reminded of the need for good English and clear presentation in your answers.**

DO NOT TURN OVER UNTIL TOLD TO DO SO



0 1

A student investigated how the potential difference across a filament lamp affects the current in the lamp.

FIGURE 1 shows the circuit the student used.

FIGURE 1

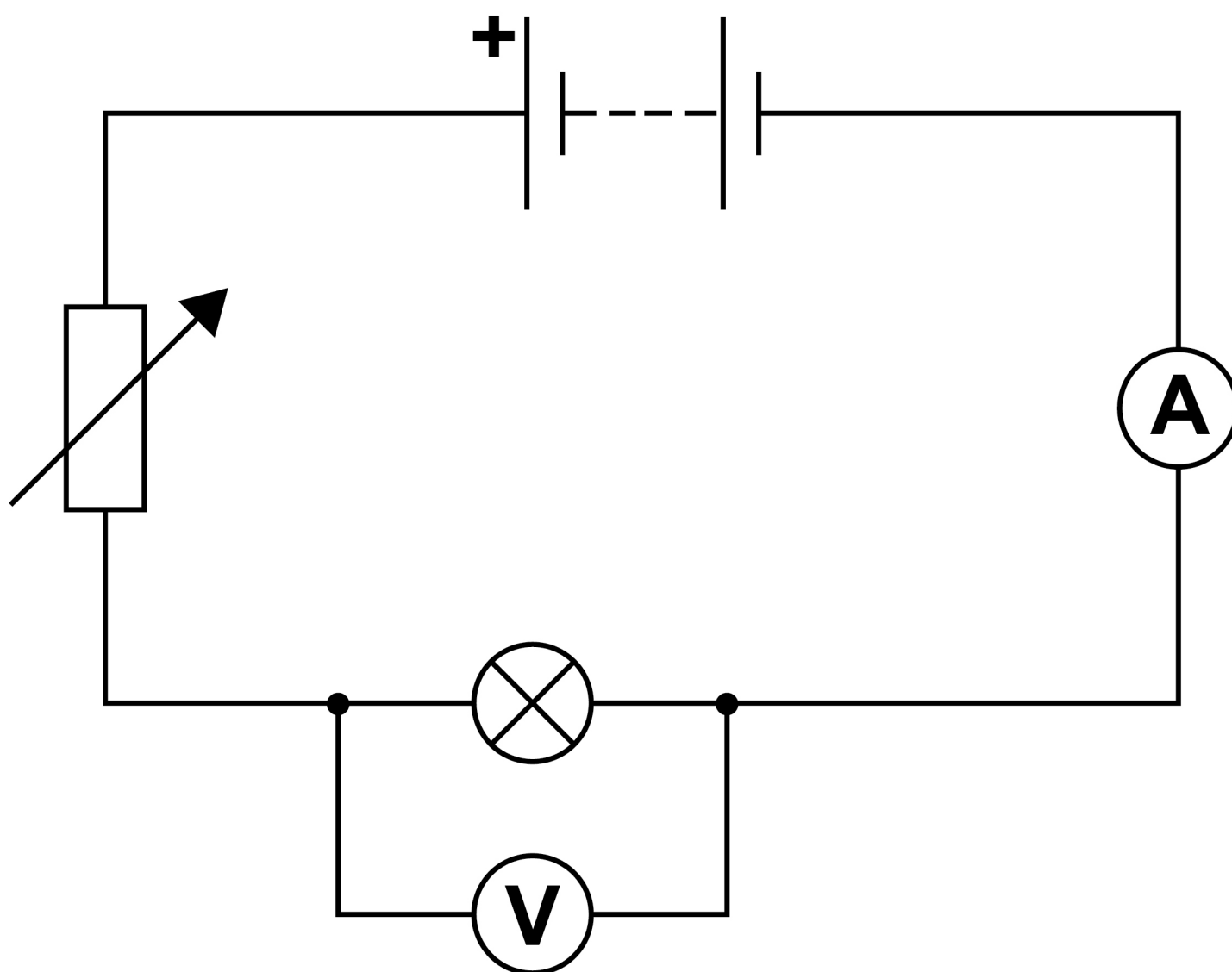

0	1	.	1
---	---	---	---

FIGURE 2 shows a circuit symbol.

FIGURE 2

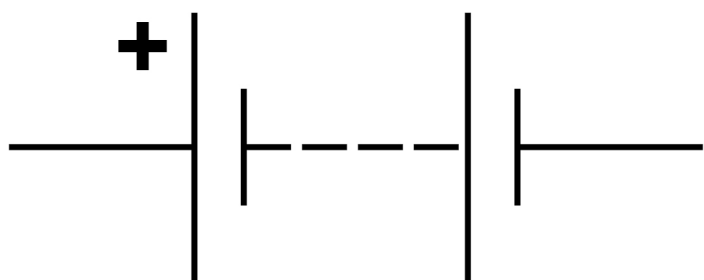

What component does the symbol represent? [1 mark]

Tick (✓) ONE box.

Ammeter

Battery

Lamp

Variable resistor

[Turn over]

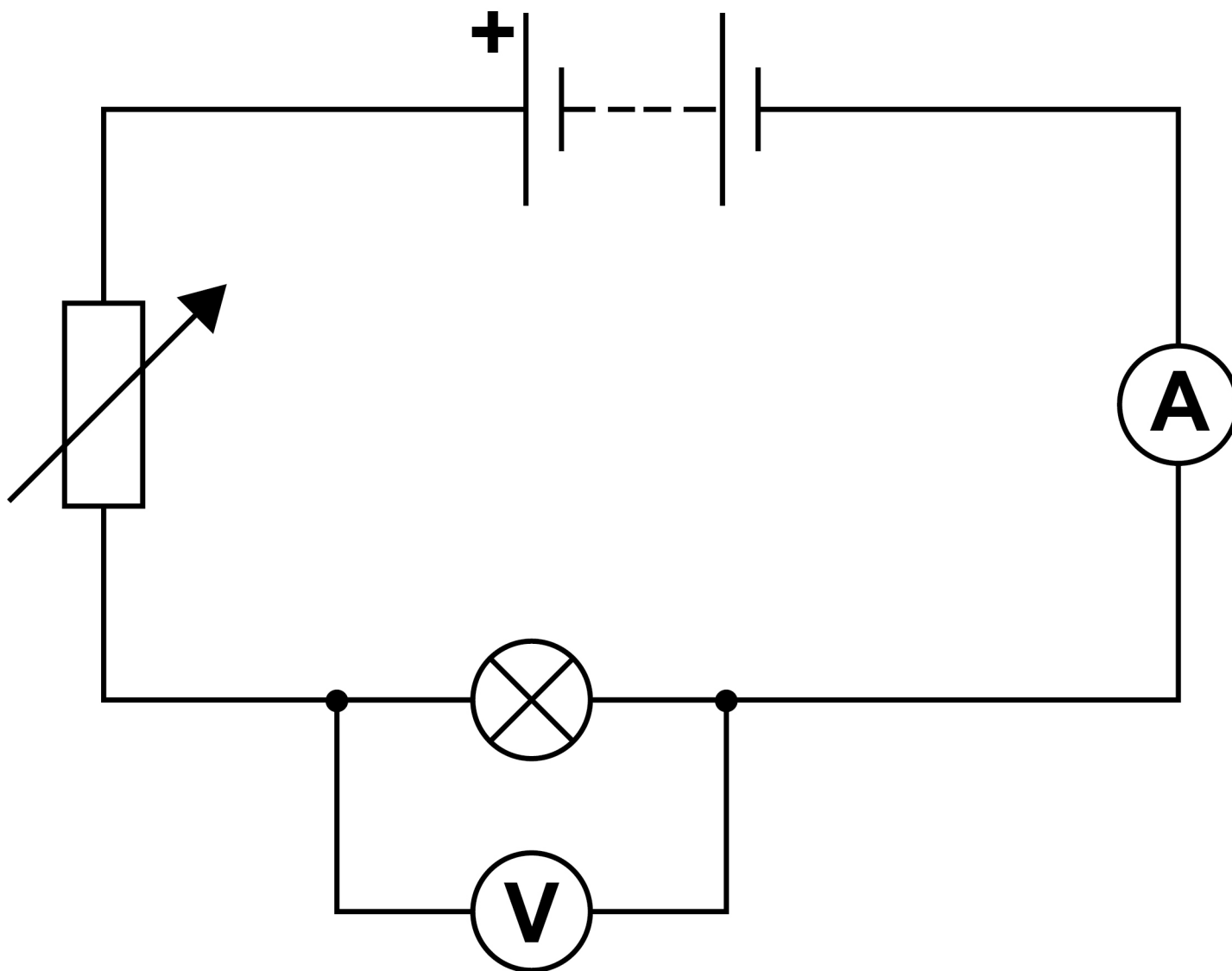

REPEAT OF FIGURE 1

0	1	.	2
---	---	---	---

Which component from FIGURE 1 did the student use to adjust the potential difference across the lamp? [1 mark]



0 **1** . **3**

When the voltmeter was NOT connected to the circuit it gave a reading of 0.4 volts.

**How can the student correct all the readings taken from the voltmeter?
[1 mark]**

Tick (✓) ONE box.

Add 0.4 volts to each reading

Divide each reading by 0.4 volts

Multiply each reading by 0.4 volts

Subtract 0.4 volts from each reading

[Turn over]



0 1 . 4

The student recorded three values of current for each potential difference.

TABLE 1 shows the results for 2.5 volts.

TABLE 1

Potential difference in volts	Current in amps		
	1	2	3
2.5	0.54	0.58	0.53

Calculate the mean current in the lamp.
[2 marks]



Mean current = _____ A

[Turn over]



0	1	.	5
---	---	---	---

Calculate the power of the lamp when the potential difference across the lamp was 4.8 V

The current in the lamp was 0.75 A

Use the equation:

power = potential difference × current

[2 marks]

Power = _____ W



0 1 . 6

Calculate the resistance of the lamp when the potential difference across the lamp was 4.8 V

The current in the lamp was 0.75 A

Use the equation:

$$\text{resistance} = \frac{\text{potential difference}}{\text{current}}$$

[2 marks]

Resistance = _____ Ω

[Turn over]



0	1	.	7
---	---	---	---

Complete the sentence.

Choose answers from the list.

Each answer may be used once, more than once or not at all. [2 marks]

- **decrease**
- **increase**
- **stay the same**

**Increasing the current in a filament lamp
makes the temperature of the lamp
_____ and the resistance
of the lamp _____.**



BLANK PAGE

[Turn over]



01.8

Which graph, below and on the opposite page, shows the relationship between potential difference and current for a filament lamp? [1 mark]

Tick (✓) ONE box.

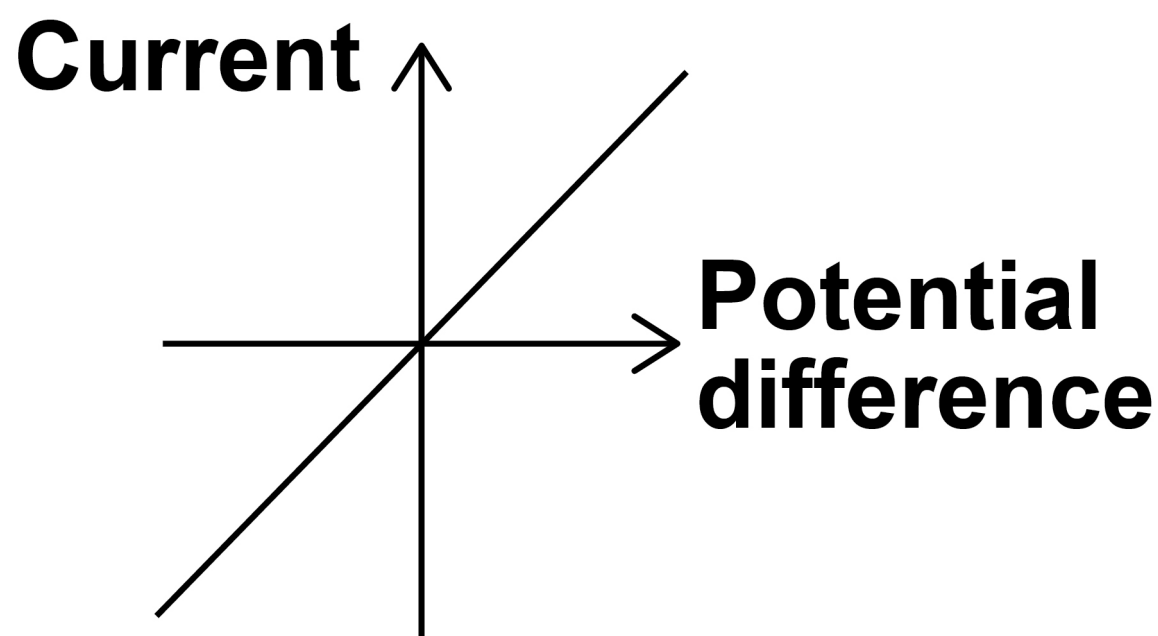
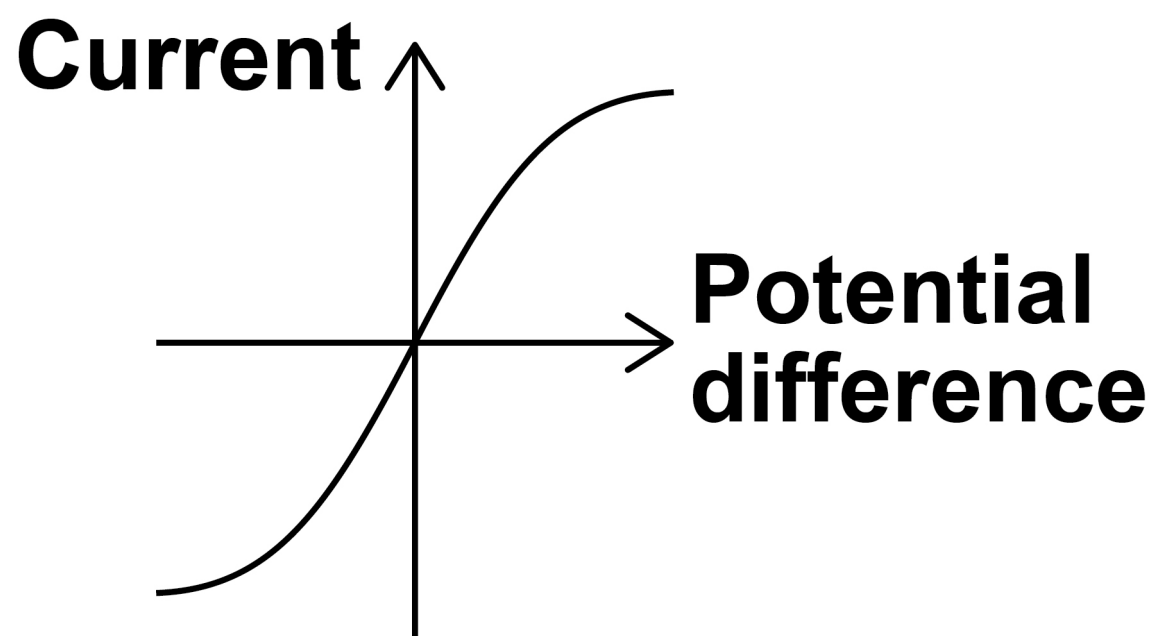

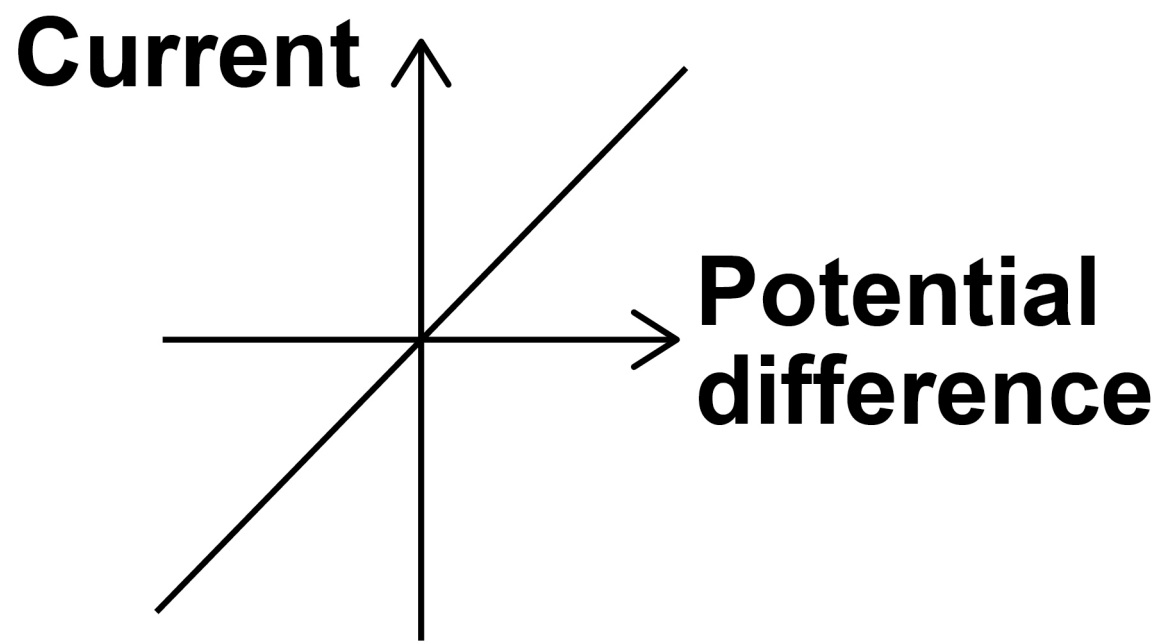
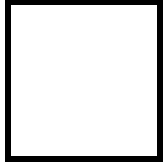

12

[Turn over]



0	2
---	---

FIGURE 3, on the opposite page, shows a lift near the bottom of a building.

The lift is attached by a cable to a counterweight.

An electric motor moves the lift.

The lift is moving up.

0	2	.	1
---	---	---	---

As the lift moves up, how far does the counterweight move down? [1 mark]

Tick (✓) ONE box.

A shorter distance than the lift.

The same distance as the lift.

A longer distance than the lift.



FIGURE 3

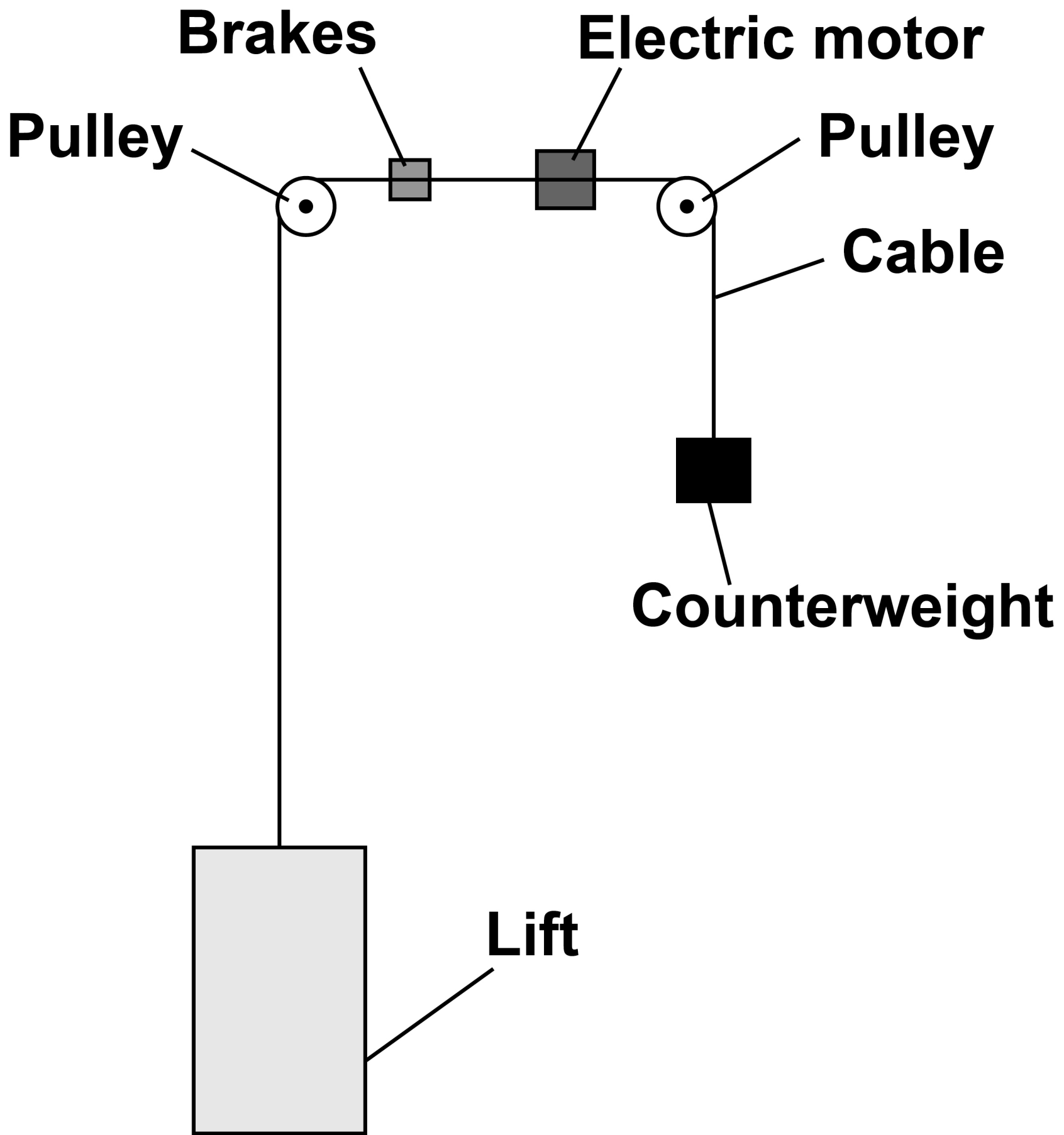

[Turn over]



REPEAT OF FIGURE 3

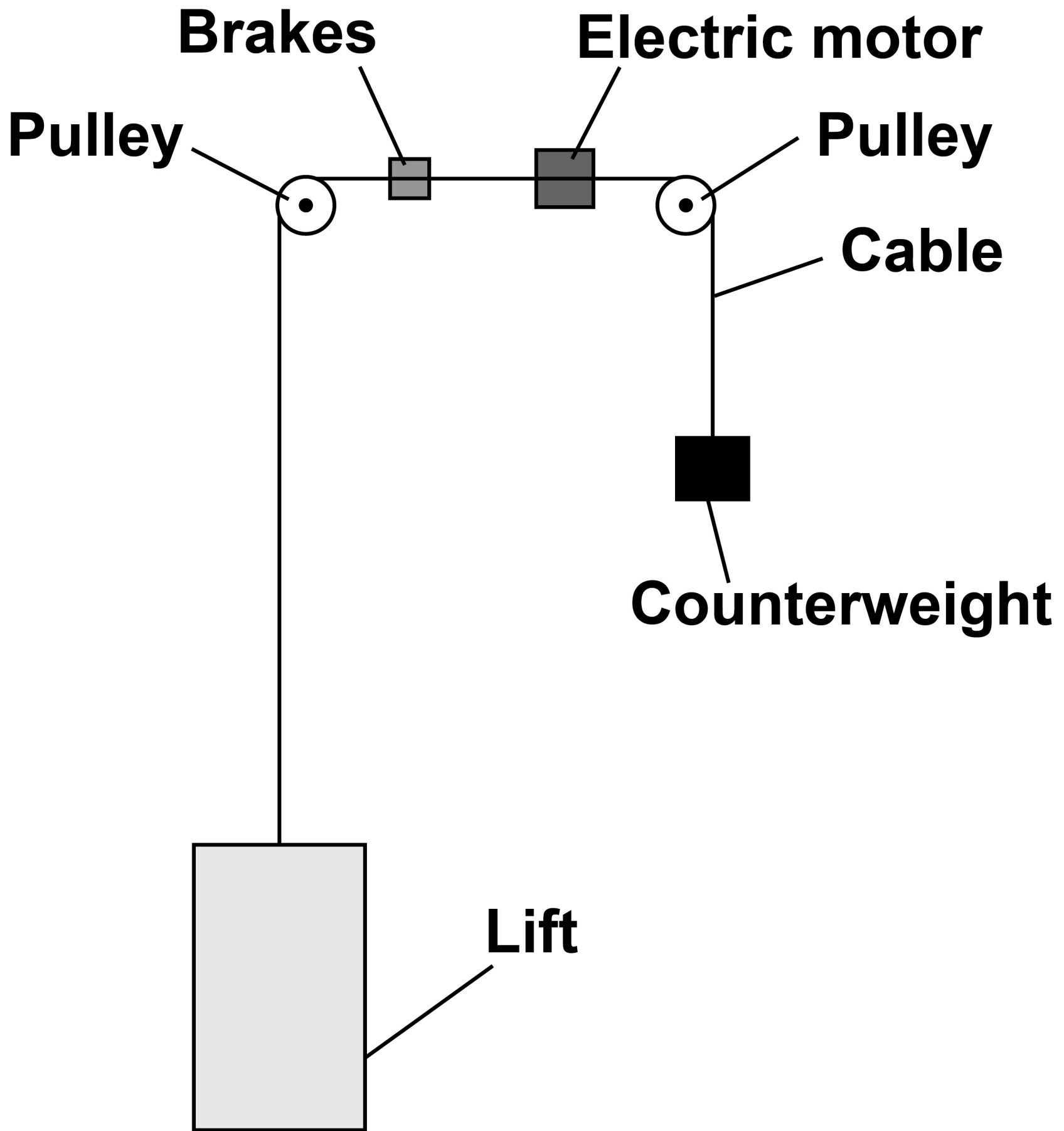

0 2 . 2

What happens to the gravitational potential energy of the counterweight as it moves down? [1 mark]

Tick (✓) ONE box.

It decreases

It stays the same

It increases

[Turn over]



0 2 . 3

Calculate the change in gravitational potential energy of the lift when it moves up 4.0 m

The mass of the lift is 1300 kg

gravitational field strength = 9.8 N/kg

Use the equation:

**gravitational potential energy =
mass × gravitational field strength ×
height**

[2 marks]



Change in gravitational potential energy =
_____ J

[Turn over]



0 2 . 4**Complete the sentences.****Choose answers from the list. [2 marks]**

- **chemical**
- **elastic potential**
- **gravitational potential**
- **internal**
- **kinetic**

Friction between the brakes and the cable causes the speed of the lift to decrease.

As the speed decreases, there is a decrease in the _____ energy of the lift.



As the speed decreases, there is an increase in the _____ energy of the brakes.

[Turn over]



0 2 . 5

The motor transfers different amounts of energy each time people use the lift.

Which factors affect the amount of energy transferred by the motor as the lift moves? [2 marks]

Tick (✓) TWO boxes.

The distance moved by the lift

The height of the building

The length of the steel cable

The maximum power of the motor

The weight of the people in the lift



BLANK PAGE

[Turn over]



0 2 . 6

The weight of the lift and the counterweight stretch the cable by 0.015 m

The cable acts like a spring with a spring constant of 880 000 N/m

Calculate the elastic potential energy of the stretched cable.

Use the equation:

**elastic potential energy =
 $0.5 \times \text{spring constant} \times (\text{extension})^2$**

[2 marks]



Elastic potential energy = _____ J

[Turn over]

0 2 . 7

A lift system using a counterweight is more efficient than a lift system that does not use a counterweight.

How does having a more efficient system affect the energy transferred by the motor? [1 mark]

Tick (✓) ONE box.

Less energy is transferred.

The same amount of energy is transferred.

More energy is transferred.

11



BLANK PAGE

[Turn over]



0	3
---	---

A teacher demonstrated that the radioactive isotope americium-241 emits alpha particles.

FIGURE 4 shows the equipment used.

FIGURE 4

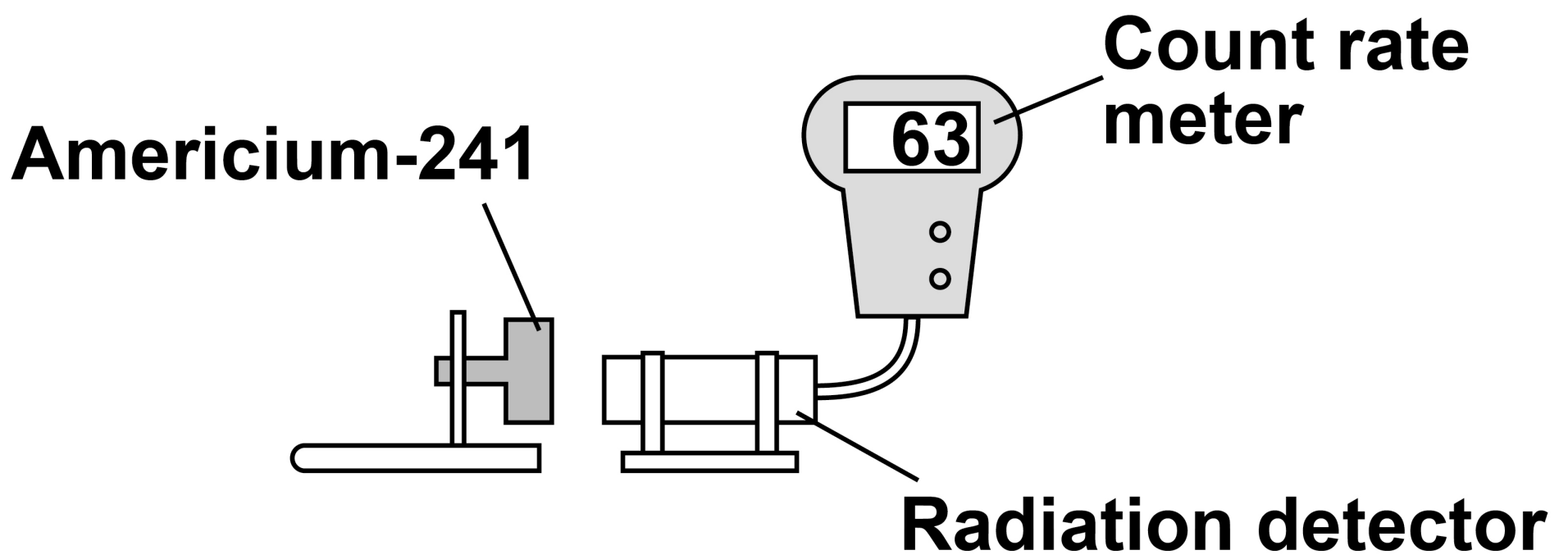

0	3	.	1
---	---	---	---

An americium-241 nucleus (Am) emits an alpha particle and turns into a neptunium nucleus (Np).

Which is the correct nuclear equation for this decay? [1 mark]

Tick (✓) ONE box.

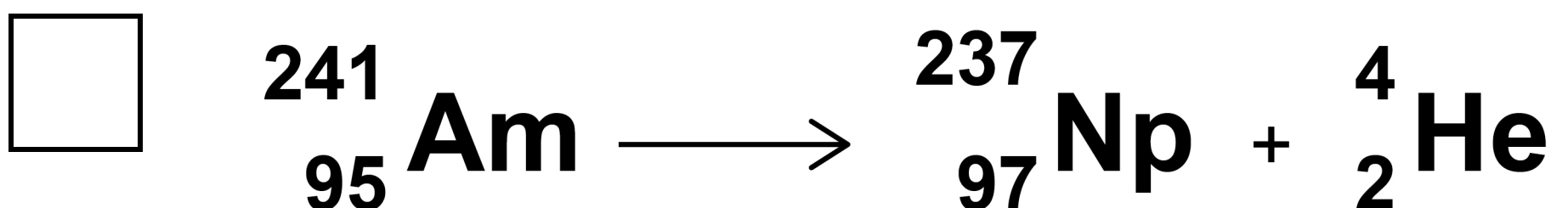
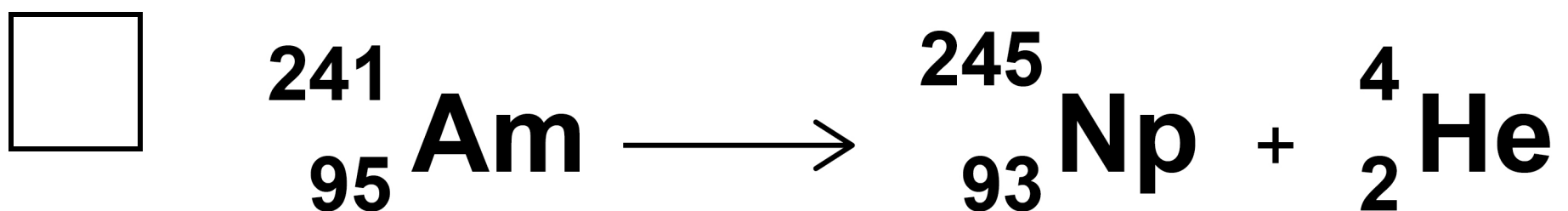
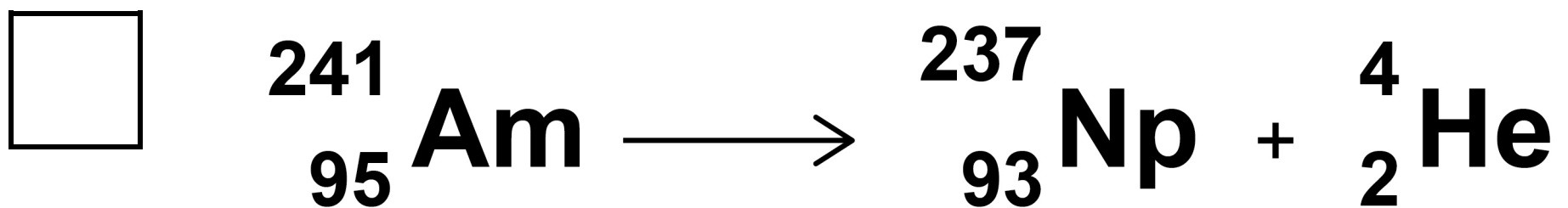

[Turn over]



0	3	.	2
---	---	---	---

What is the furthest distance that alpha radiation can travel in air? [1 mark]

Tick (✓) ONE box.

A few millimetres

A few centimetres

A few metres



0	3	.	3
---	---	---	---

The teacher placed a piece of paper between the americium-241 and the radiation detector.

The reading on the count rate meter decreased by a large amount.

Why does the decreased reading show that americium-241 emits alpha radiation? [1 mark]

Tick (✓) ONE box.

Paper stops alpha radiation.

Paper stops all types of radiation.

Paper stops beta and gamma radiation.

[Turn over]



The teacher replaced the americium-241 with a source of beta radiation.

0 3 . 4

Which symbol represents a beta particle? [1 mark]

Tick (✓) ONE box.

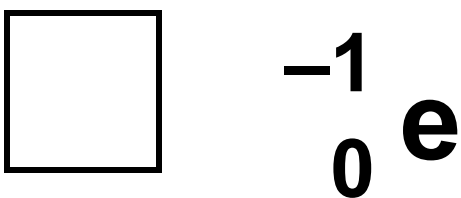
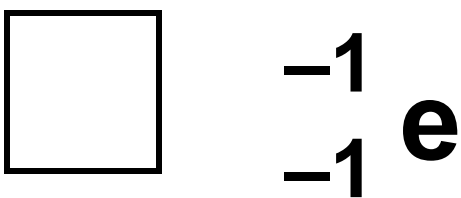
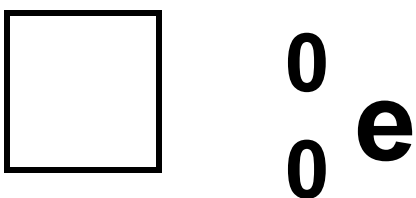
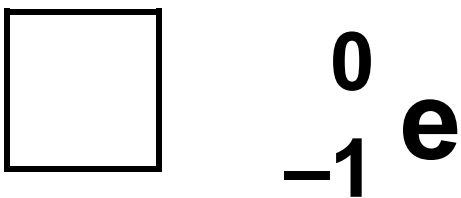

0	3	.	5
---	---	---	---

The count rate from the source was 119 ± 7 counts per second.

Calculate the smallest count rate this could have been. [1 mark]

Smallest count rate =

_____ counts per second

[Turn over]



A teacher investigated how the distance between a different radioactive source and the detector affects the count rate.

0 3 . 6

On the opposite page, draw ONE line from each type of variable to the description. [3 marks]



TYPE OF VARIABLE

DESCRIPTION

Count rate

Control variable

Distance between the source and detector

Dependent variable

Radioactive source

Independent variable

Time

[Turn over]



03.7

FIGURE 5 shows how the count rate from the different radioactive source changed with the distance from the source.

FIGURE 5

Count rate in counts per second

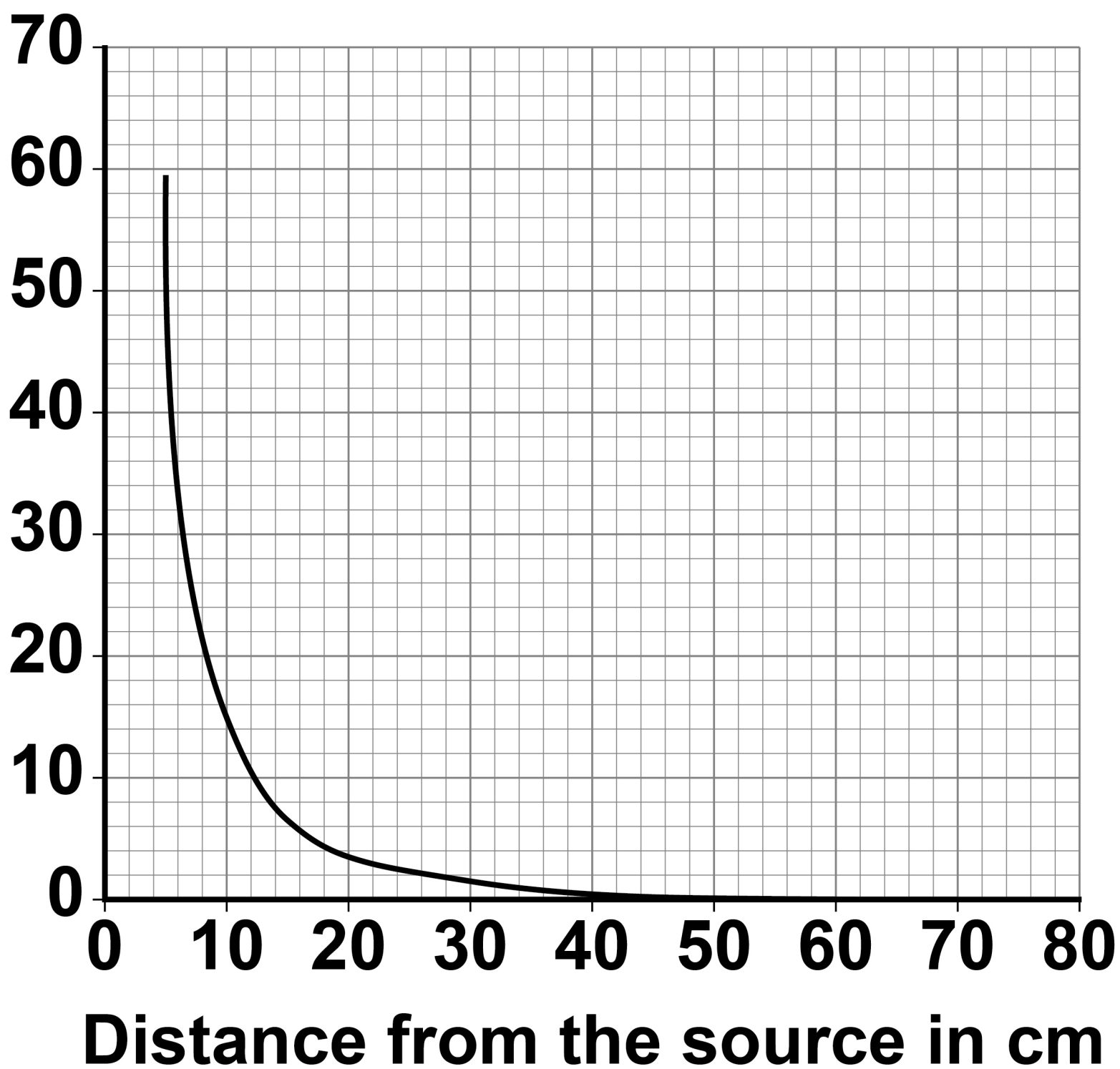

Describe the relationship between the distance from the source and the count rate. [2 marks]

[Turn over]

10

0	4
---	---

FIGURE 6 shows a swimmer wearing a wetsuit.

The wetsuit helps to keep the swimmer warm.

FIGURE 6



A student wrapped a thermometer in a piece of wetsuit material and placed the thermometer in water containing ice.

FIGURE 7, on page 42, shows the apparatus.



BLANK PAGE

[Turn over]



FIGURE 7

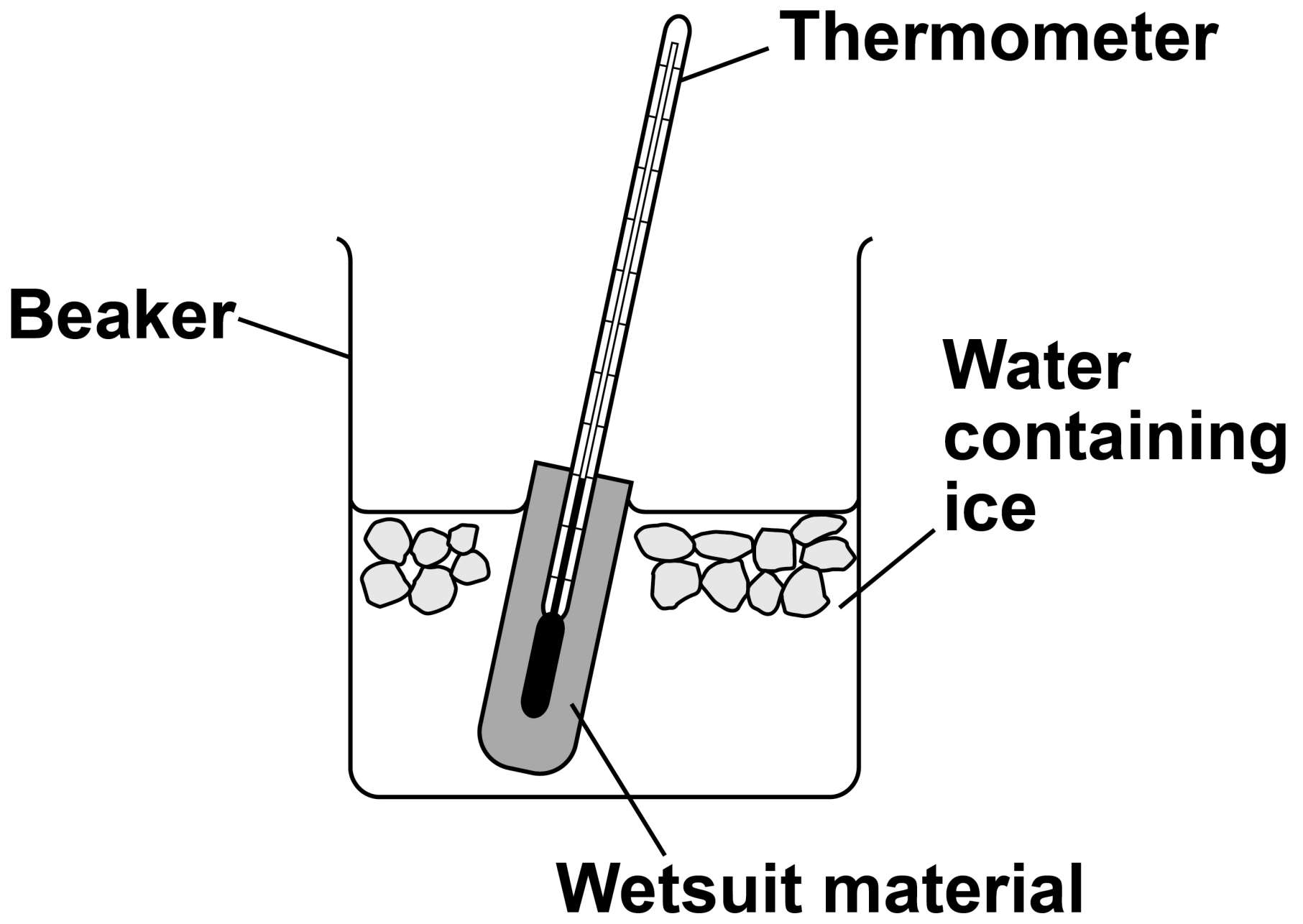

0	4	.	1
---	---	---	---

After 30 seconds in the water the temperature of the thermometer had decreased by 7.5 °C

Calculate the average decrease in temperature each second. [2 marks]

Average decrease in temperature each second = _____ °C

[Turn over]



The student recorded the temperature of the thermometer after 30 seconds for four materials. Each piece of material was the same size and thickness.

In each test the starting temperature of the thermometer was 21.0 °C

TABLE 2 shows the results.

TABLE 2

Material	W	X	Y	Z
Temperature in °C	13.5	8.0	16.0	12.0

0 4 . 2

Complete FIGURE 8, on the opposite page, using the data in TABLE 2.

You should:

- label the *y*-axis
- draw the bars for materials Y and Z.

[2 marks]



FIGURE 8

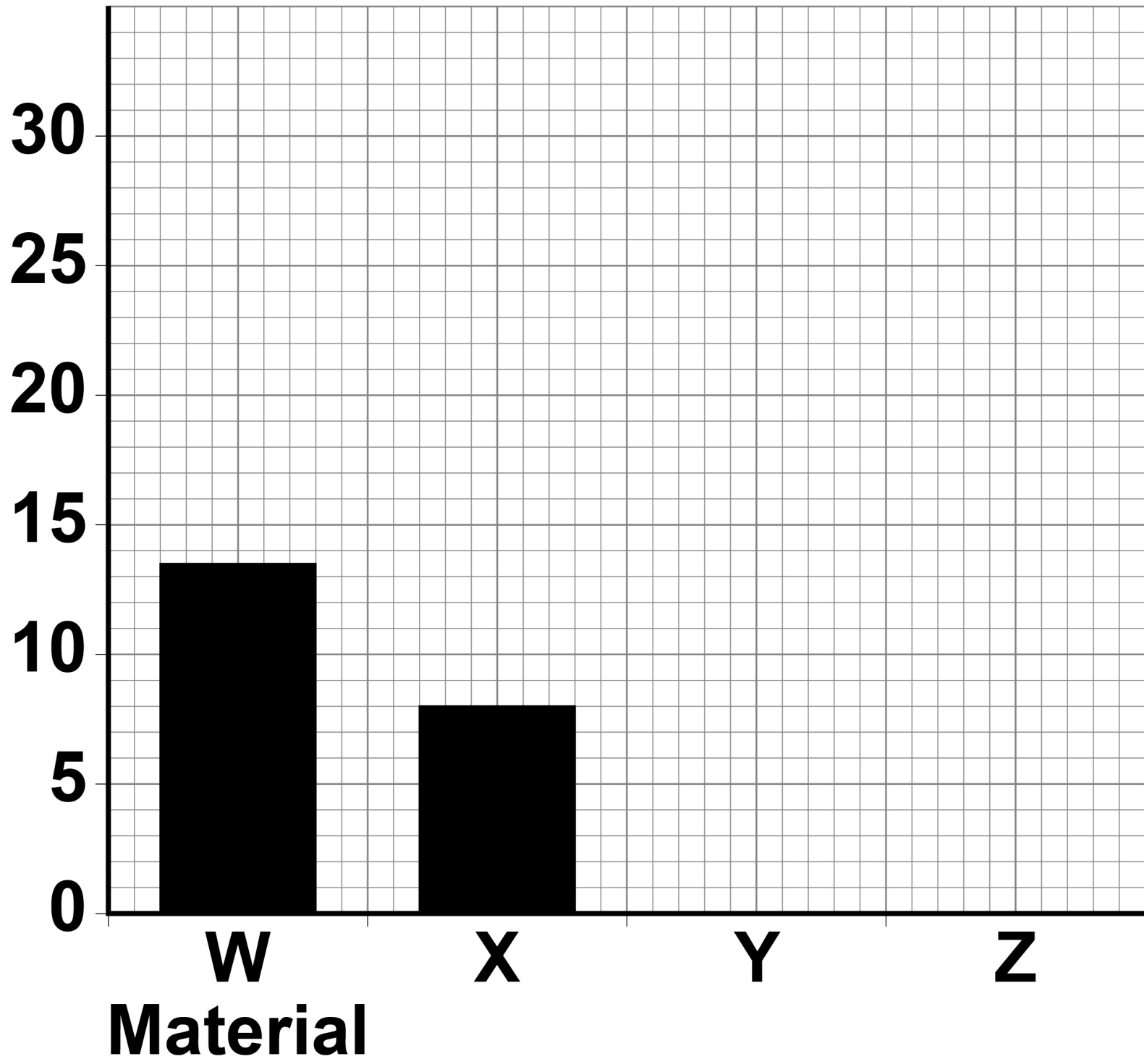

[Turn over]



BLANK PAGE



0 4 . 3

Which material is the best thermal insulator?

Give a reason for your answer. [2 marks]

Tick (✓) ONE box.

W**X****Y****Z**

Reason _____

[Turn over]



0	4	.	4
---	---	---	---

The student tested a new material with a greater thermal conductivity than material Z.

The piece of new material was the same size and thickness as the piece of material Z.

What was the temperature of the thermometer after 30 seconds? [1 mark]

Tick (✓) ONE box.

Less than 12.0 °C

Exactly 12.0 °C

Greater than 12.0 °C

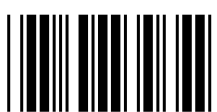

BLANK PAGE

[Turn over]



04.5

During the investigation 0.0150 kg of the ice melted. The temperature of the water and ice did not change.

**specific latent heat of fusion of ice =
334 000 J/kg**

Calculate the energy needed to melt the ice.

Use the equation:

energy to melt the ice = mass × specific latent heat

[2 marks]



Energy needed to melt the ice =

_____ J

[Turn over]

The student wanted to determine the density of a wetsuit material.

The student measured the length of one side of a cube of wetsuit material with:

- **a micrometer**
- **a ruler.**

TABLE 3, on page 54, shows the results.



BLANK PAGE

[Turn over]



TABLE 3

Equipment	Length in cm		
	Measurement 1	Measurement 2	Measurement 3
Micrometer	0.581	0.557	0.576
Ruler	0.6	0.6	0.6



0 4 . 6

Complete the sentence.

Choose the answer from the list. [1 mark]

- **calibration**
- **precision**
- **reproducibility**
- **resolution**

55

The results show that compared to the ruler the micrometer has a higher _____.

[Turn over]



Use the Physics Equations Sheet to answer questions 04.7 and 04.8.

04.7

Write down the equation that links density (ρ), mass (m) and volume (V).
[1 mark]

04.8

The student calculated the volume of the cube of wetsuit material to be 0.186 cm^3

The density of the cube was 0.300 g/cm^3



0	5
---	---

FIGURE 9, on the opposite page, shows some of the energy resources used to meet the demand for electrical power in the UK on one day in 2020.

The key for FIGURE 9 is provided below.

KEY

1 = Demand

2 = Gas

3 = Nuclear

4 = Wind

5 = Coal



FIGURE 9

Electrical power in gigawatts

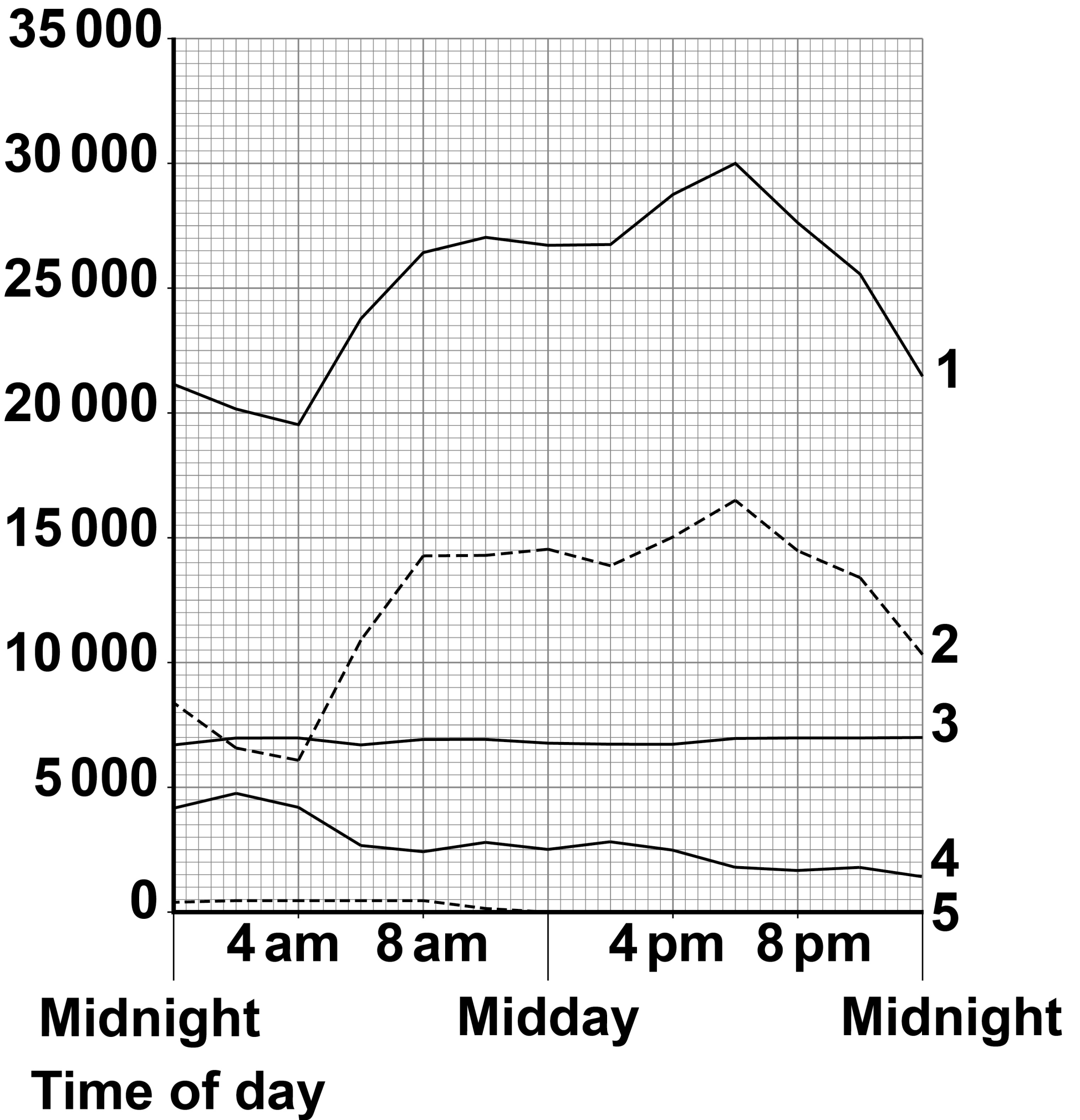

[Turn over]



BLANK PAGE

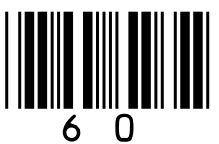

05.2

The UK government wants to reduce carbon emissions as much as possible.

Which energy resources need to be used less to achieve this? [1 mark]

Tick (✓) ONE box.

Coal and gas

Gas and nuclear

Wind and coal

Wind and nuclear



A network of transformers and transmission cables transfers electrical power from power stations to consumers.

0 5 . 3

What is this network called? [1 mark]

[Turn over]

BLANK PAGE

[Turn over]



06

A student made measurements to determine the specific heat capacity of vegetable oil.

FIGURE 10 shows the equipment used.

FIGURE 10

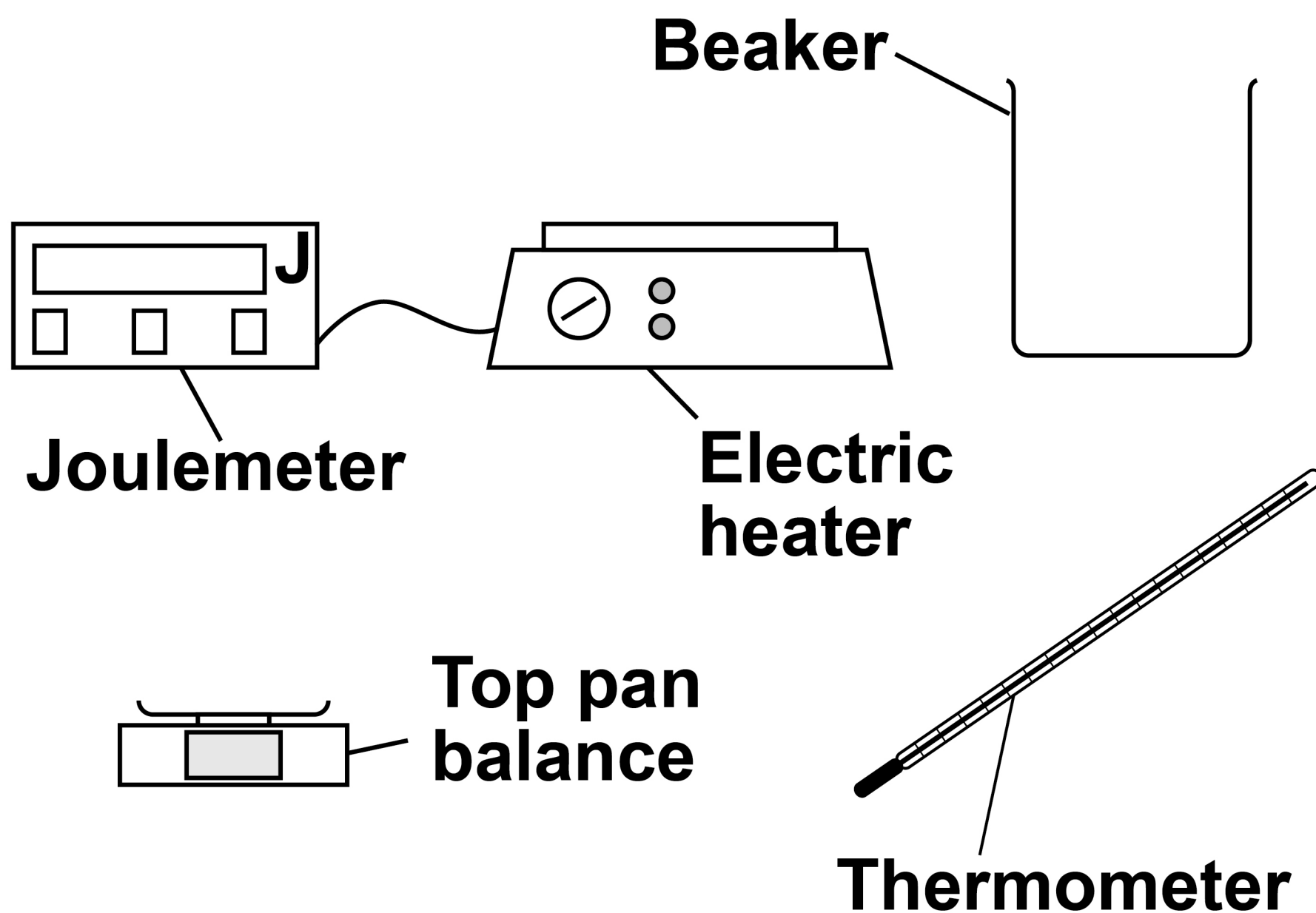

06.1

Describe how the student could use the equipment shown in FIGURE 10 to determine the specific heat capacity of vegetable oil. [6 marks]

[Turn over]



06.2

Give ONE risk when using the equipment in FIGURE 10, on page 66. [1 mark]

BLANK PAGE

[Turn over]



A different student did not have a joulemeter and calculated the energy transferred by the electric heater.

Use the Physics Equations Sheet to answer questions 06.3 and 06.4.

06.3

**Write down the equation linking energy transferred (E), power (P) and time (t).
[1 mark]**



0	6	.	4
---	---	---	---

The electric heater had a power output of 50 watts.

Calculate the time taken for the electric element to transfer 4750 joules of energy to the vegetable oil. [3 marks]

Time taken = _____ s

[Turn over]



In a deep fryer, vegetable oil is heated by an electric heating element. Food is then cooked in the hot vegetable oil.

The deep fryer contains an electrical component to monitor the temperature of the vegetable oil.

FIGURE 11, on the opposite page, shows how the resistance of this electrical component changes with temperature.

0 6 . 5

What electrical component is used to monitor the temperature of the vegetable oil? [1 mark]

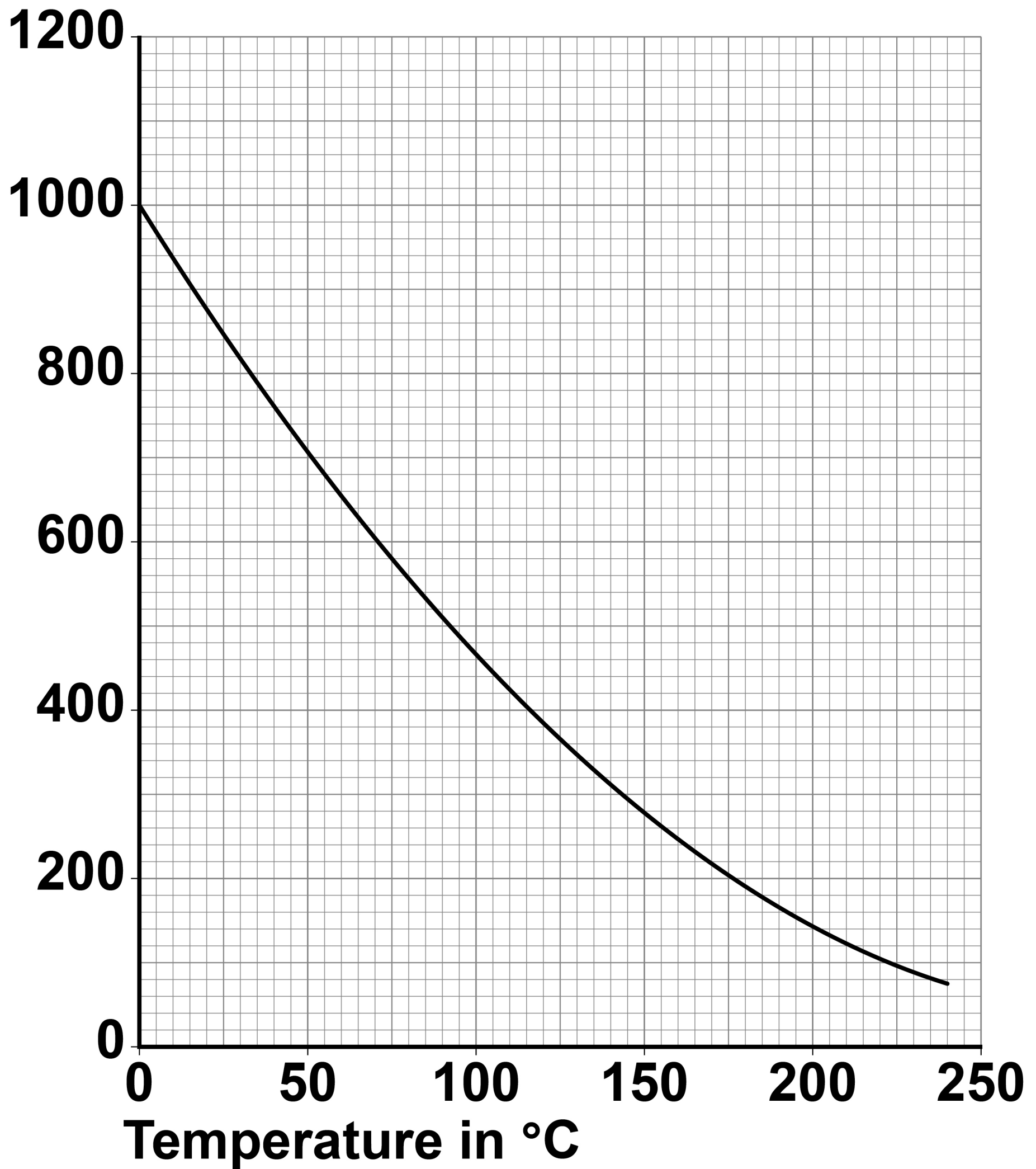

FIGURE 11**Resistance
in ohms****[Turn over]**

06.6

The electric heating element in the deep fryer automatically switches off when the vegetable oil reaches a certain temperature.

FIGURE 12, on page 76, shows how the temperature of the vegetable oil changed after the deep fryer was switched on.



BLANK PAGE

[Turn over]



FIGURE 12

Temperature
in °C

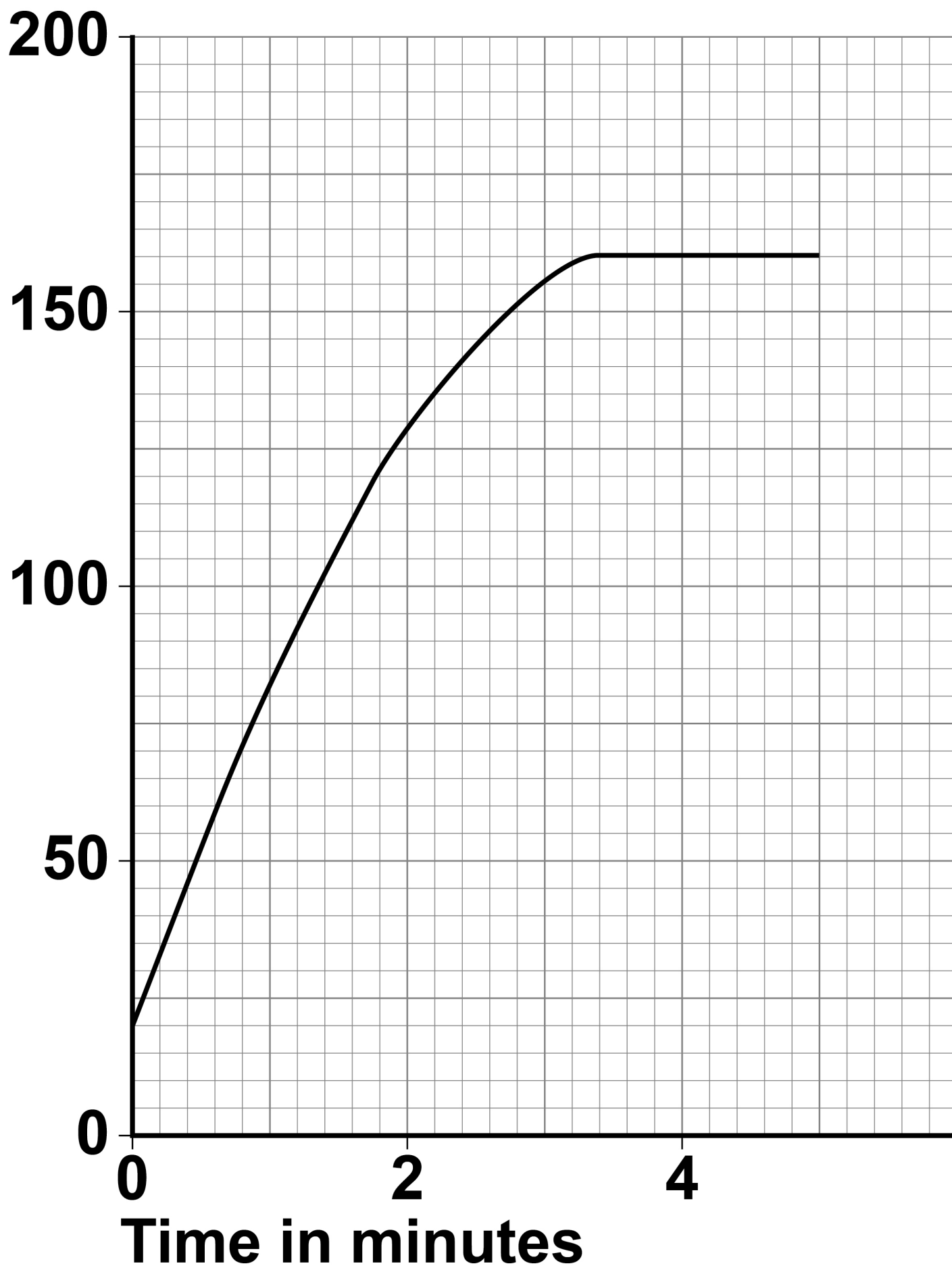

Determine the resistance of the electrical component when the electric heating element automatically switched off.

**Use FIGURE 11, on page 73, and FIGURE 12, on the opposite page.
[2 marks]**

Resistance = _____ Ω

[Turn over]



06.7

Some chips were put in the deep fryer.

In the deep fryer, water in the chips underwent a physical change and became steam.

Why is this a physical change? [1 mark]

Tick (✓) ONE box.

All water can change to steam.

No chemicals are involved when water changes to steam.

The change from water to steam can be detected visually.

The water will recover its original properties if the steam is cooled.

END OF QUESTIONS

15



**Additional page, if required.
Write the question numbers in the
left-hand margin.**

BLANK PAGE

For Examiner's Use	
Question	Mark
1	
2	
3	
4	
5	
6	
TOTAL	

Copyright information

For confidentiality purposes, all acknowledgements of third-party copyright material are published in a separate booklet. This booklet is published after each live examination series and is available for free download from www.aqa.org.uk.

Permission to reproduce all copyright material has been applied for. In some cases, efforts to contact copyright-holders may have been unsuccessful and AQA will be happy to rectify any omissions of acknowledgements. If you have any queries please contact the Copyright Team.

Copyright © 2022 AQA and its licensors. All rights reserved.

IB/M/CD/Jun22/8464/P/1F/E2

8 2



2 2 6 G 8 4 6 4 / P / 1 F