

A



Surname _____

Forename(s) _____

Centre Number _____

Candidate Number _____

Candidate Signature _____

I declare this is my own work.

Functional Skills Level 1

MATHEMATICS

Paper 2 Calculator

8361/2

Thursday 3 November 2022 Afternoon

Time allowed: 1 hour 30 minutes

At the top of the page, write your surname and forename(s), your centre number, your candidate number and add your signature.

[Turn over]



N 0 V 2 2 8 3 6 1 2 0 1

MATERIALS

For this paper you must have:

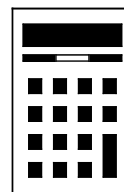

- a calculator
- mathematical instruments.

INSTRUCTIONS

- Use black ink or black ball-point pen. Draw diagrams in pencil.
- Answer ALL questions.
- You must answer the questions in the spaces provided. Do not write on blank pages.
- If you need extra space for your answer(s), use the lined pages at the end of this book. Write the question number against your answer(s).
- Do all rough work in this book. Cross through any work you do not want to be marked.



- **State the units of your answer where appropriate.**

INFORMATION

- **The marks for questions are shown in brackets.**
- **The maximum mark for this paper is 60.**
- **You may ask for more answer paper, graph paper and tracing paper. These must be tagged securely to this answer book.**

ADVICE

In all calculations, show clearly how you work out your answer.

DO NOT TURN OVER UNTIL TOLD TO DO SO



SECTION A

Answer ALL questions in the spaces provided.

1 A fair six-sided dice is rolled.

Which letter shows the probability of landing on an even number?

Circle your answer. [1 mark]

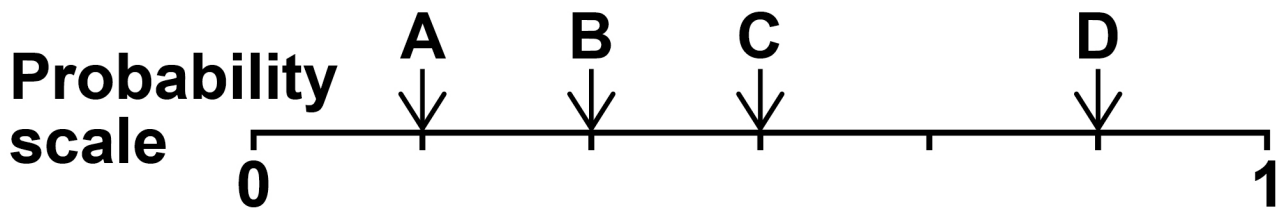

- 2 Circle the fraction with the same value as $3\frac{3}{4}$ [1 mark]

$$\frac{9}{4}$$

$$\frac{10}{4}$$

$$\frac{13}{4}$$

$$\frac{15}{4}$$

- 3 Measure the size of angle x [1 mark]

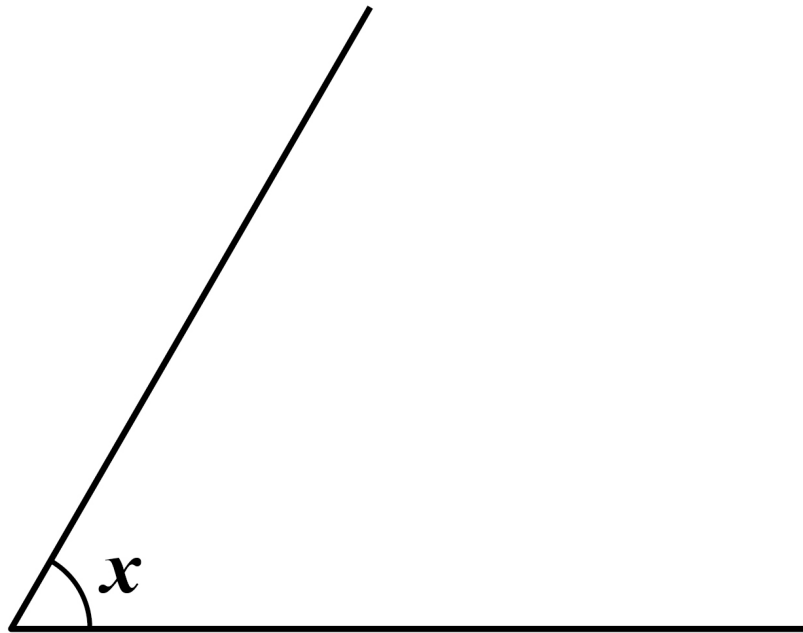

Answer _____ °

[Turn over]



4 Calculate -5×-6 [1 mark]

Answer _____

5 The front elevation and side elevation of a shape are shown.

FRONT ELEVATION

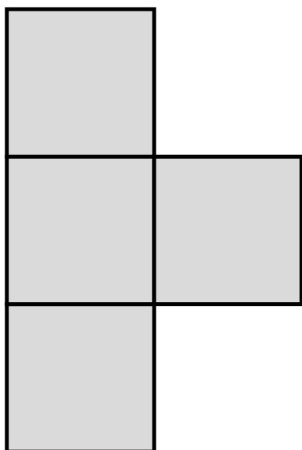

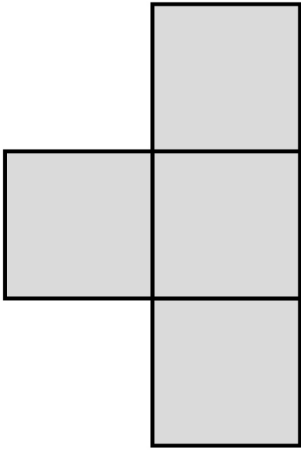
SIDE ELEVATION

Which shape has these elevations?

Circle the correct letter. [1 mark]

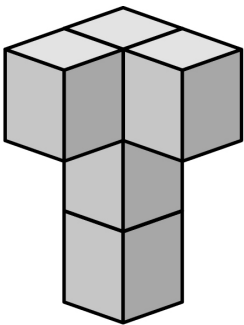
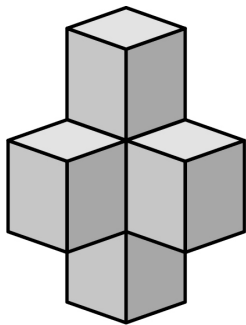
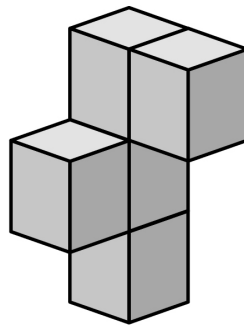
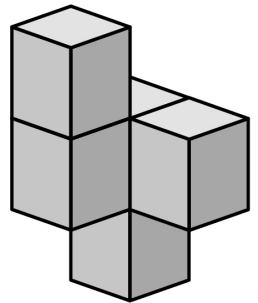
A**B****C****D**

[Turn over]



6 Round 14.76 to one decimal place.
[1 mark]

Answer _____

7 Here are six numbers.

16 19 16 10 17 12

Work out the mean. [3 marks]

Answer _____

8 Increase 630 by 40% [3 marks]

[Turn over]

12



SECTION B

Answer ALL questions in the spaces provided.

9 THE KITCHEN FITTER

Ryan is a kitchen fitter.

9 (a) A customer wants cupboards along one wall of her kitchen.

Ryan can choose from these cupboards.

LARGE

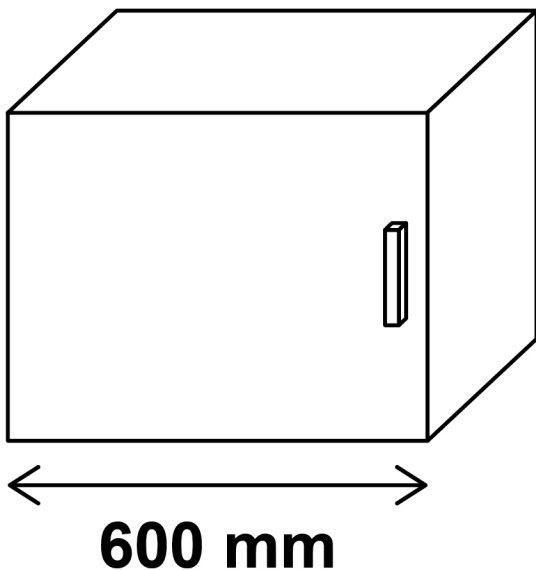

SMALL

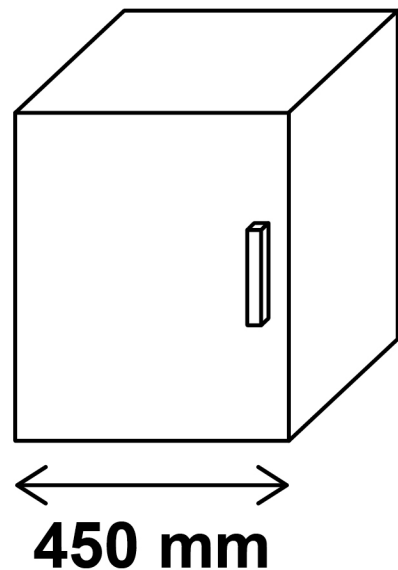

He can choose some of each size.

**The length of the wall is
3.45 METRES.**

**How many of each cupboard could
Ryan choose so that they fit the
length of the wall with no gaps?
[4 marks]**

[Turn over]



Number of large cupboards

Number of small cupboards



BLANK PAGE

[Turn over]



9 (b) A different customer wants

**3 large cupboards with width
600 mm and depth 600 mm**

**2 small cupboards with width
450 mm and depth 600 mm**

LARGE

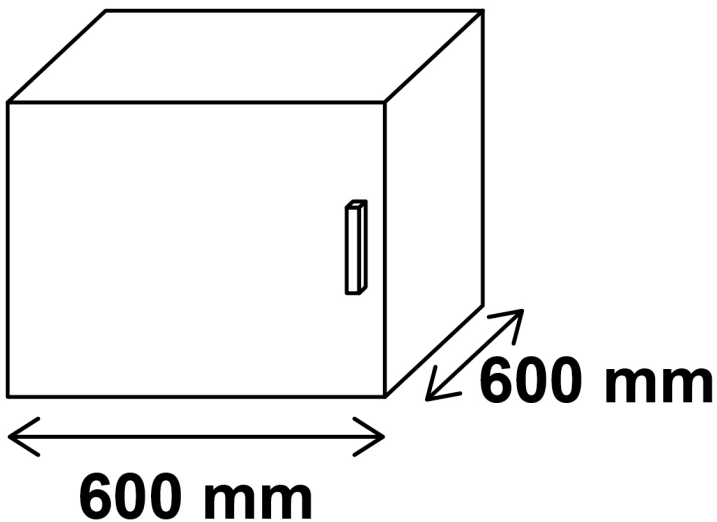

SMALL

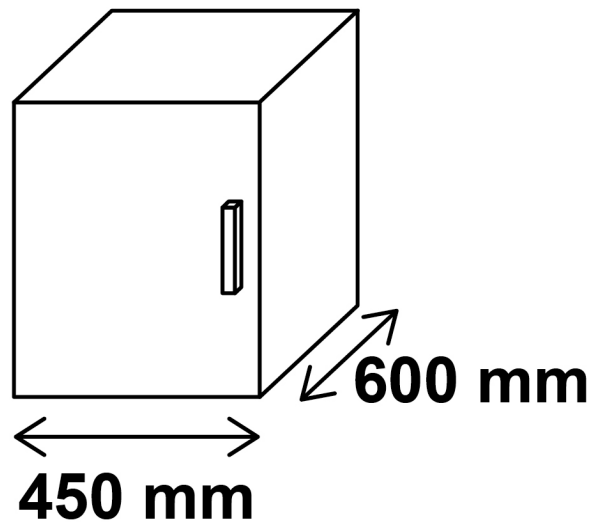

BLANK PAGE

[Turn over]



The cupboards will fit along ONE wall of this customer's kitchen.

The grid on the page opposite shows a scale drawing of the kitchen.

**The scale is
1 cm represents 150 mm**

**Use the grid to draw a plan of where Ryan could fit the cupboards.
[4 marks]**

SCALE: 1 cm represents 150 mm

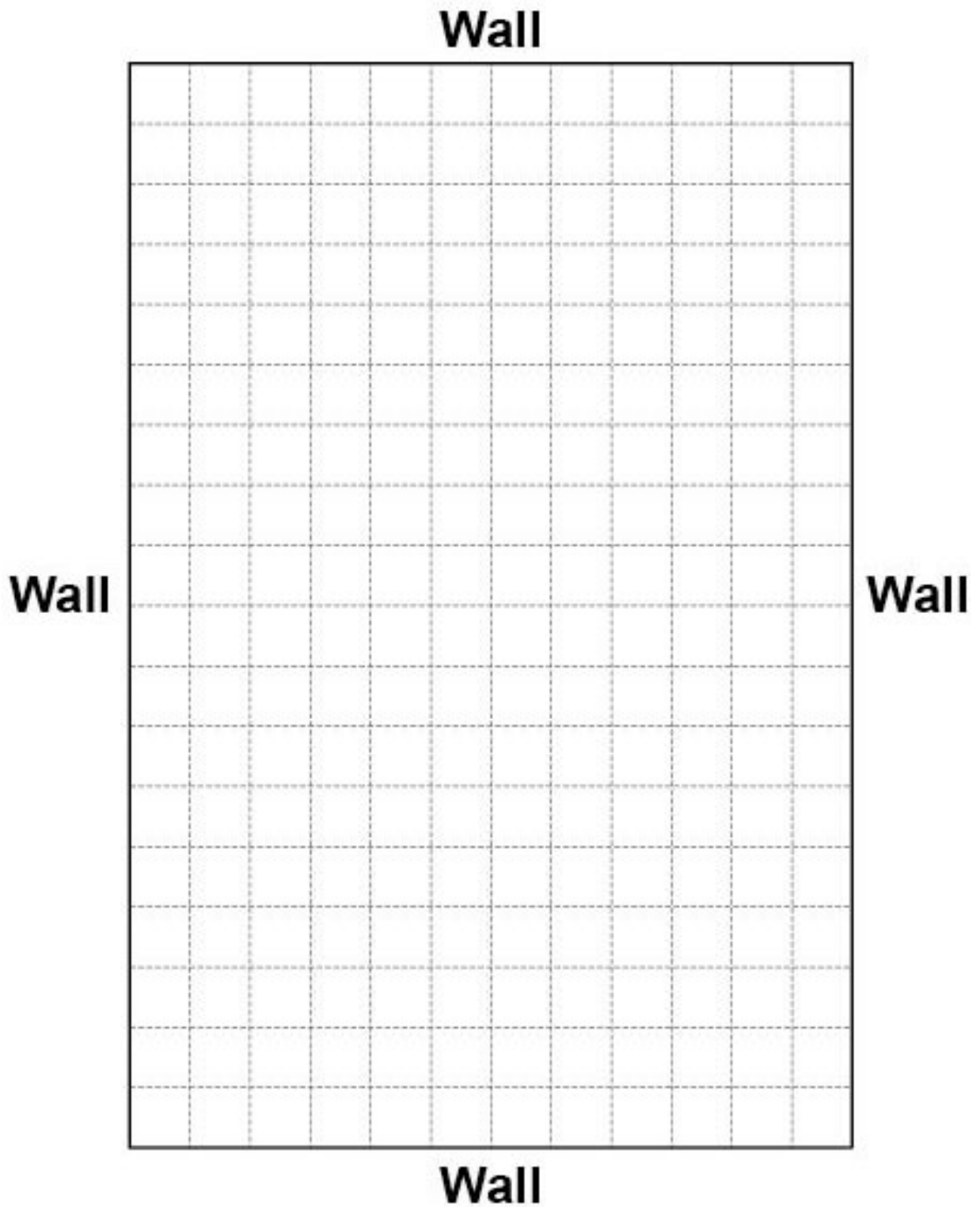

[Turn over]



9 (c) This is the price list for Ryan's kitchen cupboards.

	Price per cupboard
Large cupboard	£85.50
Small cupboard	£75.00

There is a special offer.

Large cupboards

Buy one, get one half price

A customer wants to order

6 large cupboards

and

2 small cupboards.



The customer has a budget of £550

Does the customer have enough money to buy these cupboards?

**You MUST show your working.
[5 marks]**

[Turn over]



13



10 FLOWER FARM

Erik grows daffodils on his farm.



[Turn over]

10 (a) This is a sketch of a field where Erik will grow daffodils.

It is not drawn accurately.

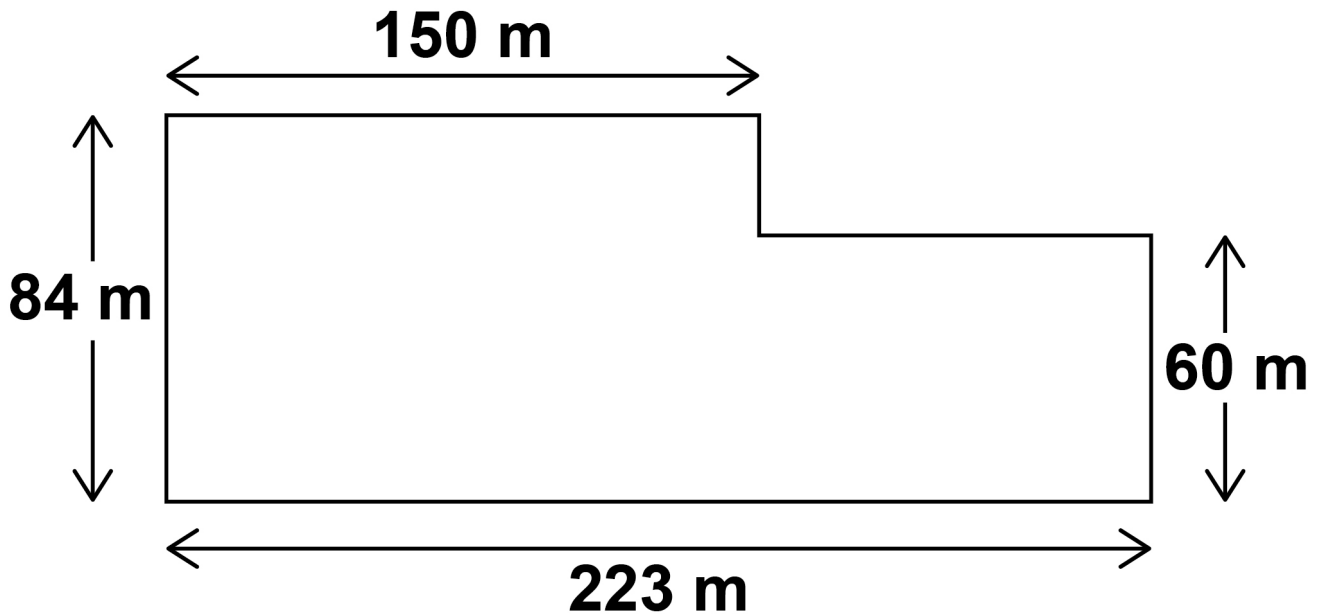

Erik plants 1.25 kg of daffodil bulbs per square metre of land.

He has 20 tonnes of bulbs.

1 tonne = 1000 kg

Does Erik have enough bulbs to plant all of this field?



You MUST show your working.
[5 marks]

[Turn over]



10 (b) Joe picks flowers on Erik's farm.

Joe is paid £8.29 for each box he fills with flowers.

The flower-picking season lasts for 10 weeks.

The list shows the number of boxes Joe filled each week for the first 5 weeks.

55 47 45 44 59

Estimate how much Joe can expect to earn for the full 10-week season.

**You MUST show your working.
[4 marks]**

Answer £ _____

[Turn over]



10 (c) Erik plants different types of daffodils in his fields.

Here is some data about the area he planted with each type of daffodil.

Type of daffodil	Area planted (m²)
Golden Ducat	88 000
White Lion	72 000
Ice Follies	46 000
Pink Pride	34 000

**On the opposite page, draw a suitable chart to show this data.
[4 marks]**



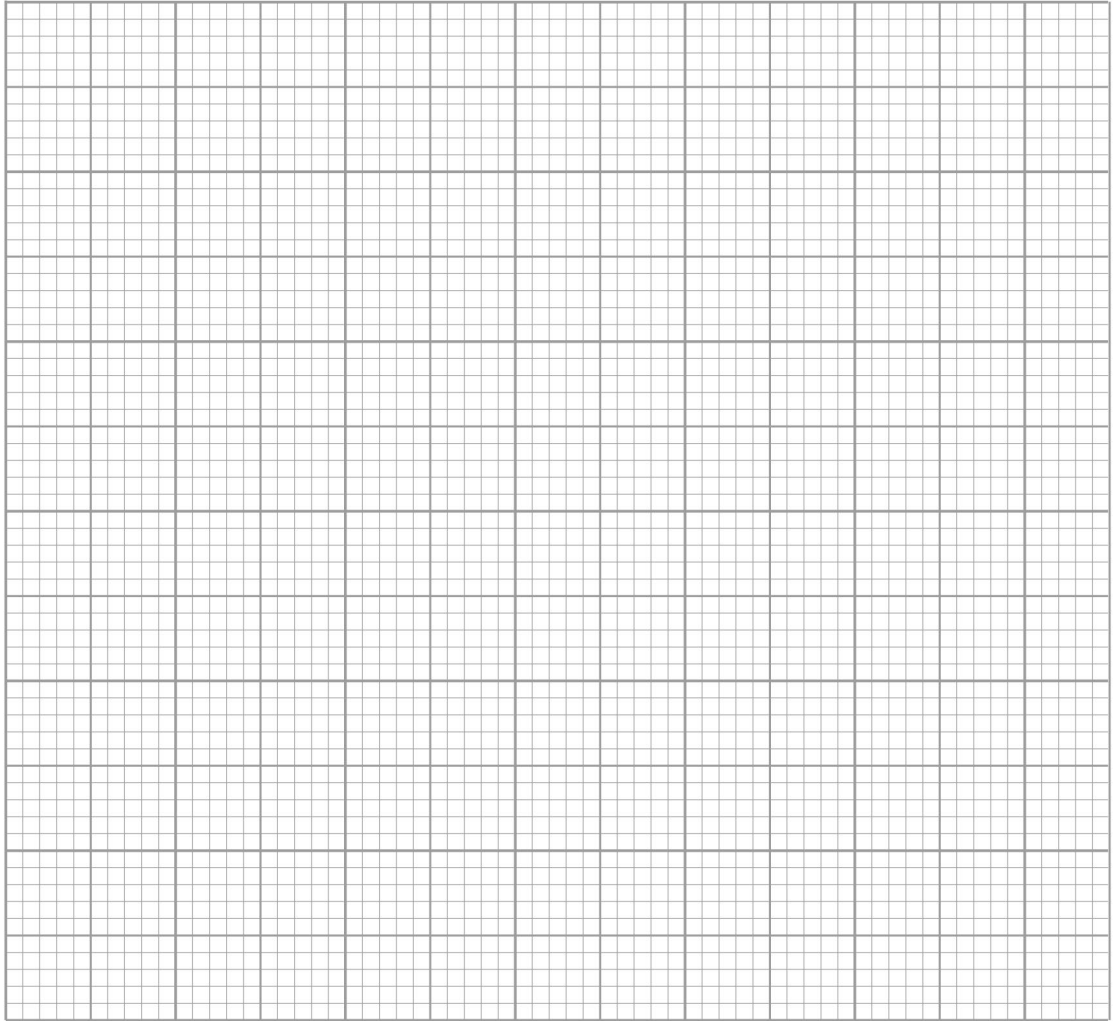

[Turn over]

13



11 PARCELS

Sam sends parcels using couriers.

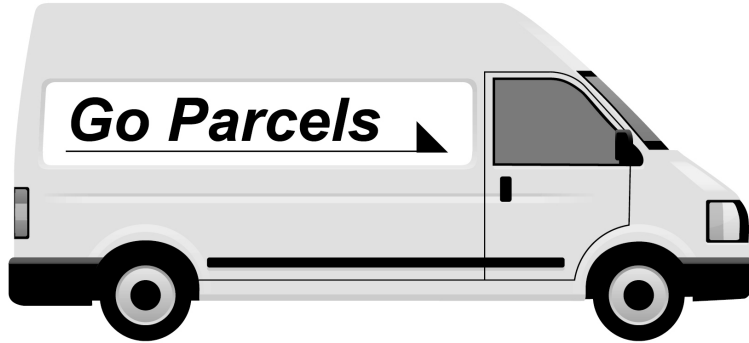

11 (a) The table shows information about the cost of sending parcels with Go Parcels.

WEIGHT RANGE		COST
Up to 1 kg		£5.99
More than	1 kg up to 10 kg	£12.99
More than	10 kg up to 15 kg	£14.24
More than	15 kg up to 20 kg	£25.49



Sam needs to send items weighing 2 kg, 4 kg and 11 kg

Sam can combine the three items into one parcel before sending.

**How much cheaper is it to send one combined parcel rather than three separate parcels?
[4 marks]**

[Turn over]



30

Answer £ _____



BLANK PAGE

[Turn over]



11 (b) Sam sends a parcel with a different courier, Package Plus.

The parcel is a cuboid box measuring 2 m by 0.4 m by 0.6 m

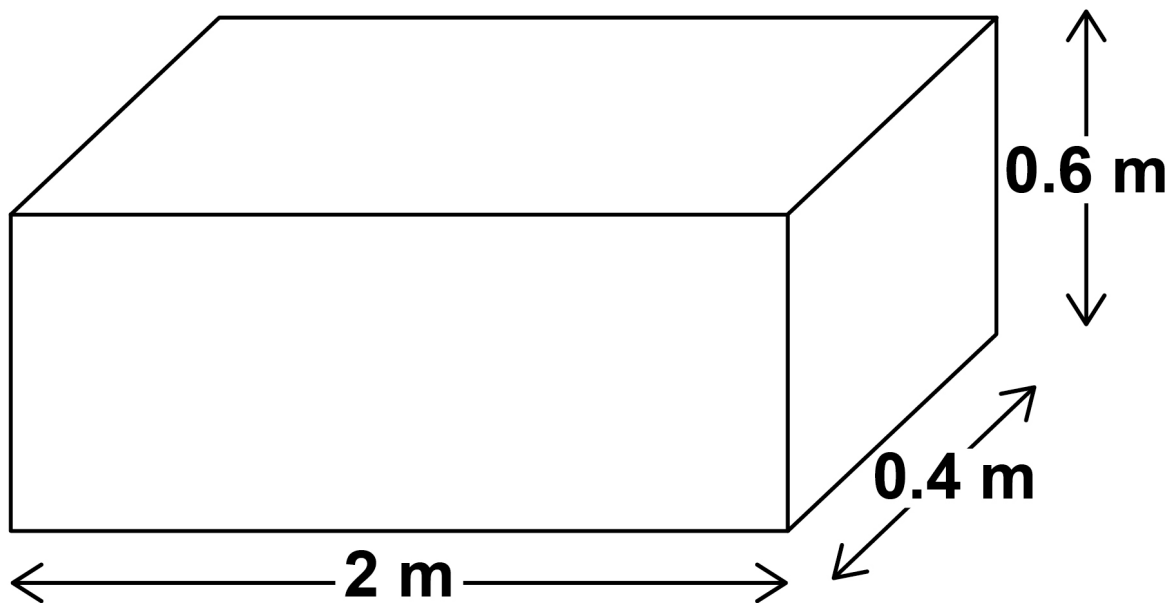

Package Plus charges using the formula

$$\text{Cost (£)} = \text{£15.25} + (\text{volume of parcel in m}^3 \times \text{£4.25})$$

Sam pays with a £20 note.



How much change should Sam receive? [5 marks]

Answer £ _____

[Turn over]

9



12 THE THEATRE

Amy is going to a theatre show in Chichester.

12 (a) Amy will travel by train to Chichester.

Amy has a railcard that gives her $\frac{1}{3}$ off the normal price of a train ticket.

The normal price of a return ticket to Chichester is £16.83

Amy says,

“My ticket will cost LESS THAN £11 if I use my railcard.”

Is Amy correct?



**You MUST show your working.
[3 marks]**

[Turn over]



12 (b) The theatre sells ice creams at the interval.

All the ice creams cost the same amount.

Amy buys herself and her two friends an ice cream each.

The total cost is £8.40

How much does it cost to buy 7 ice creams? [3 marks]

Answer £ _____

[Turn over]



12 (c) At the theatre, the show starts at 7.30 pm

The show lasts for 105 minutes plus a 20-minute interval.

At the end of the show, it will take Amy 35 minutes to get to the station.

A train leaves the station at 22.17

Can Amy catch this train?

**You MUST show your working.
[4 marks]**

12 (d) Jai works in the box office at the theatre.

The theatre has 1206 seats.

For this performance, the ratio of tickets sold to tickets not sold is 5 : 1

Jai says,

“We have sold more than 1000 tickets for this performance.”

Show that he is correct. [3 marks]

END OF QUESTIONS

<hr/>
13



Additional page, if required.

**Write the question numbers in the
left-hand margin.**



**Additional page, if required.
Write the question numbers in the
left-hand margin.**



BLANK PAGE

For Examiner's Use	
Question	Mark
1–8	
9	
10	
11	
12	
TOTAL	

Copyright information

For confidentiality purposes, all acknowledgements of third-party copyright material are published in a separate booklet. This booklet is published after each live examination series and is available for free download from www.aqa.org.uk.

Permission to reproduce all copyright material has been applied for. In some cases, efforts to contact copyright-holders may have been unsuccessful and AQA will be happy to rectify any omissions of acknowledgements. If you have any queries please contact the Copyright Team.

Copyright © 2022 AQA and its licensors. All rights reserved.

IB/M/CD/Nov22/8361/2/E2

