



Surname _____

Forename(s) _____

Centre Number _____

Candidate Number _____

Candidate Signature _____

I declare this is my own work.

Functional Skills Level 2

MATHEMATICS

Paper 2 Calculator

8362/2

Monday 15 May 2023

Afternoon

Time allowed: 1 hour 30 minutes

At the top of the page, write your surname and forename(s), your centre number, your candidate number and add your signature.

[Turn over]



MATERIALS

For this paper you must have:

- a calculator
- mathematical instruments.

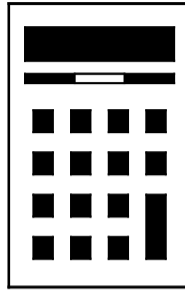
**INSTRUCTIONS**

- Use black ink or black ball-point pen. Draw diagrams in pencil.
- Answer ALL questions.
- You must answer the questions in the spaces provided. Do not write on blank pages.
- If you need extra space for your answer(s), use the lined pages at the end of this book. Write the question number against your answer(s).
- Do all rough work in this book. Cross through any work you do not want to be marked.
- State the units of your answer where appropriate.



INFORMATION

- The marks for questions are shown in brackets.
- The maximum mark for this paper is 60.
- You may ask for more answer paper, graph paper and tracing paper. These must be tagged securely to this answer book.
- If your calculator does not have a π button, take the value of π to be 3.142

ADVICE

In all calculations, show clearly how you work out your answer.

DO NOT TURN OVER UNTIL TOLD TO DO SO



SECTION A

Answer ALL questions in the spaces provided.

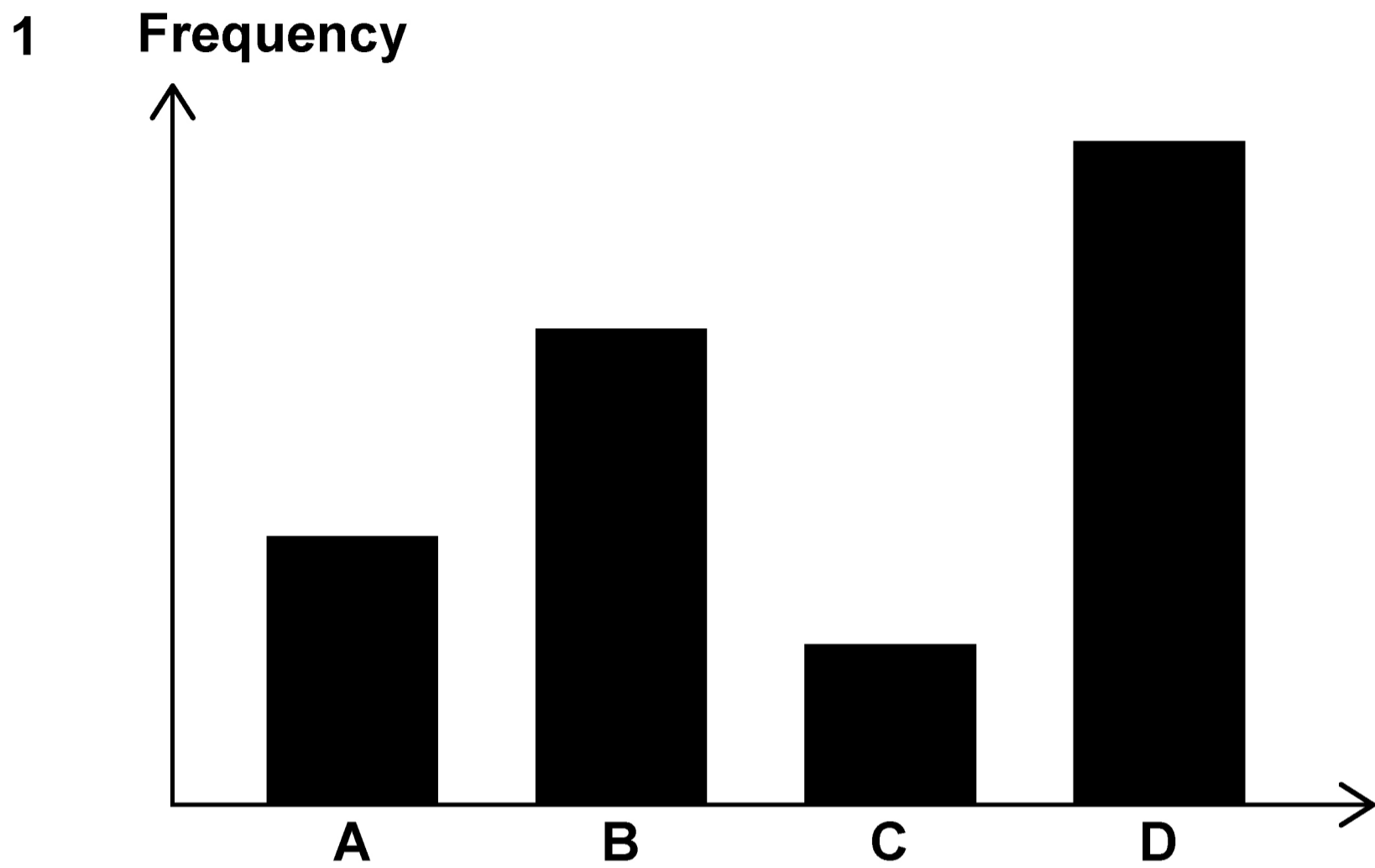

Circle the letter that is the mode. [1 mark]

A

B

C

D



- 2 Write these numbers in order, starting with the SMALLEST.
[2 marks]

0.84

0.804

0.847

0.8074

Answer

_____ , _____ , _____ , _____

[Turn over]



3 A cuboid has dimensions 2 cm by 4 cm by 5 cm

Use the centimetre isometric paper to draw a 3-D diagram of the cuboid. [2 marks]

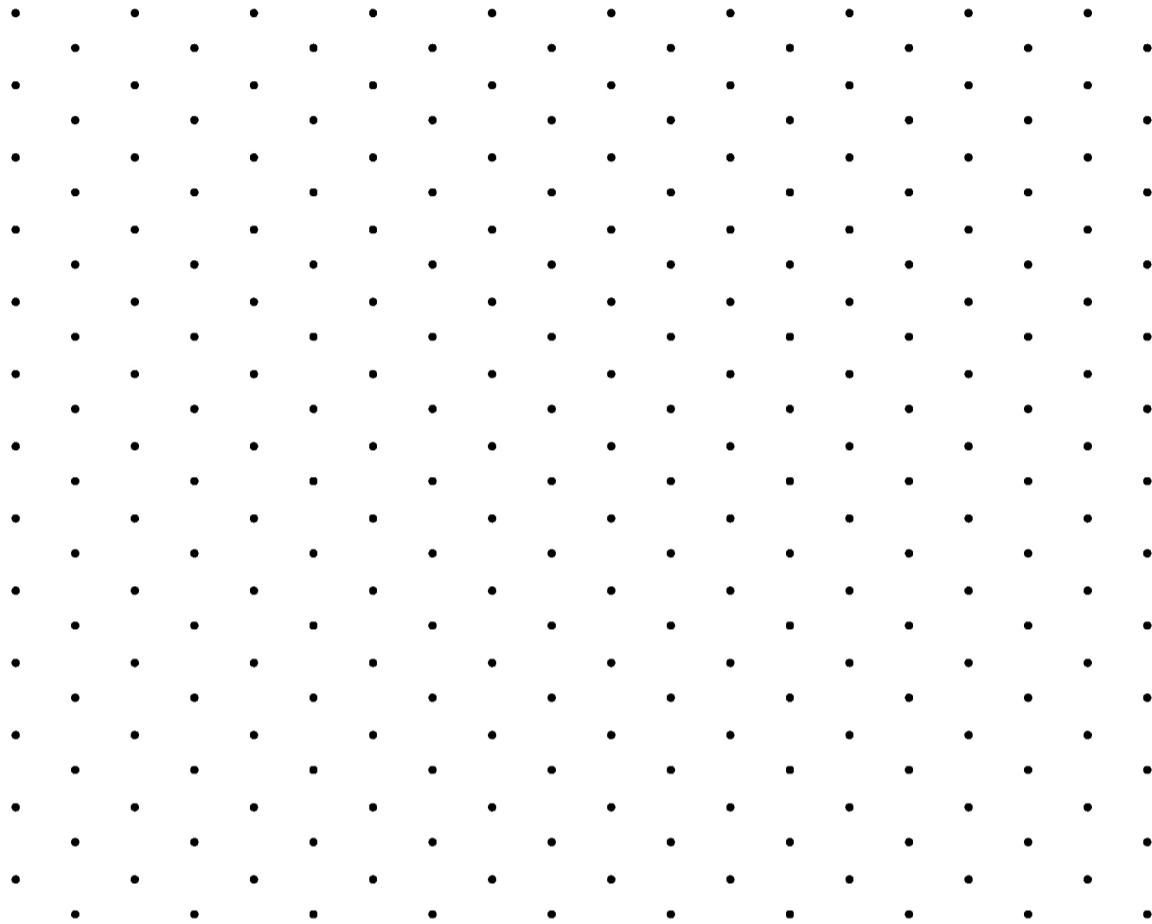

4 Write 6% as a decimal and as a fraction. [2 marks]

Decimal _____ Fraction _____

[Turn over]



- 5 The diagram is not drawn accurately.

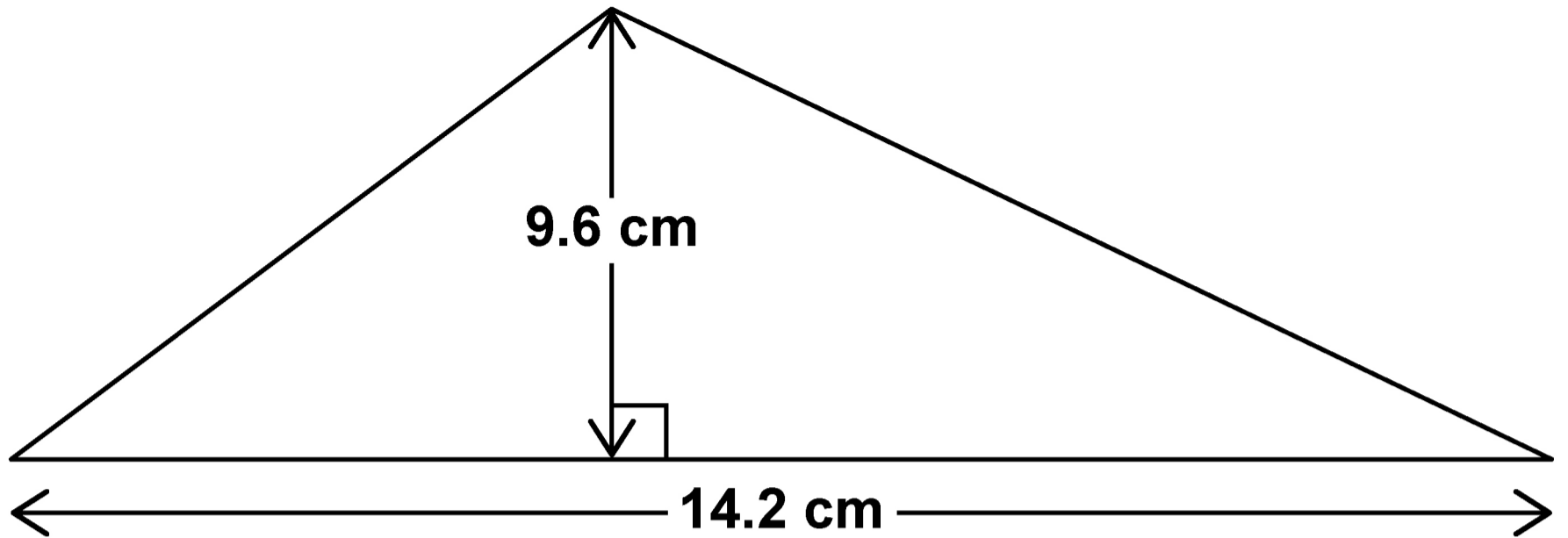

Work out the area of the triangle. [2 marks]

Answer _____ cm^2



6 Use APPROXIMATIONS to estimate $597 - (61 - 38)^2$

Do NOT calculate the exact answer.

You MUST show your working. [3 marks]

Answer _____

[Turn over]

12



SECTION B

Answer ALL questions in the spaces provided.

7 GARDEN

7(a) Oskar is going to have a barbecue in his garden.

He will buy packs of beef burgers and packs of veggie burgers.

Here are the prices.

Beef Burgers

Pack of 15

£11.23

Veggie Burgers

Pack of 2

£1.30

**Oskar needs 55 burgers in the ratio
beef : veggie = 9 : 2**

**How much will Oskar spend to buy the packs he
needs? [5 marks]**



Answer £ _____

[Turn over]



7 (b) Oskar wants to put fairy lights all around his garden.

He will use 120 cm of wire and 7 light bulbs for each metre of fence or wall.

The diagram is not drawn accurately.

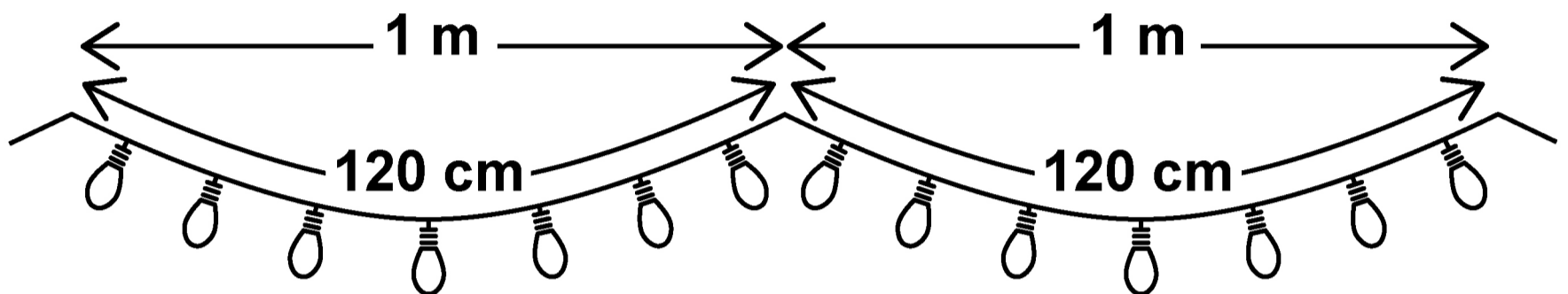

Here is a sketch of the plan of Oskar's garden.

The diagram is not drawn accurately.

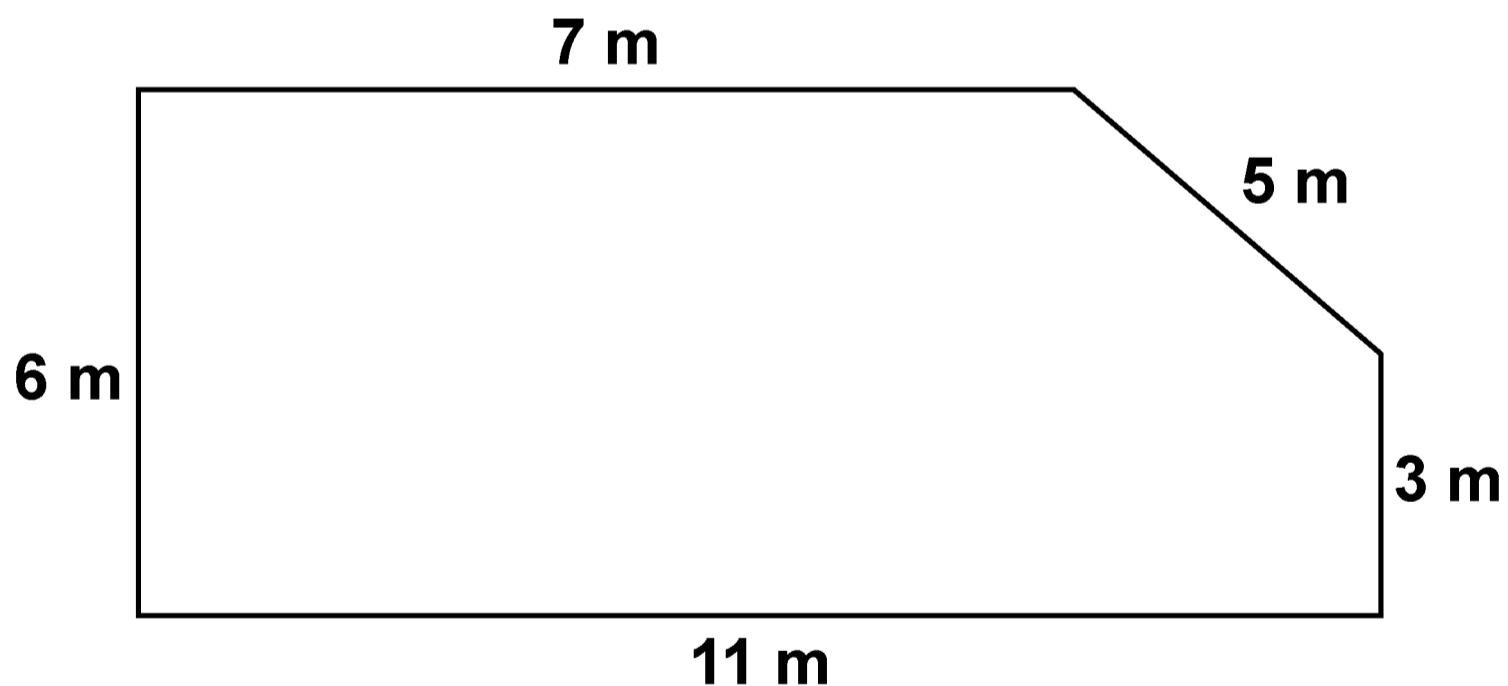

Work out the total length of wire in metres and the total number of light bulbs that Oskar needs.

[4 marks]



Wire _____ metres

Light bulbs _____

[Turn over]



7 (c) Oskar wants to buy a garden slide for his children.

He sees this sketch of a slide showing two of the angles.

The diagram is not drawn accurately.

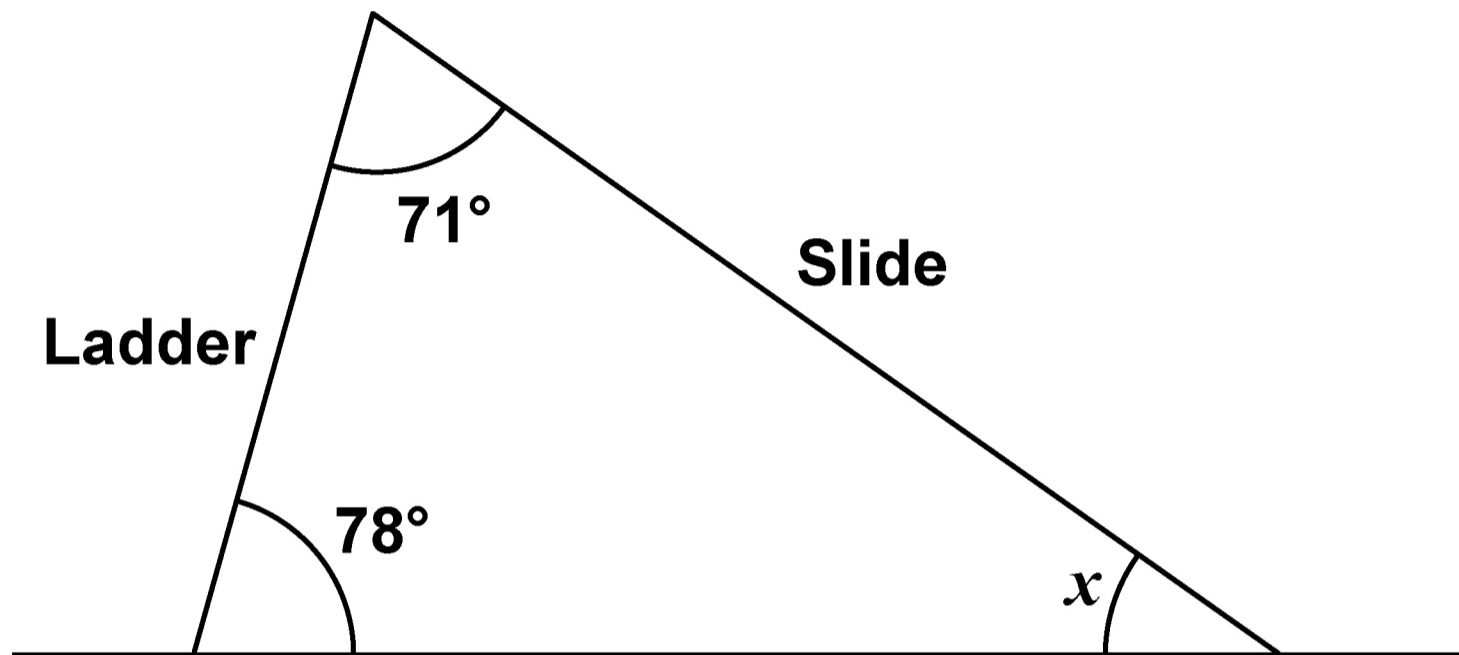

For the slide to be suitable for children, angle x should be between 28° and 32°

Is the slide suitable for children?

You **MUST** show your working. [2 marks]

[Turn over]

11



8 TOYS**8 (a) Rosie sells glass marbles.**

$$\text{Volume of a sphere} = \frac{4}{3} \pi r^3$$

Each marble is a sphere with radius 0.8 cm

The density of the glass is 2.6 g/cm³

The delivery company Rosie uses has a maximum weight of 1400 g per parcel.

Can she send 270 marbles in one parcel?

You MUST show your working. [4 marks]



[Turn over]



8 (b) Kian makes dolls' houses, based on a real house.

He uses a scale of 1 : 12

The door of the real house has a height of 78 inches.

Kian cuts the doors for the dolls' houses from a 1.1 metre length of wood.

The width of the wood is correct for the doors of the dolls' houses.

How many doors can he cut from the length of wood?

Use 1 inch = 2.5 cm

You MUST show your working. [5 marks]

Answer _____

[Turn over]

8 (c) Chris sees an advert for a child's bike.

SALE

Reduced by 25%

Now only £99

Chris says,

“The original price of the bike was MORE THAN £130”

Is he correct?

You MUST show your working. [3 marks]

[Turn over]

12



9 WEDDING MEAL

Jess organises wedding meals.

9 (a) Jess offers the following items.

Place names	£2.40 per person
Chair decorations	£1.75 per person
Tablecloths	£12 per table
Flowers (small)	£22.50 per table
Flowers (large)	£36 per table

A customer places an order for

- **place names for 72 people**
- **flowers (small) for 9 tables.**

The customer pays $\frac{1}{3}$ of the cost of these items in advance.

**Work out the amount the customer has left to pay.
[5 marks]**



9 (b) Jess has two different shaped tables to choose from.

The diagram is not drawn accurately.

Table A

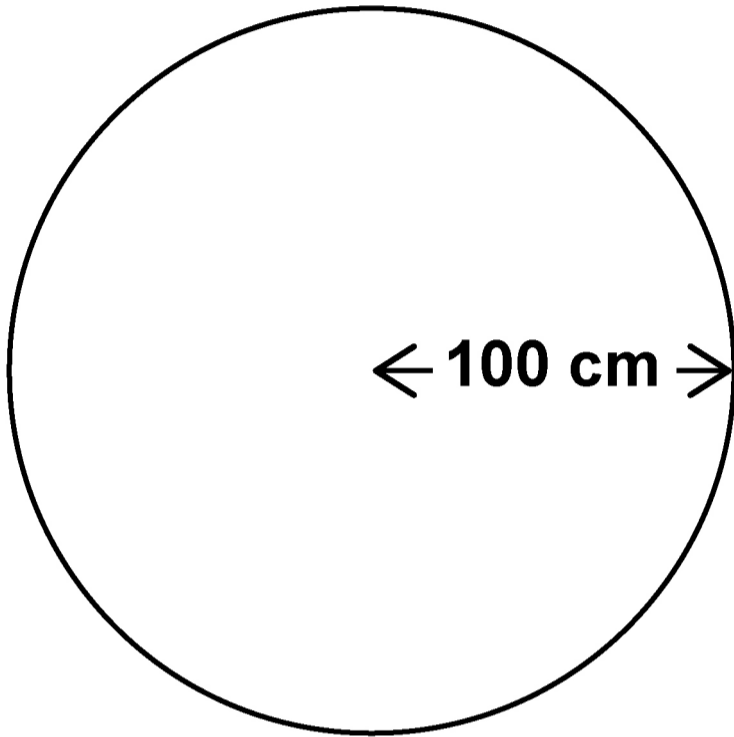

Table A

- has a top which is a circle with radius 100 cm
- sits 8 PEOPLE.



The diagram is not drawn accurately.

Table B

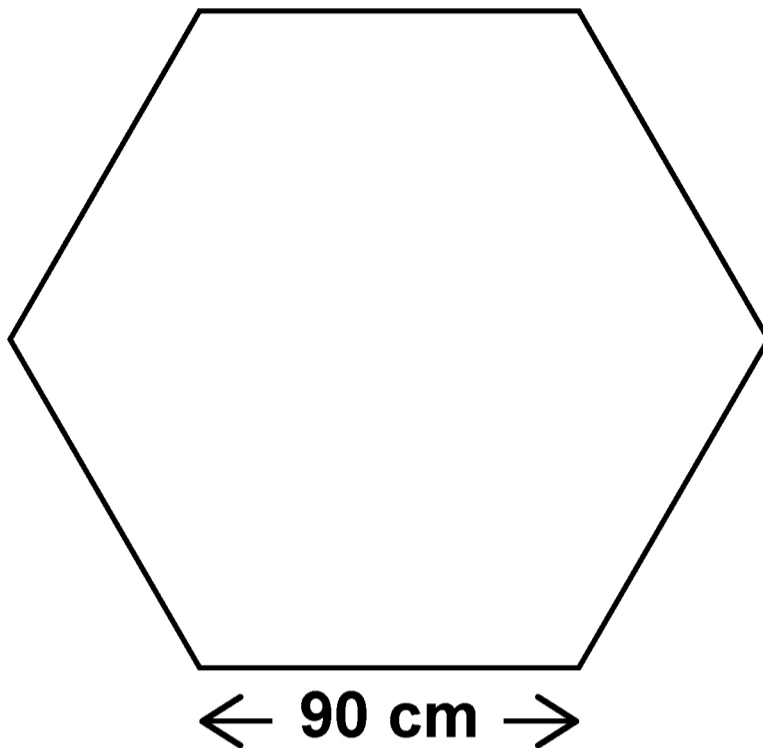

$$\text{Area of a regular hexagon} = \frac{3\sqrt{3}}{2} \times (\text{side length})^2$$

Table B

- has a top which is a regular hexagon with side length 90 cm
- sits 6 PEOPLE.

[Turn over]



BLANK PAGE



**Which table top has the larger area PER PERSON,
A or B?**

You MUST show your working. [6 marks]

[Turn over]



Answer _____

11

BLANK PAGE

[Turn over]



10 HOLIDAY PARK

Pete is the manager at a holiday park.

10 (a) The holiday park rents out caravans.

Pete records this information about the caravan bookings this week.

Number of guests per caravan	Number of caravans booked	Midpoint	
1 to 3	29		
4 to 6	35		
7 to 9	11		
	Total = 75		

The estimated mean number of guests per caravan LAST WEEK was 5.2

He says,

“The estimated mean number of guests per caravan is MORE this week than last week.”

Is he correct?

You MUST show your working. [4 marks]



[Turn over]



10 (b) There is a restaurant at the holiday park.

All guests at the restaurant have a main meal.
They can also order a starter or a pudding or both.

The table shows information about the guests' orders at the restaurant one day.

	STARTER	NO STARTER
PUDDING	46	65
NO PUDDING	20	19

One of these guests is chosen at random.

Show that the probability that they ordered a pudding but no starter is MORE THAN 0.4 [3 marks]



[Turn over]



10 (c) The restaurant staff get a pay rise.

COOKS

salary increases from £25 300 to £26 059

WAITERS

salary increases from £18 600 to £19 344

Who has the bigger **PERCENTAGE** increase in their salaries, cooks or waiters?

You **MUST** show your working. [4 marks]

Answer _____

[Turn over]



10 (d) There is an indoor play area at the holiday park.

On 11 days, the outside temperature and the number of children who used the play area were recorded.

The scatter graph, on the opposite page, represents the results.

Use the scatter graph to estimate the number of children who will use the play area when the temperature is 18°C.

You MUST show your working which should be on the graph. [3 marks]

Answer _____



Number of children

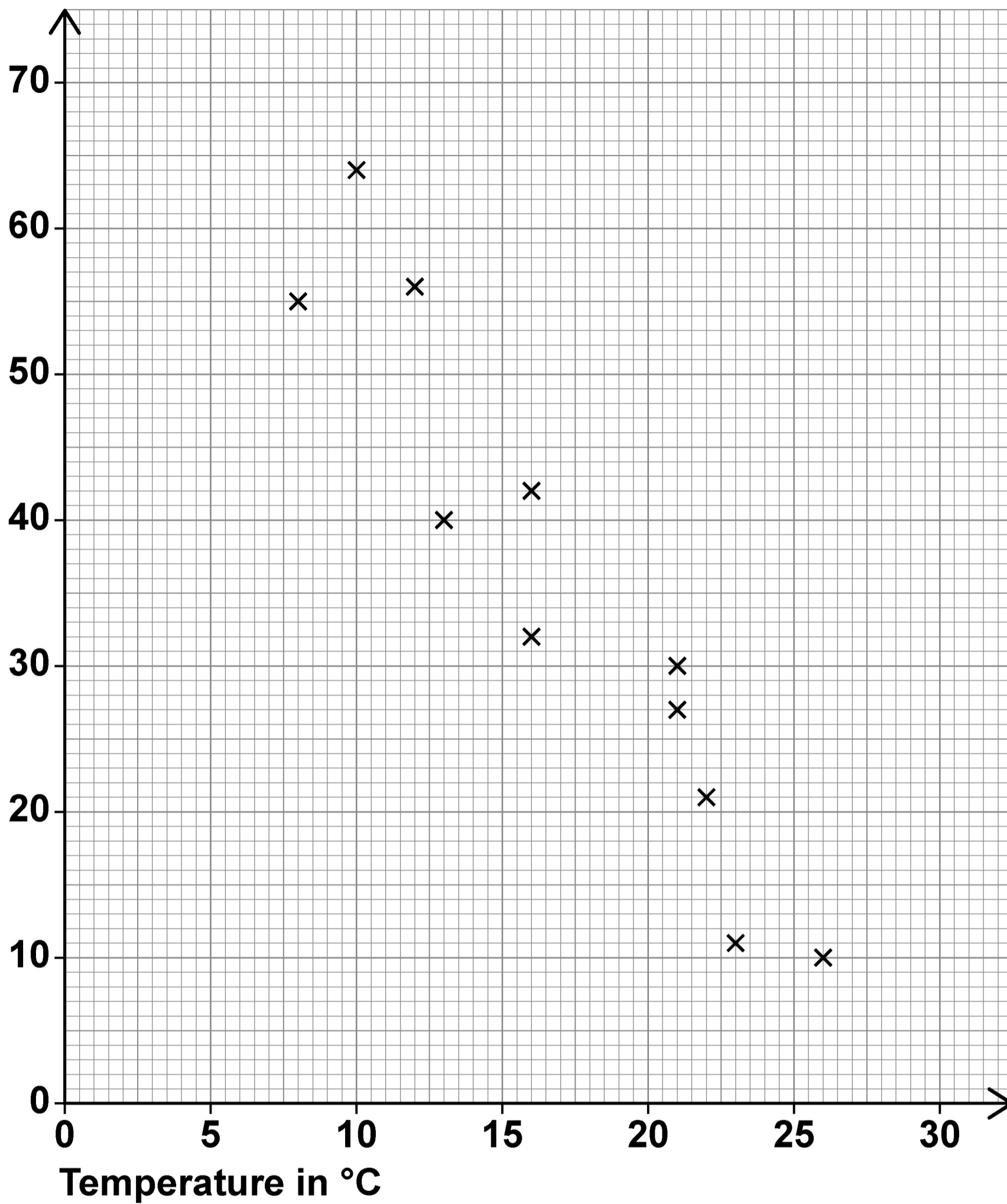

END OF QUESTIONS

14



Additional page, if required.

Write the question numbers in the left-hand margin.



Additional page, if required.

Write the question numbers in the left-hand margin.

BLANK PAGE

For Examiner's Use	
Question	Mark
1–6	
7	
8	
9	
10	
TOTAL	

Copyright information

For confidentiality purposes, all acknowledgements of third-party copyright material are published in a separate booklet. This booklet is published after each live examination series and is available for free download from www.aqa.org.uk.

Permission to reproduce all copyright material has been applied for. In some cases, efforts to contact copyright-holders may have been unsuccessful and AQA will be happy to rectify any omissions of acknowledgements. If you have any queries please contact the Copyright Team.

Copyright © 2023 AQA and its licensors. All rights reserved.

WP/M/SB/Jun23/8362/2/E2

