



Surname _____

Forename(s) _____

Centre Number _____

Candidate Number _____

Candidate Signature _____

I declare this is my own work.

GCSE

COMBINED SCIENCE: TRILOGY

Foundation Tier

Physics Paper 1F

F

8464/P/1F

Thursday 25 May 2023

Morning

Time allowed: 1 hour 15 minutes

[Turn over]



BLANK PAGE



At the front of this book, write your surname and forename(s), your centre number, your candidate number and add your signature.

MATERIALS

For this paper you must have:

- **a ruler**
- **a scientific calculator**
- **the Physics Equations Sheet (enclosed).**

[Turn over]



INSTRUCTIONS

- **Use black ink or black ball-point pen.**
- **Pencil should only be used for drawing.**
- **Answer ALL questions in the spaces provided.**
- **If you need extra space for your answer(s), use the lined pages at the end of this book. Write the question number against your answer(s).**
- **Do all rough work in this book. Cross through any work you do not want to be marked.**
- **In all calculations, show clearly how you work out your answer.**



INFORMATION

- **The maximum mark for this paper is 70.**
- **The marks for questions are shown in brackets.**
- **You are expected to use a calculator where appropriate.**
- **You are reminded of the need for good English and clear presentation in your answers.**

DO NOT TURN OVER UNTIL TOLD TO DO SO



0	1
---	---

A scientist investigated the radiation emitted by different radioactive isotopes.

The scientist had a sample of polonium-210.

The radiation emitted by polonium-210 can be represented by the symbol ${}^4_2\text{He}$.



0	1	.	1
---	---	---	---

Which type of radiation can be represented by the symbol ${}^4_2\text{He}$?

[1 mark]

Tick (✓) ONE box.

Alpha

Beta

Gamma

[Turn over]



0	1	.	2
---	---	---	---

How many protons are there in a particle of radiation represented by ${}^4_2\text{He}$?

[1 mark]

Tick (✓) ONE box.

2

4

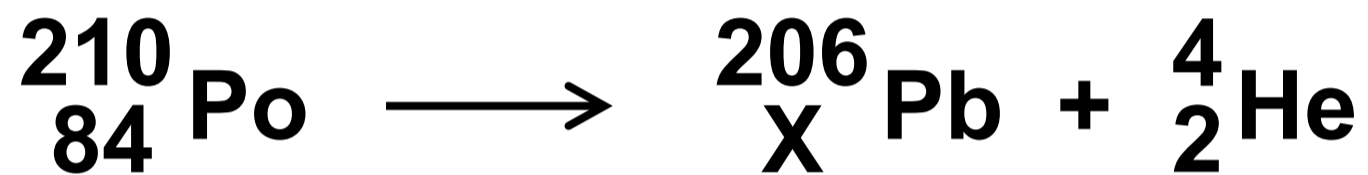
6

8



0	1	.	3
---	---	---	---

A polonium-210 (Po) nucleus changes into a lead (Pb) nucleus by emitting a ${}^4_2\text{He}$ particle. This is shown by the following nuclear equation.



What is the value of X? [1 mark]

Tick (✓) ONE box.

80

82

84

86

[Turn over]



0	1	.	4
---	---	---	---

The sample of polonium-210 had an activity of 100 Bq.

Complete the sentence.

**Choose the answer from the list.
[1 mark]**

- 25
- 50
- 100
- 200

After one half-life, the activity of polonium-210 in the sample was
_____ Bq.



The scientist investigated another radioactive isotope that is a source of gamma radiation.

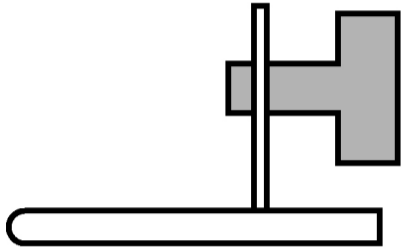
FIGURE 1, on page 12, shows the equipment used.

[Turn over]

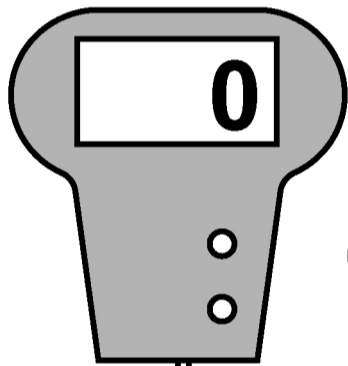


FIGURE 1

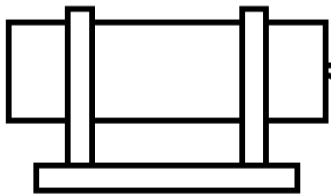
Source of gamma radiation



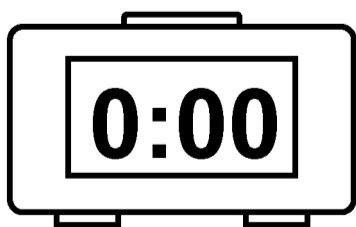
Counter



Detector



Stopwatch



0	1	.	5
---	---	---	---

The count-rate is the number of counts detected each second.

In 30 seconds the number of counts detected was 1500.

Calculate the count-rate. [2 marks]

Count-rate =

_____ counts per second

[Turn over]



The scientist placed a thick sheet of lead between the source of gamma radiation and the detector.

0 1 . 6

What was the effect of the sheet of lead on the count-rate?

Give a reason for your answer. [2 marks]

Effect _____

Reason _____



0	1	.	7
---	---	---	---

The lead was irradiated by the gamma radiation.

**What happened to the lead when it was irradiated by the gamma radiation?
[1 mark]**

Tick (✓) ONE box.

The lead atoms became radioactive.

The lead gained atoms from the radioactive source.

The lead was exposed to gamma radiation.

[Turn over]



0	1	.	8
---	---	---	---

Gamma radiation is emitted from the nucleus of an atom.

Complete the sentence.

**Choose the answer from the list.
[1 mark]**

- **electromagnetic waves**
- **high speed electrons**
- **neutrons**
- **positively charged ions**

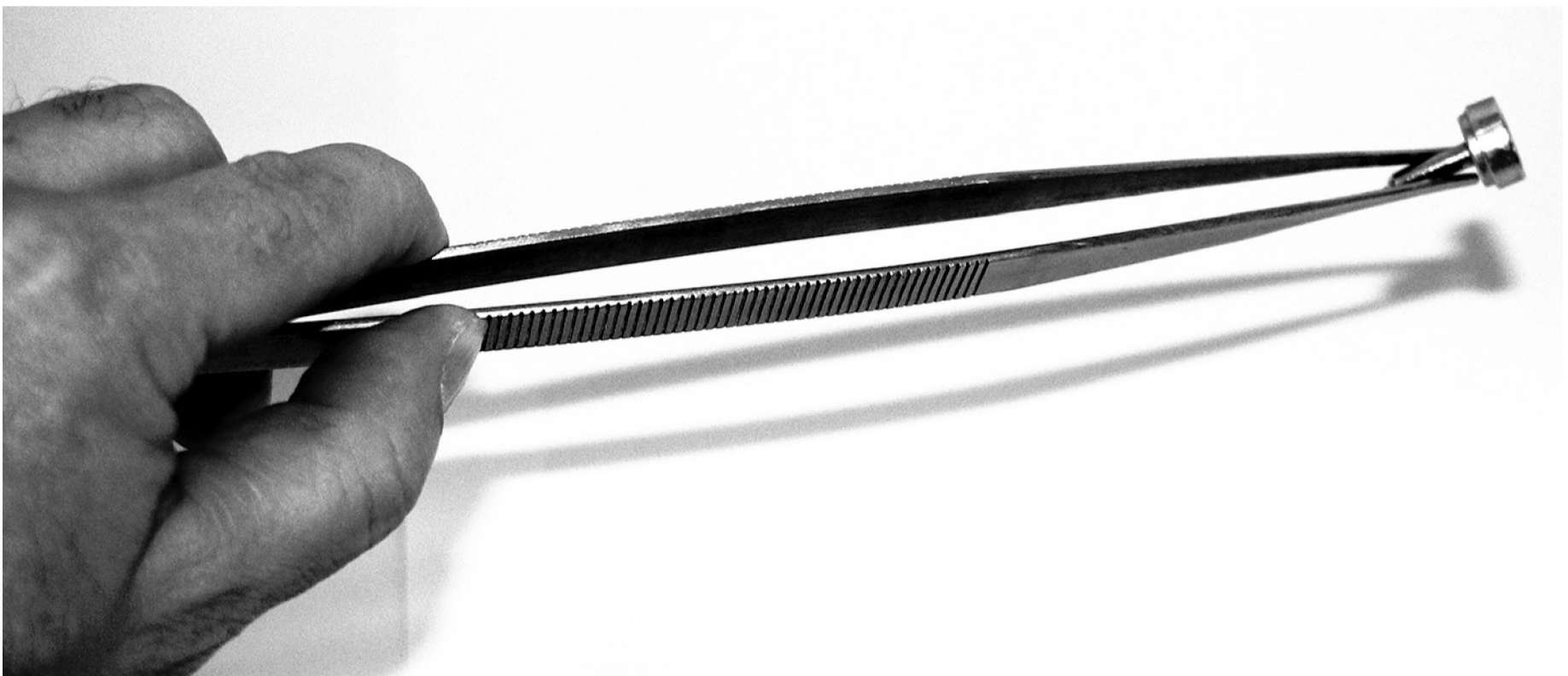
Gamma radiation consists of

_____ .



0 1 . 9

FIGURE 2 shows the scientist holding the radioactive source using tongs.

FIGURE 2

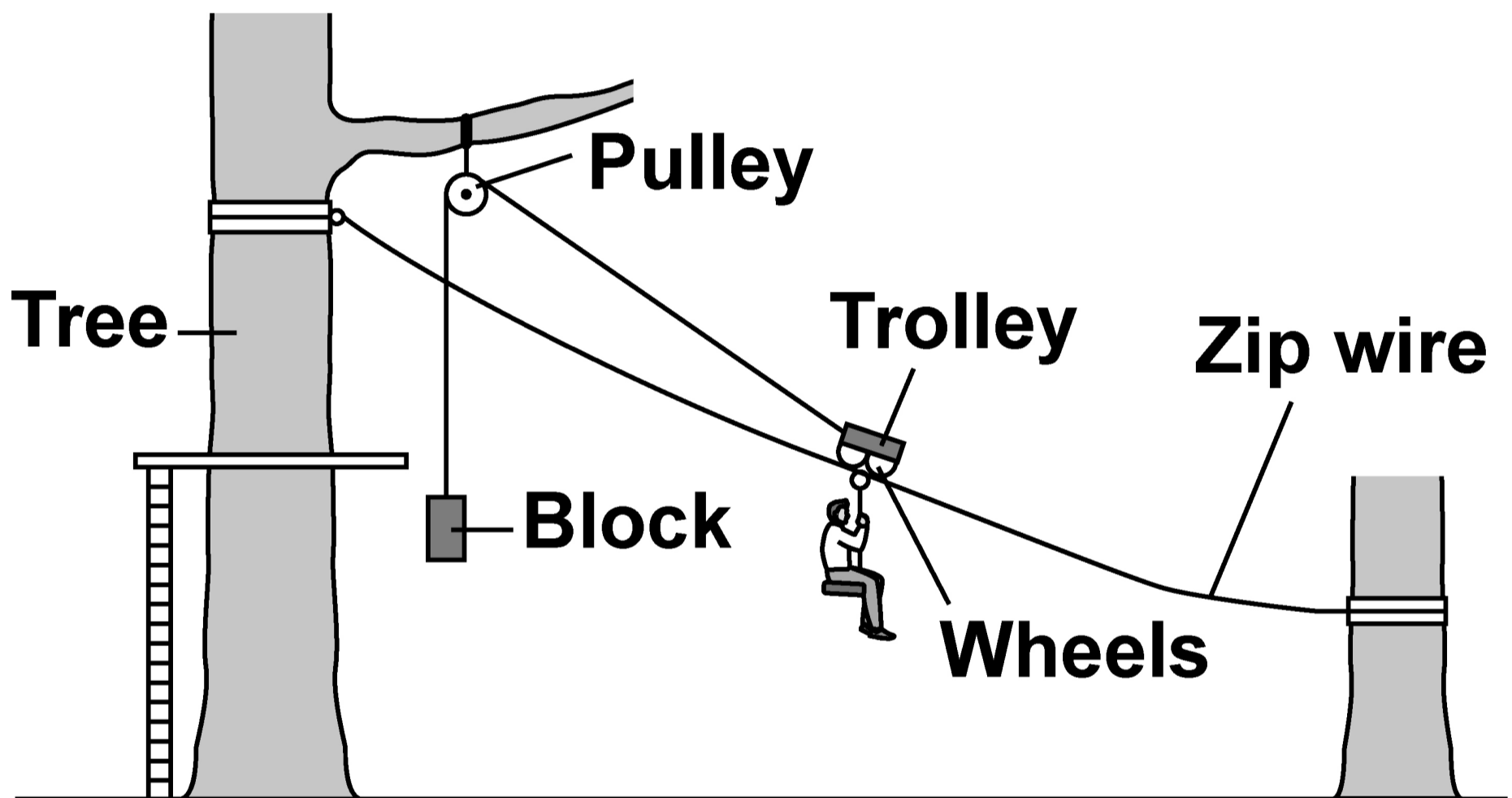
Suggest ONE reason why using long tongs rather than short tongs was safer for the scientist. [1 mark]

[Turn over]**11**

0 2

FIGURE 3 shows a person using a zip wire to move from a tree to the ground.

FIGURE 3



As the person moves down the zip wire, the block moves upwards.

0 2 . 1

**What happens to the gravitational potential energy of the person as the person accelerates down the zip wire?
[1 mark]**

Tick (✓) ONE box.

Decreases

Stays the same

Increases

[Turn over]



0 2 . 2

What happens to the kinetic energy of the person as the person accelerates down the zip wire? [1 mark]

Tick (✓) ONE box.

Decreases

Stays the same

Increases



BLANK PAGE

[Turn over]



0 2 . 3

The block is 3.4 m above the ground when the person is at the bottom of the zip wire.

mass of block = 2.5 kg

gravitational field strength = 9.8 N/kg

Calculate the gravitational potential energy of the block.

Use the equation:

**gravitational potential energy =
mass × gravitational field strength × height**

[2 marks]



Gravitational potential energy =

J

[Turn over]



The trolley is a seat suspended from wheels which can roll along the zip wire.

0 2 . 4

When the person reaches the end of the zip wire, the person gets off the trolley.

The block falls downwards pulling the trolley back to the top of the zip wire.

maximum speed of block = 4.8 m/s

mass of block = 2.5 kg

Calculate the maximum kinetic energy of the block.

Use the equation:

kinetic energy = $0.5 \times \text{mass} \times (\text{speed})^2$

[2 marks]



Maximum kinetic energy =

_____ **J**

[Turn over]



0	2	.	5
---	---	---	---

As the trolley moves, work is done against friction.

What is the effect of this? [1 mark]

Tick (✓) ONE box.

Some energy is destroyed.

Some energy is transferred to the surroundings.

The total energy of the block and trolley increases.



0 2 . 6

The person oils the wheels on the trolley.

Explain how this will affect the speed of the person down the zip wire. [2 marks]

9

[Turn over]





03

A piece of steel is heated until it has all melted.

03.1

Calculate the change in thermal energy when the temperature of the piece of steel is increased by 50 °C.

28

mass of steel = 4.0 kg

specific heat capacity of steel = 420 J/kg °C



Use the equation:

**change in thermal energy =
mass × specific heat capacity × temperature change**

[2 marks]

29

Change in thermal energy = _____ J

[Turn over]

0	3	.	2
---	---	---	---

The internal energy of the steel increases as the steel is heated.

What is meant by ‘internal energy of the steel’? [1 mark]

Tick (✓) ONE box.

The change in energy of the steel particles as the steel melts.

The energy added to the steel particles as they are heated.

The total kinetic energy and potential energy of the steel particles.



0	3	.	3
---	---	---	---

Solid steel cannot be poured.

Which statement about the particles in a solid gives the reason why? [1 mark]

Tick (✓) ONE box.

The number of particles always stays the same.

The particles are close together.

The particles are in fixed positions.

The particles have a fixed size.

[Turn over]



0	3	.	4
---	---	---	---

Complete the sentence.

Choose the answer from the list.

- **decreases**
- **stays the same**
- **increases**

[1 mark]

As the piece of solid steel melts, the mass of the steel _____.



BLANK PAGE

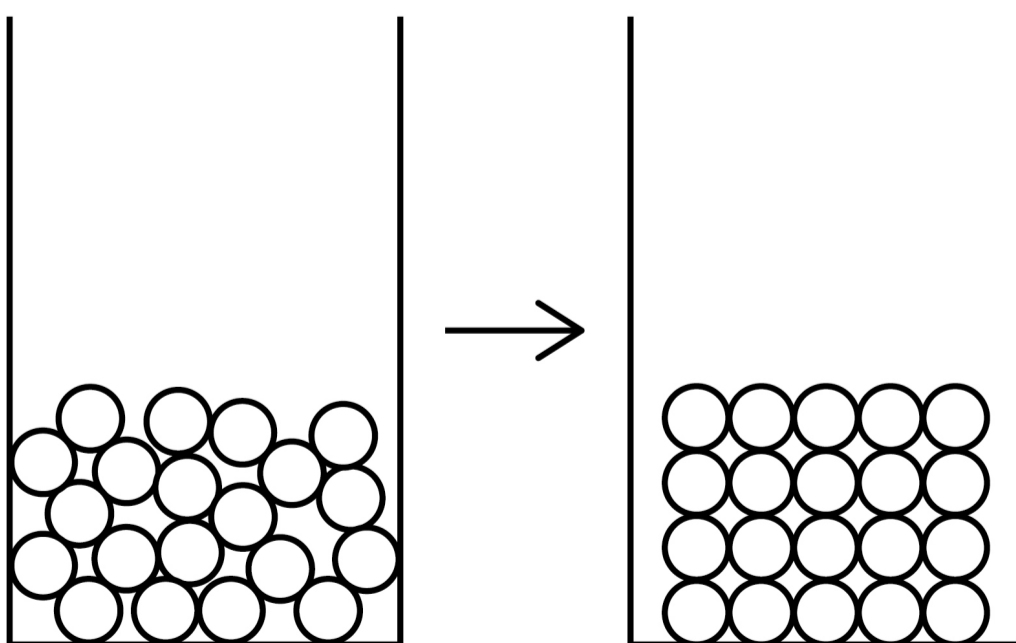
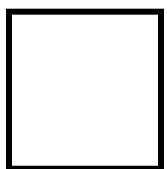
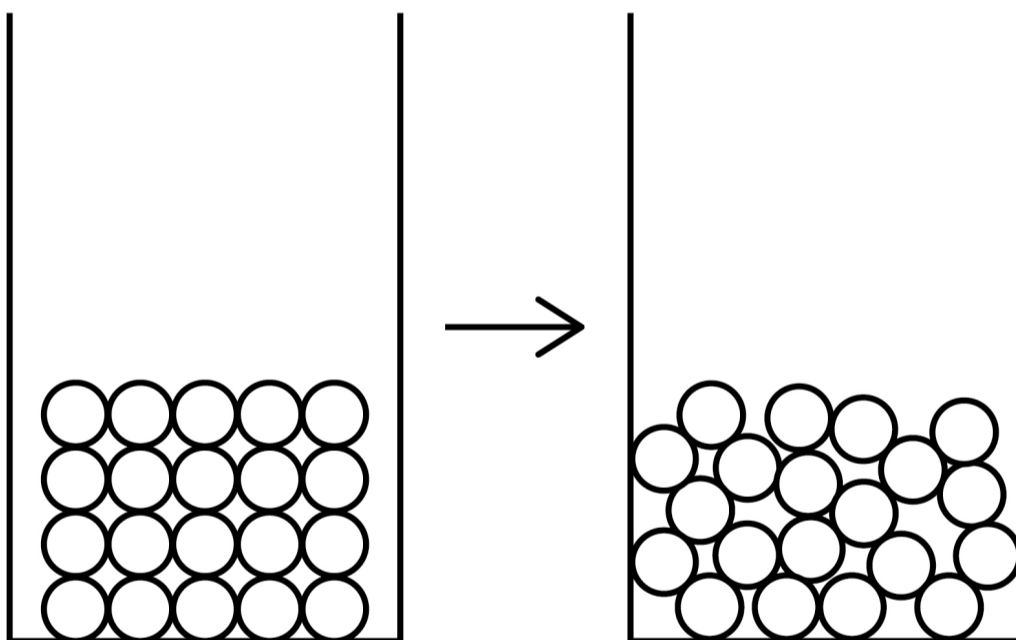
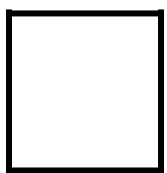
[Turn over]

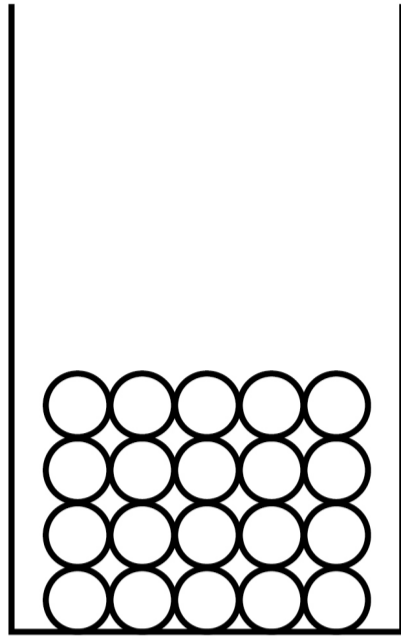
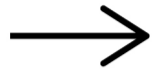
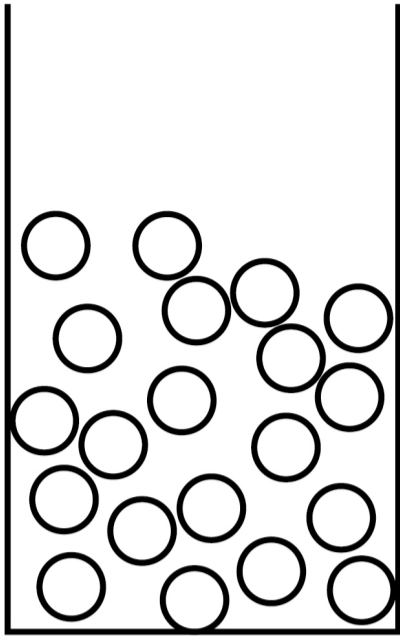
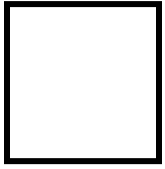


0	3	.	5
---	---	---	---

Which diagram, below and on the opposite page, shows how the arrangement of particles changes when a solid melts and becomes a liquid?
[1 mark]

Tick (✓) ONE box.





[Turn over]

03.6

The density of steel decreases as it melts.

How does the spacing of the particles change as the steel melts? [1 mark]

0	3	.	7
---	---	---	---

Complete the sentence.

Choose the answer from the list.

- **chemical**
- **permanent**
- **physical**

[1 mark]

**Melting is an example of a
_____ change.**

[Turn over]



03.8

Steel is a mixture of iron and a small amount of carbon.

TABLE 1 shows the mass of carbon in 1.0 kg of different types of steel.

TABLE 1

Type of steel	Mass of carbon in 1.0 kg of steel
Low carbon	2.0 g
Medium carbon	4.5 g
High carbon	7.0 g

A 4.0 kg piece of steel contains 18 grams of carbon.

Determine which type of steel the 4.0 kg piece is made from.

You should include a calculation in your answer. [3 marks]

Type of steel _____

[Turn over]



0	3	.	9
---	---	---	---

The 4.0 kg piece of solid steel was heated until it reached its melting point.

The additional energy required to melt the piece of steel was 280 000 J.

Calculate the specific latent heat of fusion of the steel.

**Use the Physics Equations Sheet.
[3 marks]**



Specific latent heat of fusion of steel =
_____ **J/kg**

[Turn over]

14



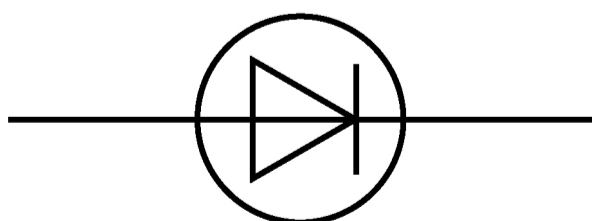
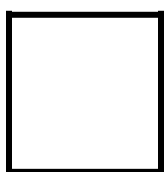
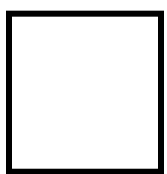
04

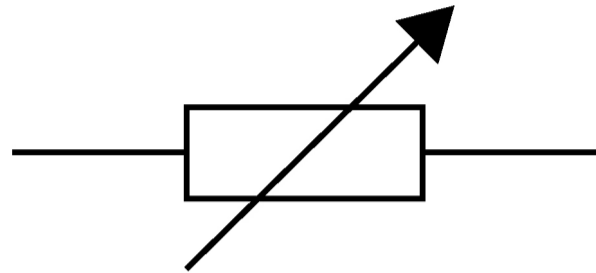
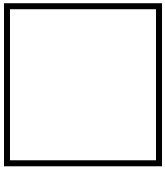
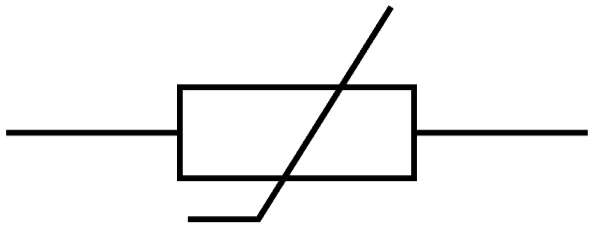
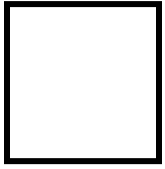
A gardener wanted to build an electrical circuit to monitor the temperature in a greenhouse.

04.1

**Which symbol, below and on the opposite page, represents an electrical component with a resistance that decreases as its temperature increases?
[1 mark]**

Tick (✓) ONE box.





[Turn over]



04.2

When the resistance of an electrical circuit decreases, the current in the circuit increases.

Complete the sentence.

Choose the answer from the list.

- **charge**
- **energy**
- **potential difference**
- **power**

[1 mark]

Electrical current is a flow of

_____ .



04.3

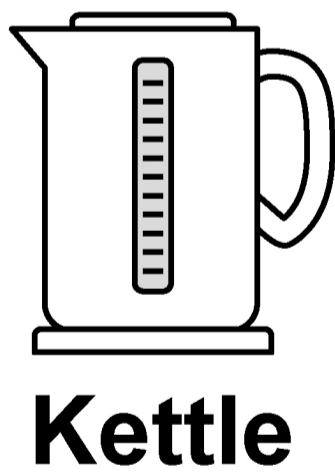
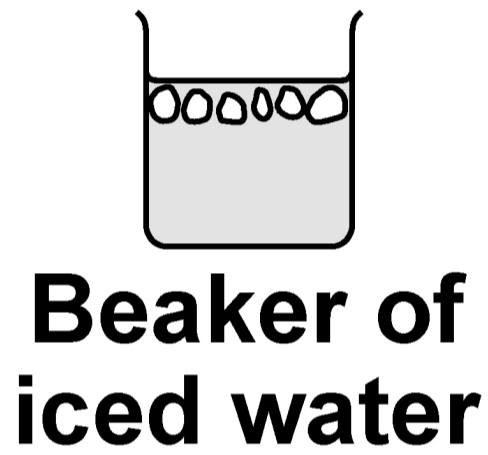
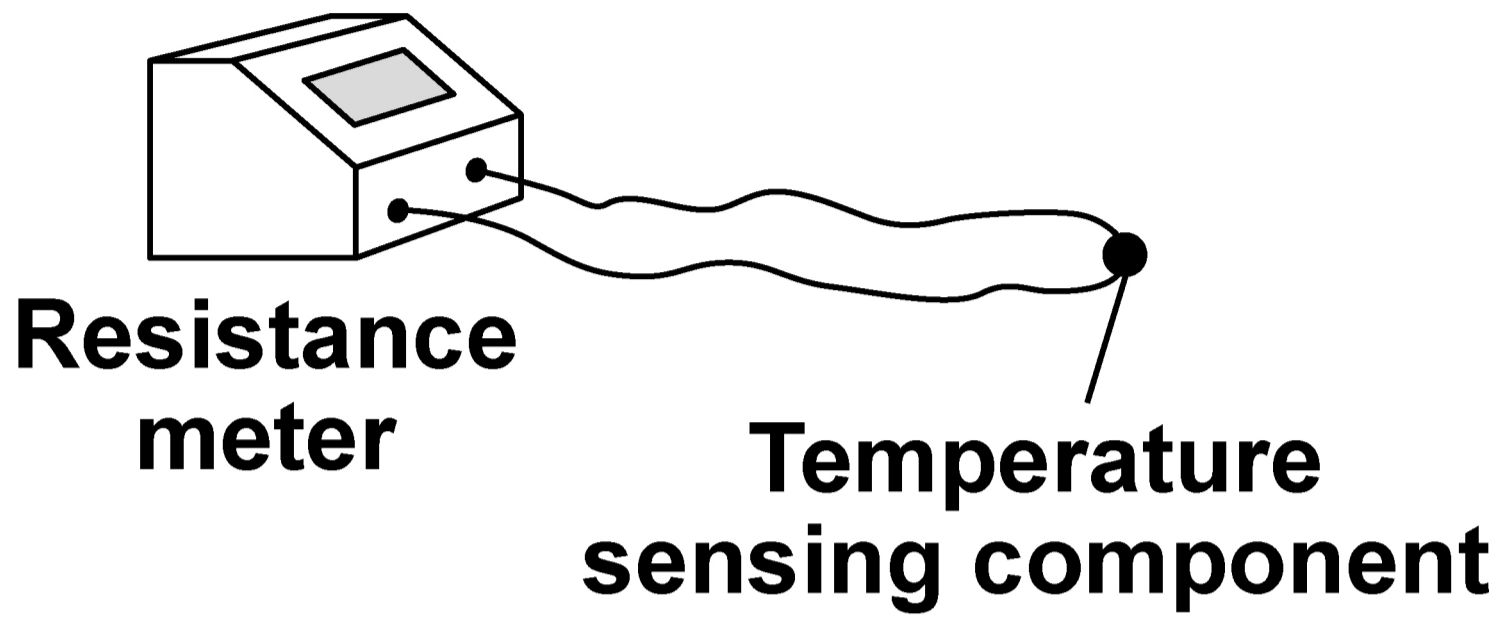
The gardener wanted to find how the resistance of the component varies with temperature.

FIGURE 4, on page 46, shows the equipment used by the gardener.

[Turn over]



FIGURE 4



The resistance meter displays the resistance of the component.

Plan a method the gardener could use to find how the resistance of the component varies with temperature.

[4 marks]

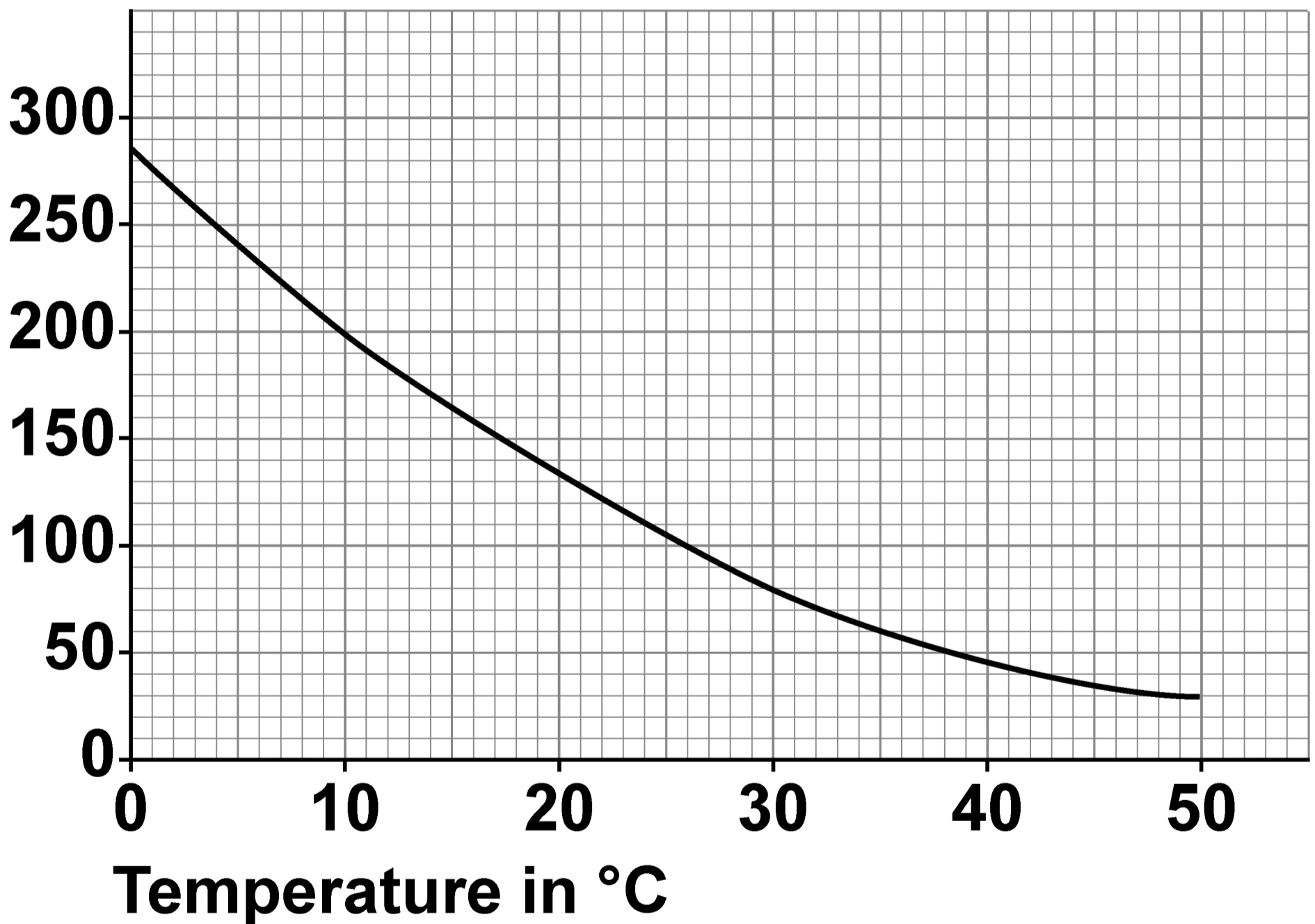
[Turn over]



FIGURE 5 shows how the resistance of the component varies with temperature.

FIGURE 5

**Resistance
in ohms**



04.4**Complete the sentence.****Choose the answer from the list.**

- **linear**
- **non-linear**
- **directly proportional**

[1 mark]

The relationship between the temperature and the resistance of the component is _____.

[Turn over]

0	4	.	5
---	---	---	---

The temperature in the greenhouse changed from 10 °C to 30 °C.

Determine the change in resistance of the component between these temperatures.

Use FIGURE 5, on page 48. [2 marks]

Change in resistance = _____ Ω



The gardener builds a circuit that switches a heater on when the greenhouse gets too cold.

Use the Physics Equations Sheet to answer questions 04.6 and 04.7.

04.6

Write down the equation that links current (I), potential difference (V) and power (P). [1 mark]

[Turn over]



0	4	.	7
---	---	---	---

The power of the heater is 2900 W.

The potential difference across the heater is 230 V.

Calculate the current in the heater.
[3 marks]

Current = _____ A

13



0	5
---	---

Wind power and solar power are both renewable energy resources used to generate electricity for the National Grid.

0	5	.	1
---	---	---	---

Which of the following is also a renewable energy resource? [1 mark]

Tick (✓) ONE box.

Geothermal

Natural gas

Nuclear fuel

[Turn over]



0	5	.	2
---	---	---	---

The energy transferred by the National Grid in one second was 36 gigajoules (GJ).

Which of the following is the same as 36 gigajoules? [1 mark]

Tick (✓) ONE box.

$36 \times 10^3 \text{ J}$

$36 \times 10^6 \text{ J}$

$36 \times 10^9 \text{ J}$

$36 \times 10^{12} \text{ J}$



BLANK PAGE

[Turn over]



05.3

FIGURE 6, on the opposite page, shows how the mean power output from solar and wind energy resources in the UK varied between 2014 and 2019.



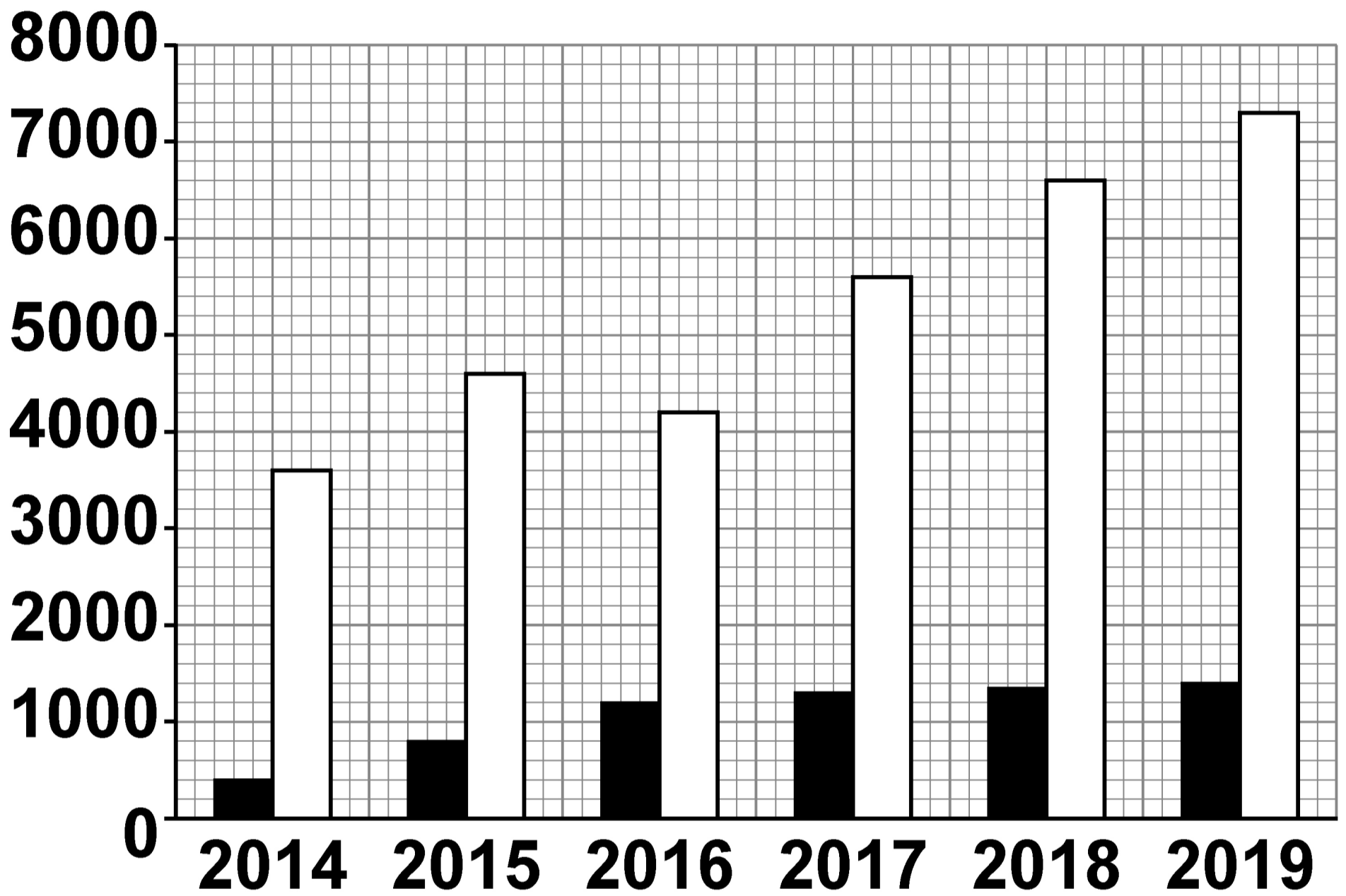
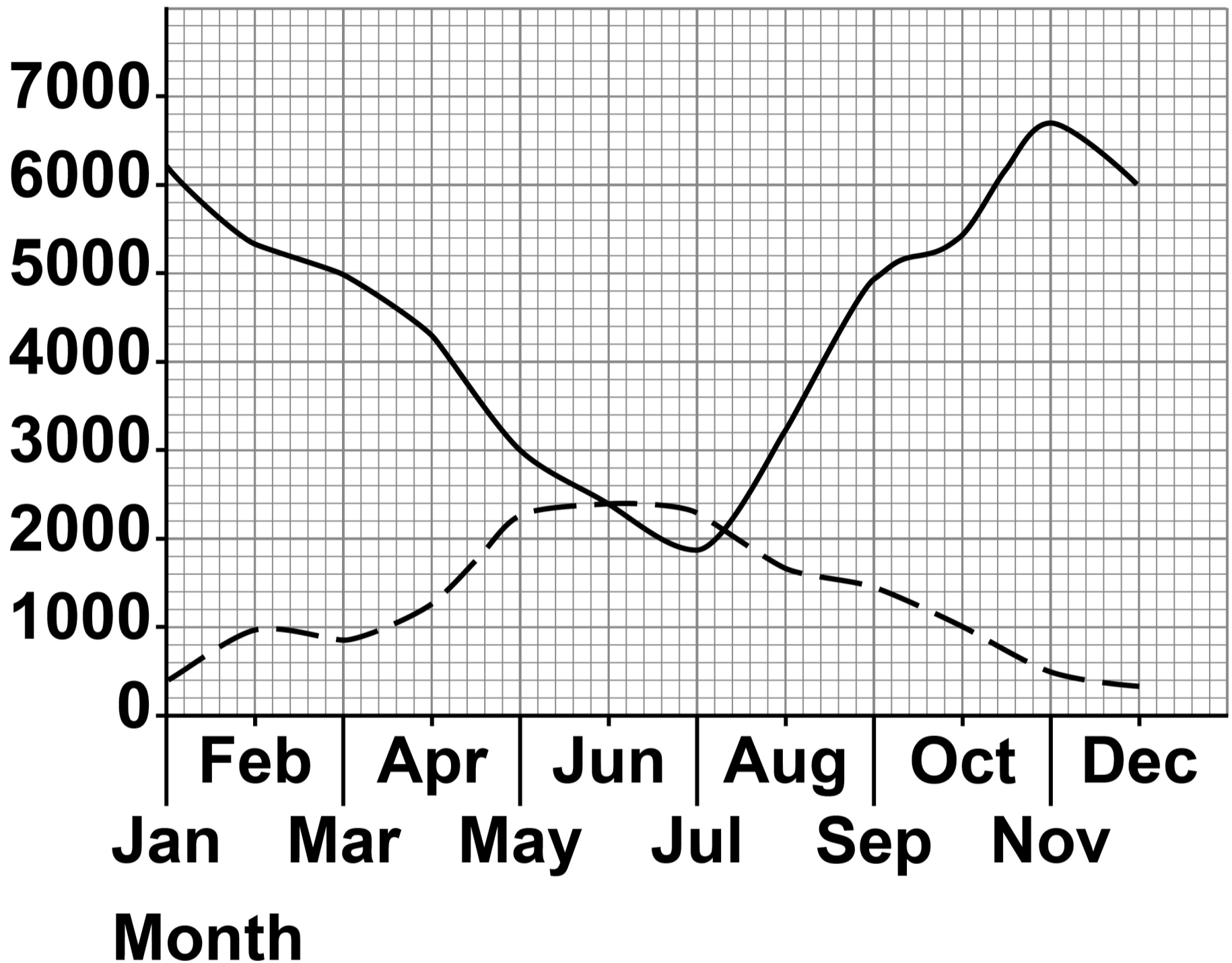
FIGURE 6**Mean power
output in MW****Year****KEY****■ Solar power****□ Wind power****[Turn over]**

FIGURE 7, on the opposite page, shows how the power output from solar and wind energy resources varies in a typical year.



FIGURE 7

Power output in MW



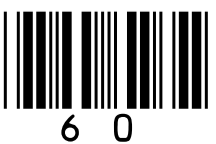
KEY

- Wind power
- - Solar power

[Turn over]



BLANK PAGE



Explain the changes in power output from solar and wind energy resources between 2014 and 2019.

You should include an explanation of the change in power output during a typical year. [6 marks]

[Turn over]





6 2

06

Body analysis scales use the electrical resistance of a person's legs to estimate the percentage of water in the person's body.

FIGURE 8 shows body analysis scales.

FIGURE 8



[Turn over]



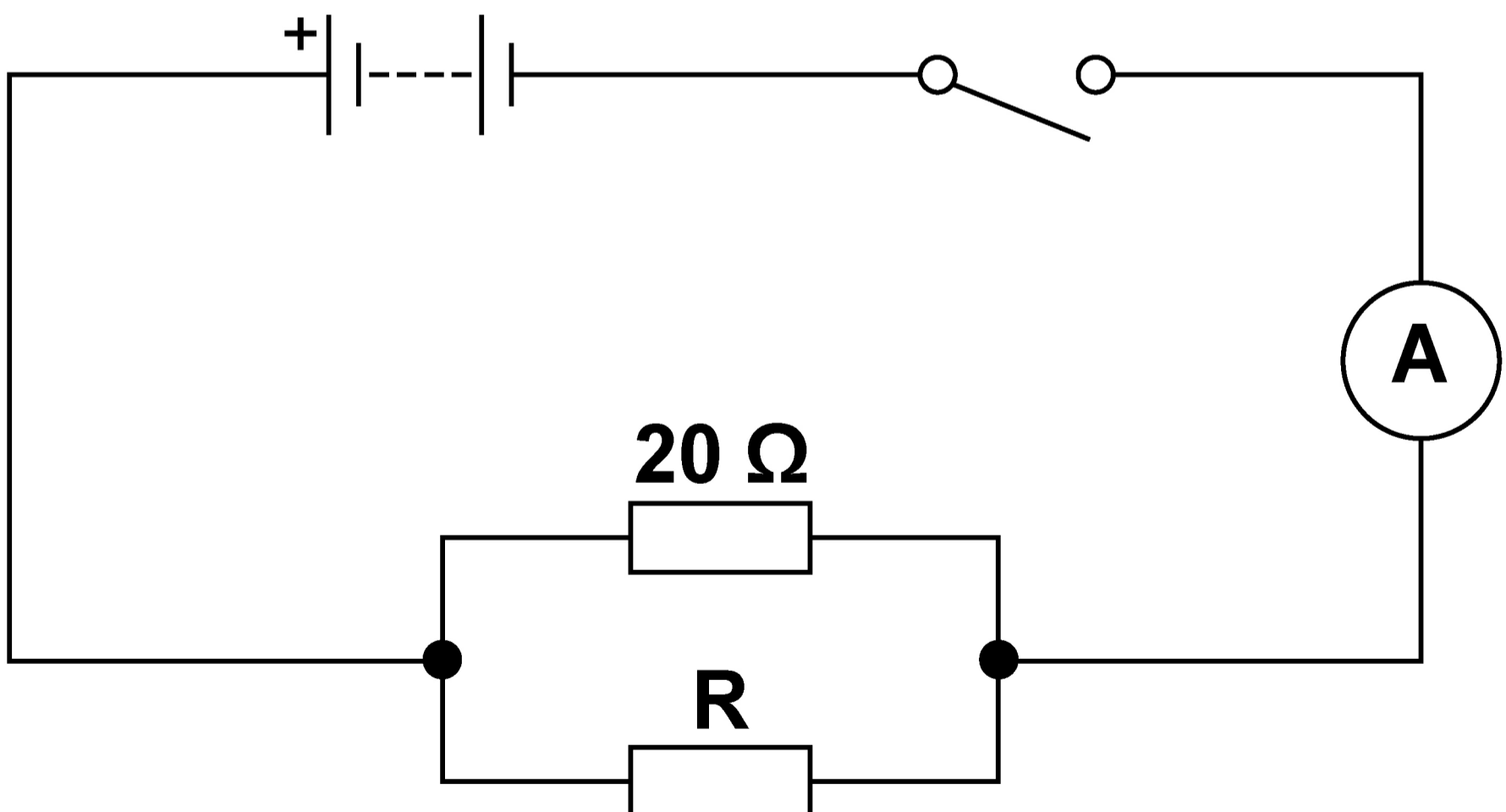
The person's legs contain both solid tissue and water.

A student used resistors to model the solid tissue and water.

The student connected a $20\ \Omega$ resistor in parallel with a resistor, R .

FIGURE 9 shows the circuit diagram.

FIGURE 9



0	6	.	1
---	---	---	---

To determine the total resistance of both resistors, a voltmeter must be connected into the circuit.

Complete FIGURE 9 to show where the voltmeter should be connected. [1 mark]

[Turn over]



06.2

The student calculated the total resistance of the two resistors.

The student's answer was 26 Ω .

Explain why the student's answer CANNOT be correct. [2 marks]

Use the Physics Equations Sheet to answer questions 06.3 and 06.4.

0 6 . 3

Write down the equation that links current (I), resistance (R) and potential difference (V). [1 mark]

[Turn over]



0	6	.	4
---	---	---	---

When the total resistance of the resistors was 7.5Ω the current in the circuit was 480 mA.

Calculate the potential difference across the two resistors. [3 marks]

Potential difference = _____ V



BLANK PAGE

[Turn over]



The student investigated how the resistance of R affected the total resistance of the circuit.

TABLE 2 shows the results.

TABLE 2

Resistance of R in ohms	Total resistance of the circuit in ohms
5.0	4.0
10.0	6.7
15.0	8.6
20.0	10.0
25.0	11.1

Some of the results are plotted in FIGURE 10, on page 72.

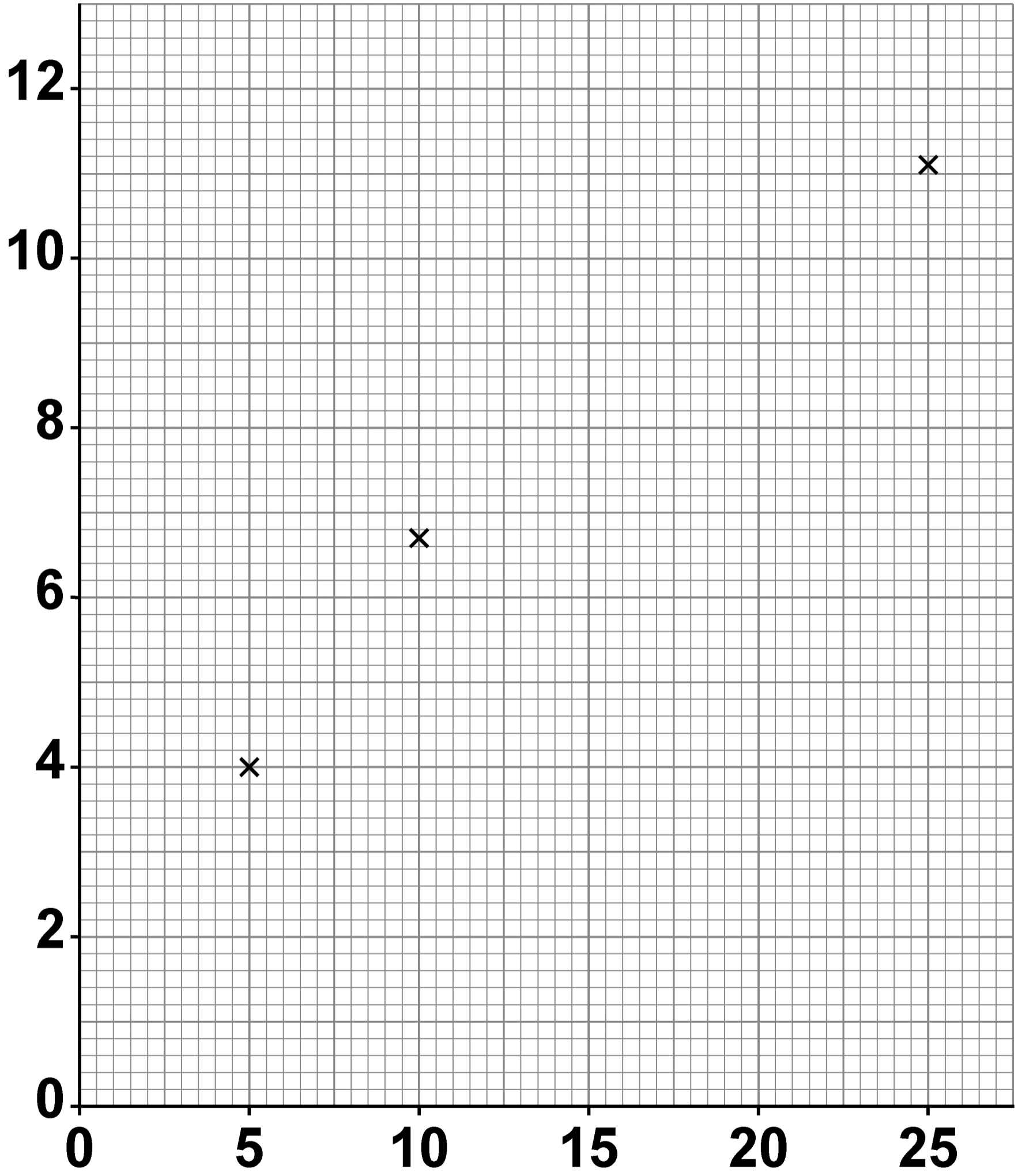


BLANK PAGE

[Turn over]



FIGURE 10



0	6	.	5
---	---	---	---

Complete FIGURE 10.

You should:

- **label both axes**
- **plot the two remaining values from TABLE 2, on page 70.**
- **draw the line of best fit.**

[3 marks]

0	6	.	6
---	---	---	---

What resistance of R would give a total resistance of 4.4Ω ?

Use FIGURE 10. [1 mark]

Resistance of R = _____ Ω

[Turn over]



The body analysis scales initially show a reading of 0.0 kg.

When the student steps onto the scales the reading is 64.8 kg.

The student steps off the scales and then immediately steps back on.

The scales now show a reading of 64.1 kg.

0 6 . 7

Complete the sentence. [1 mark]

The difference between the two values given by the scales is due to a _____ error.



06.8

The height of the student is programmed into the scales.

The scales place the student into a category, A, B or C, based on height and mass.

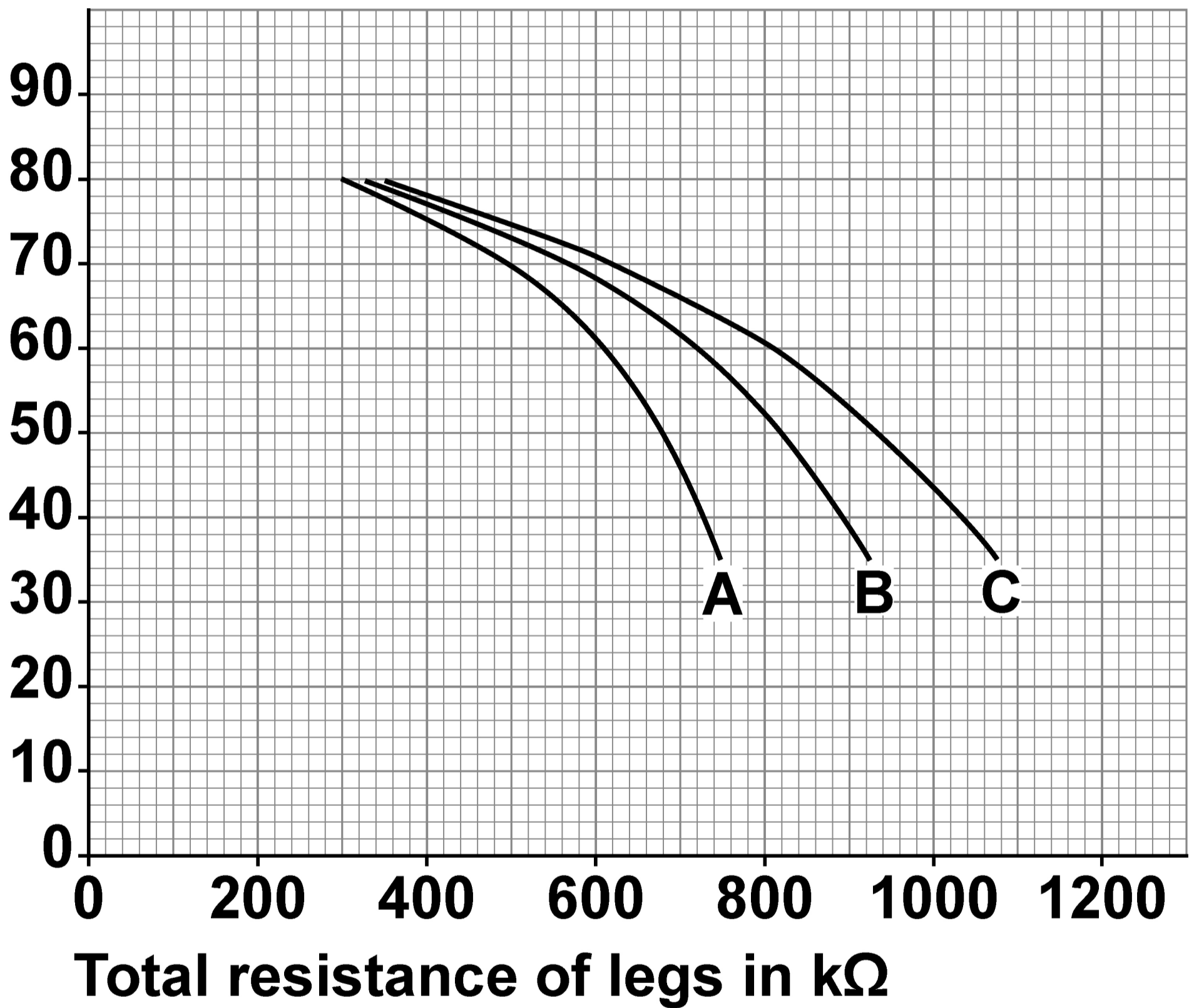
FIGURE 11, on page 76, shows how the scales use the category and the total resistance of the legs to determine the body water percentage.

[Turn over]



FIGURE 11

Body water
percentage



The total resistance of the student's legs is 600 kΩ. A healthy body water percentage is between 45% and 65%.

The different measurements of the mass of the student mean that the student could be in either category A or category B.

Evaluate if the student has a healthy body water percentage. [3 marks]

END OF QUESTIONS



15

Additional page, if required.

Write the question numbers in the left-hand margin.



BLANK PAGE

For Examiner's Use	
Question	Mark
1	
2	
3	
4	
5	
6	
TOTAL	

Copyright information

For confidentiality purposes, all acknowledgements of third-party copyright material are published in a separate booklet. This booklet is published after each live examination series and is available for free download from www.aqa.org.uk.

Permission to reproduce all copyright material has been applied for. In some cases, efforts to contact copyright-holders may have been unsuccessful and AQA will be happy to rectify any omissions of acknowledgements. If you have any queries please contact the Copyright Team.

Copyright © 2023 AQA and its licensors. All rights reserved.

WP/M/NC/Jun23/8464/P/1F/E3

8 0



2 3 6 G 8 4 6 4 / P / 1 F