



Surname _____

Forename(s) _____

Centre Number _____

Candidate Number _____

Candidate Signature _____

I declare this is my own work.

GCSE

COMBINED SCIENCE: TRILOGY

H

Higher Tier

Physics Paper 1H

8464/P/1H

Thursday 25 May 2023

Morning

Time allowed: 1 hour 15 minutes

At the top of the page, write your surname and forename(s), your centre number, your candidate number and add your signature.

[Turn over]



MATERIALS

For this paper you must have:

- **a ruler**
- **a scientific calculator**
- **the Physics Equations Sheet (enclosed).**

INSTRUCTIONS

- **Use black ink or black ball-point pen.**
- **Pencil should be used for drawing.**
- **Answer ALL questions in the spaces provided.**
- **If you need extra space for your answer(s), use the lined pages at the end of this book. Write the question number against your answer(s).**
- **Do all rough work in this book. Cross through any work you do not want to be marked.**
- **In all calculations, show clearly how you work out your answer.**



INFORMATION

- **The maximum mark for this paper is 70.**
- **The marks for questions are shown in brackets.**
- **You are expected to use a calculator where appropriate.**
- **You are reminded of the need for good English and clear presentation in your answers.**

DO NOT TURN OVER UNTIL TOLD TO DO SO



BLANK PAGE



0	1
---	---

Wind power and solar power are both renewable energy resources used to generate electricity for the National Grid.

0	1	.	1
---	---	---	---

Which of the following is also a renewable energy resource? [1 mark]

Tick (✓) ONE box.

Geothermal

Natural gas

Nuclear fuel

[Turn over]



0	1	.	2
---	---	---	---

The energy transferred by the National Grid in one second was 36 gigajoules (GJ).

Which of the following is the same as 36 gigajoules?
[1 mark]

Tick (✓) ONE box.

$36 \times 10^3 \text{ J}$

$36 \times 10^6 \text{ J}$

$36 \times 10^9 \text{ J}$

$36 \times 10^{12} \text{ J}$



BLANK PAGE

[Turn over]



01.3

FIGURE 1 shows how the mean power output from solar and wind energy resources in the UK varied between 2014 and 2019.

FIGURE 1

Mean
power
output
in MW

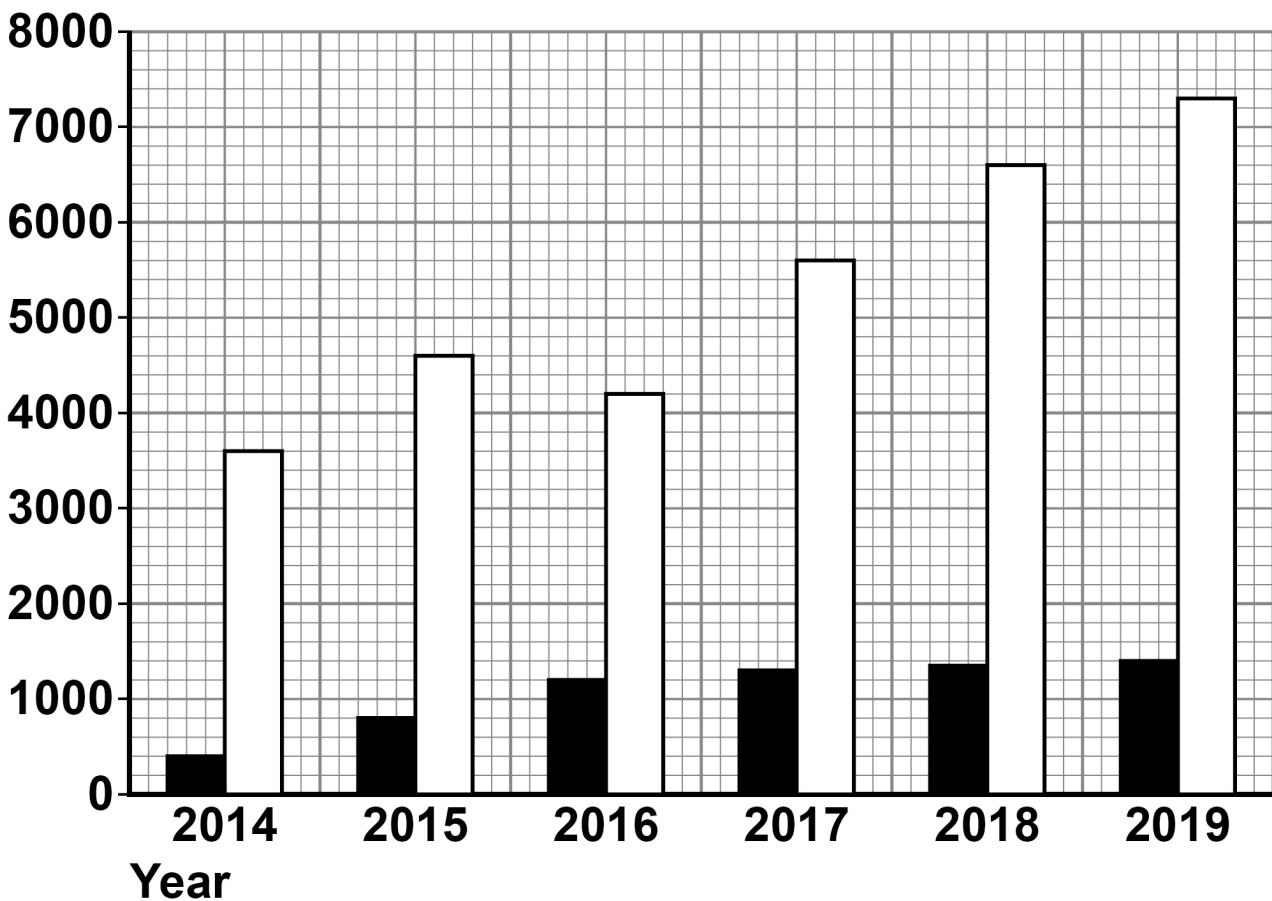
**KEY**

■ Solar power

□ Wind power



FIGURE 2 shows how the power output from solar and wind energy resources varies in a typical year.

FIGURE 2

**Power
output
in MW**

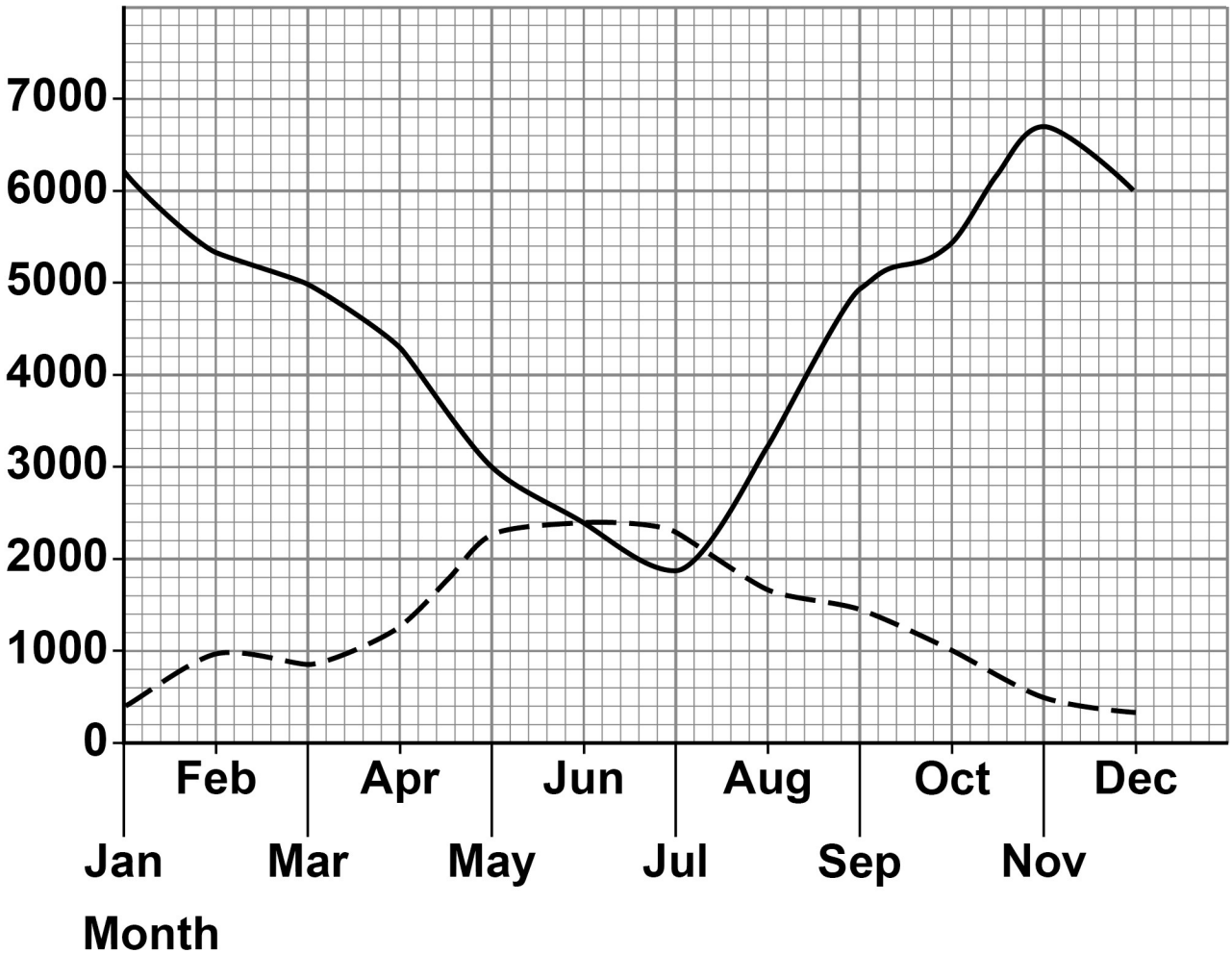

KEY

— Wind power

- - - Solar power

[Turn over]



BLANK PAGE



BLANK PAGE

[Turn over]



02

Body analysis scales use the electrical resistance of a person's legs to estimate the percentage of water in the person's body.

FIGURE 3 shows body analysis scales.

FIGURE 3



The person's legs contain both solid tissue and water.

A student used resistors to model the solid tissue and water.

The student connected a $20\ \Omega$ resistor in parallel with a resistor, R .

FIGURE 4, on the opposite page, shows the circuit diagram.



FIGURE 4

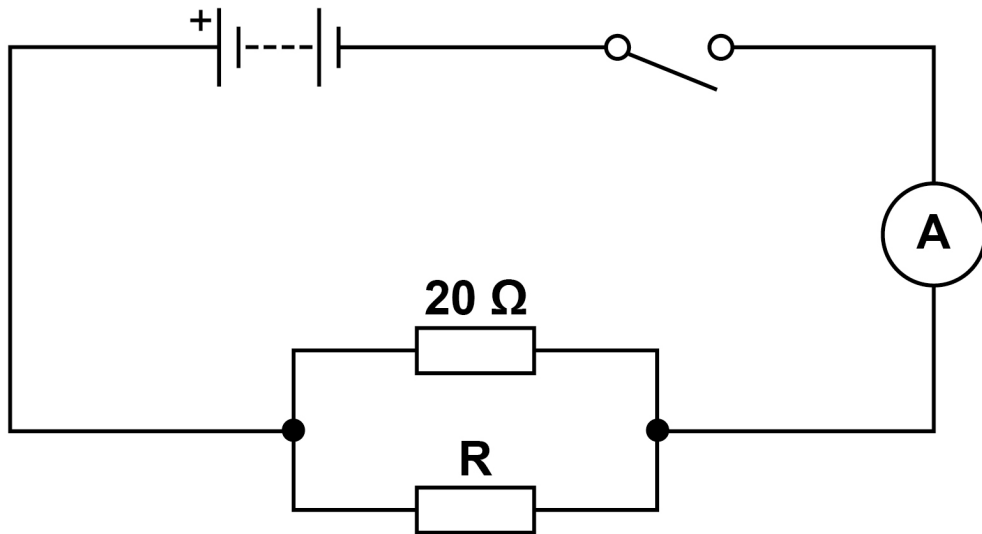

0	2	.	1
---	---	---	---

To determine the total resistance of both resistors, a voltmeter must be connected into the circuit.

Complete FIGURE 4 to show where the voltmeter should be connected. [1 mark]

[Turn over]



0	2	.	2
---	---	---	---

The student calculated the total resistance of the two resistors.

The student's answer was 26Ω .

Explain why the student's answer **CANNOT** be correct.
[2 marks]

Use the Physics Equations Sheet to answer questions 02.3 and 02.4.

02.3

Write down the equation that links current (I), resistance (R) and potential difference (V). [1 mark]

[Turn over]



0	2	.	4
---	---	---	---

When the total resistance of the resistors was 7.5Ω the current in the circuit was 480 mA.

Calculate the potential difference across the two resistors. [3 marks]

Potential difference = _____ V



BLANK PAGE

[Turn over]



The student investigated how the resistance of R affected the total resistance of the circuit.

TABLE 1 shows the results.

TABLE 1

Resistance of R in ohms	Total resistance of the circuit in ohms
5.0	4.0
10.0	6.7
15.0	8.6
20.0	10.0
25.0	11.1

Some of the results are plotted in FIGURE 5, on the opposite page.

0 2 . 5

Complete FIGURE 5, on the opposite page.

You should:

- label both axes
- plot the two remaining values from TABLE 1
- draw the line of best fit.

[3 marks]



FIGURE 5

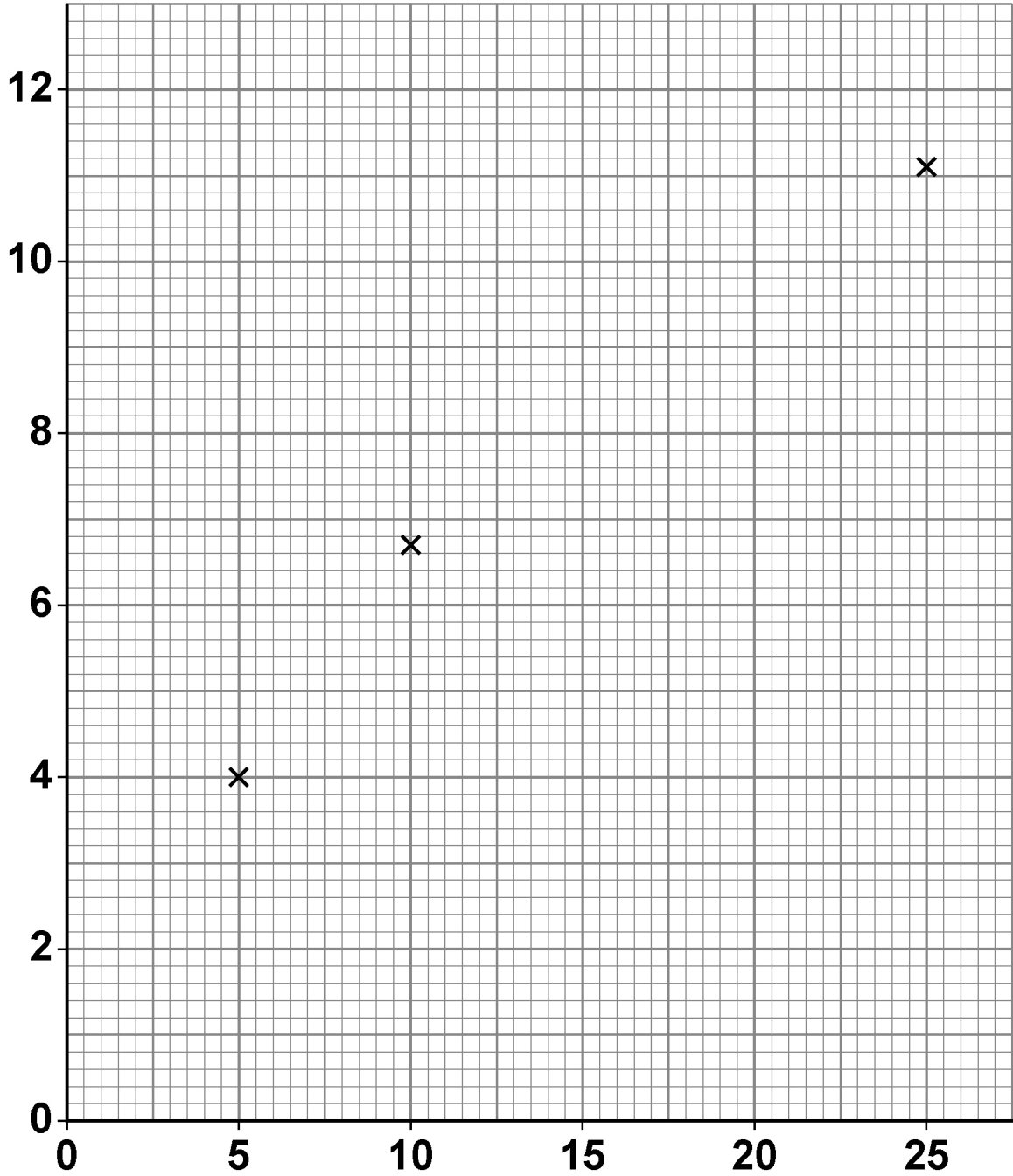

[Turn over]



BLANK PAGE



0	2	.	6
---	---	---	---

What resistance of R would give a total resistance of 4.4Ω ?

Use FIGURE 5, on page 21. [1 mark]

Resistance of R = _____ Ω

[Turn over]



The body analysis scales initially show a reading of 0.0 kg.

When the student steps onto the scales the reading is 64.8 kg.

The student steps off the scales and then immediately steps back on.

The scales now show a reading of 64.1 kg.

0 2 . 7

Complete the sentence. [1 mark]

The difference between the two values given by the scales is due to a _____ error.



0	2	.	8
---	---	---	---

The height of the student is programmed into the scales.

The scales place the student into a category, A, B or C, based on height and mass.

FIGURE 6, on page 26, shows how the scales use the category and the total resistance of the legs to determine the body water percentage.

[Turn over]



FIGURE 6

Body water
percentage

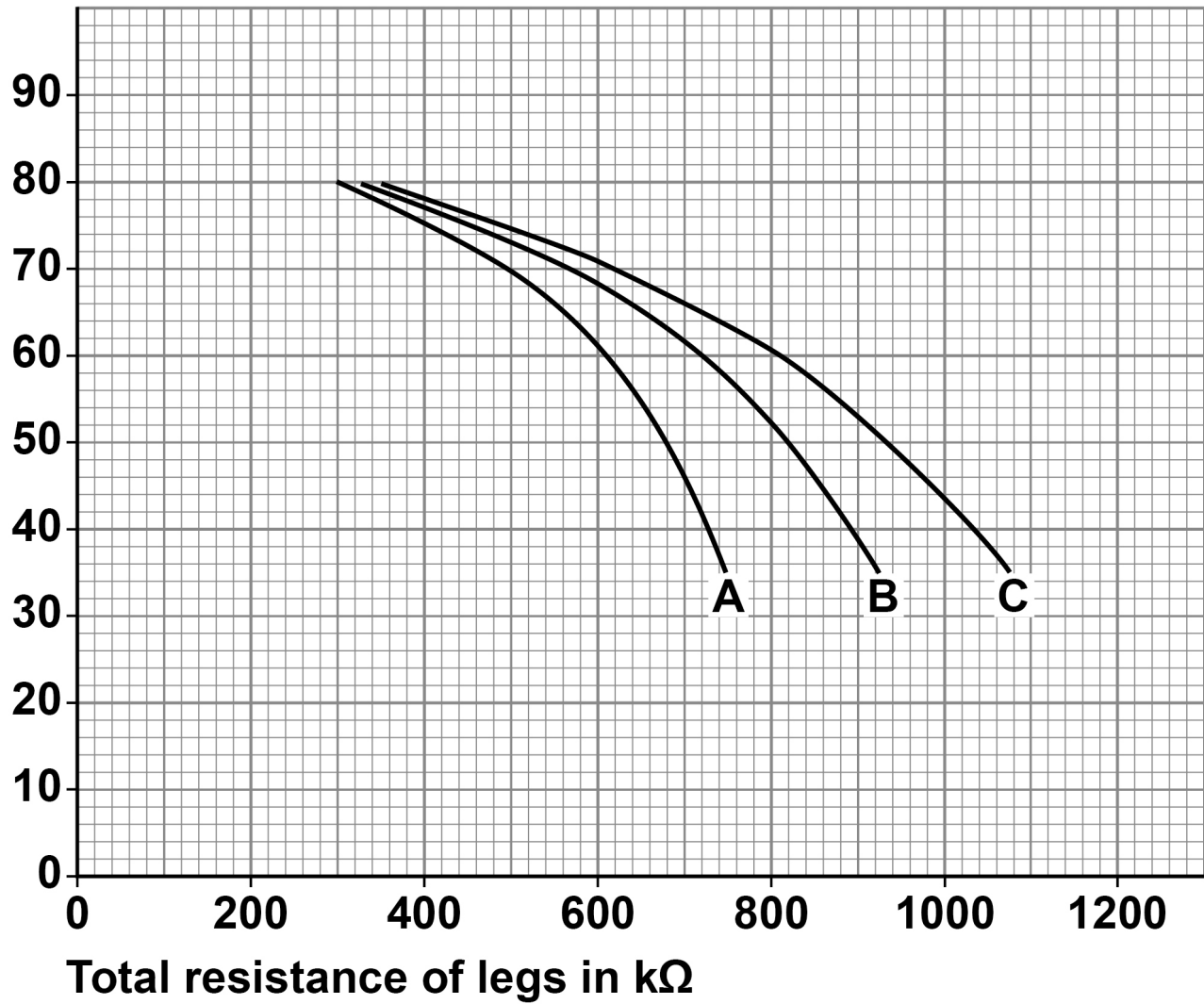

03

FIGURE 7 shows how the National Grid transfers energy from a power station to some street lamps.

FIGURE 7

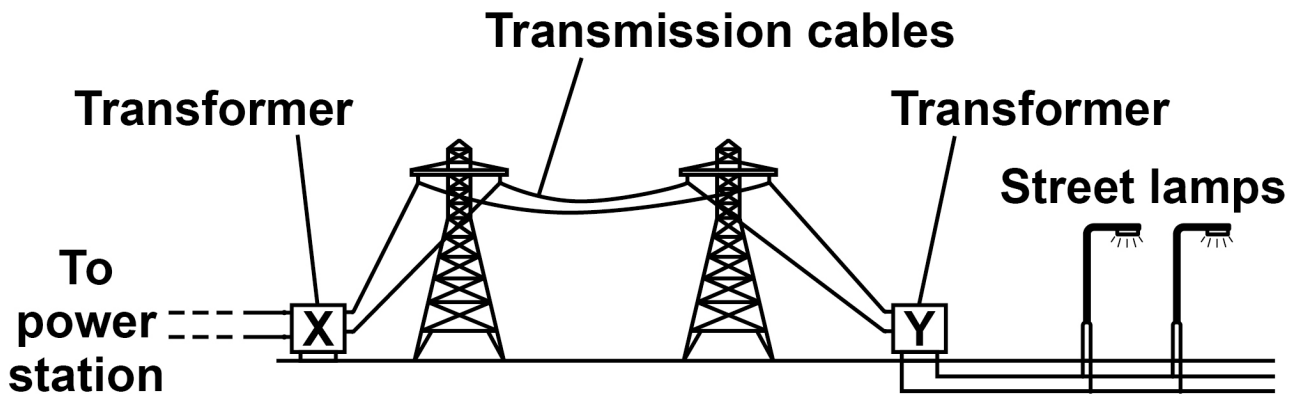

03.1

Explain how transformer X increases the efficiency of the National Grid. [3 marks]



[Turn over]

0	3	.	2
---	---	---	---

The potential difference across the primary coil in transformer Y is 400 000 V.

The potential difference across the secondary coil is 11 000 V.

The current in the primary coil is 660 A.

Calculate the current in the secondary coil of transformer Y.

Use the Physics Equations Sheet. [3 marks]

Current in the secondary coil = _____ A



0	3	.	3
---	---	---	---

Why is the current in each street lamp less than the current in the secondary coil in transformer Y?

[1 mark]

Tick (✓) ONE box.

Current is used up in the cables between Y and each street lamp.

Some of the current is dissipated to the surroundings.

The cables between Y and the street lamps have electrical resistance.

The street lamps are connected in parallel.

[Turn over]



03.4

FIGURE 8 shows the top of a street lamp.

FIGURE 8

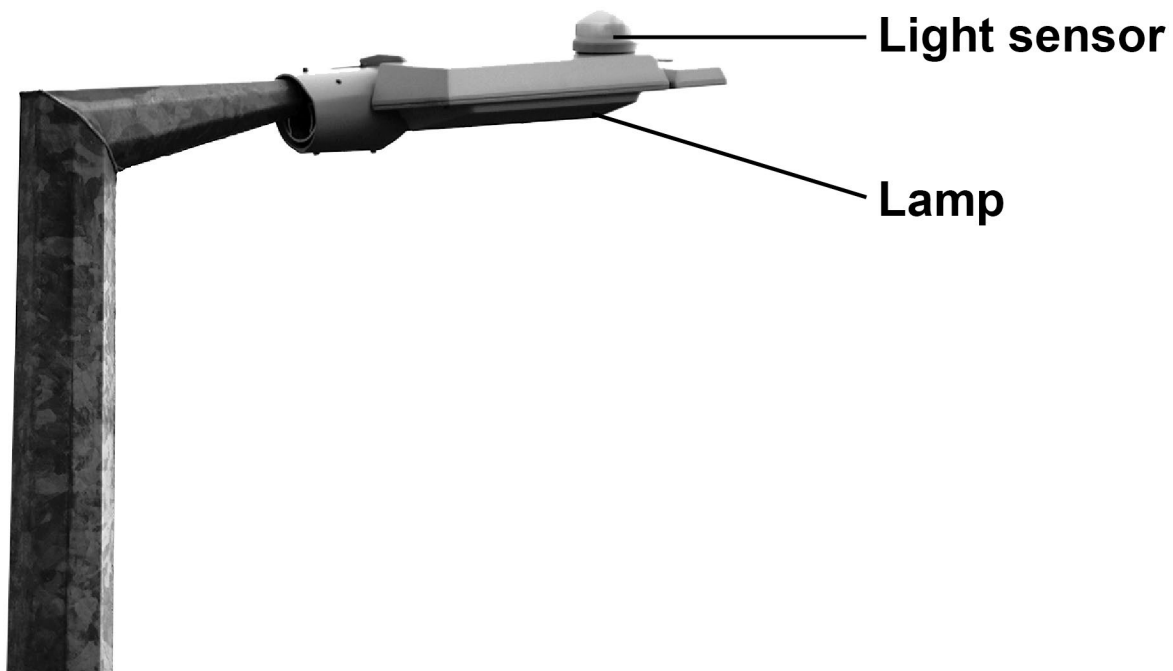

The light sensor detects if it is day or night.

FIGURE 9 shows part of the circuit in the light sensor.

FIGURE 9

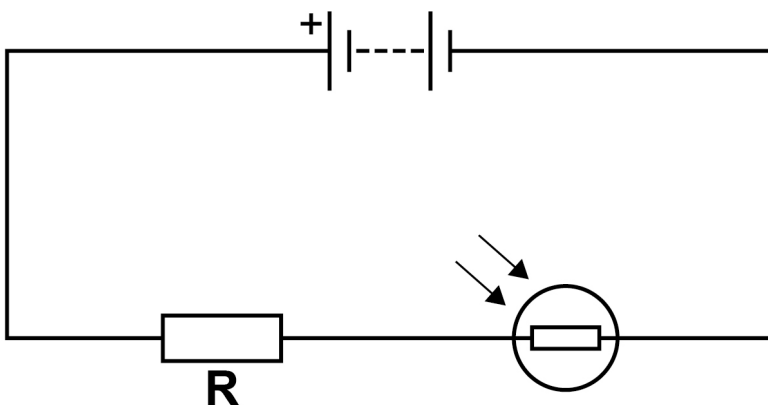

Explain what happens to the potential difference across resistor R as the light intensity decreases. [3 marks]

[Turn over]



0	3	.	5
---	---	---	---

When the current in resistor R is 20 mA, the power transferred by resistor R is 6.0 W.

Calculate the resistance of resistor R.

Use the Physics Equations Sheet. [4 marks]

Resistance = _____ Ω



0	4
---	---

A scientist investigated a sample of a radioactive material to determine if it would be suitable for medical use.

0	4	.	1
---	---	---	---

The method, results and conclusions of the scientist will need to be checked by other scientists before the results of the investigation are published.

What name is given to this checking process? [1 mark]

[Turn over]



04.2

There is an increased risk of cancer if the scientist is irradiated by nuclear radiation.

What property of nuclear radiation causes the increased risk of cancer? [1 mark]

04.3

The activity of a radioactive source is the rate at which the nuclei of the source decay.

What is the unit for the activity of a radioactive source? [1 mark]



0	4	.	4
---	---	---	---

The scientist placed a radiation detector near the sample and measured the count-rate.

Explain why the count-rate is less than the activity of the sample. [2 marks]

[Turn over]



0 4 . 5

The scientist recorded the count-rate from the sample with the radiation detector at different distances from the sample.

TABLE 2 shows the results.

TABLE 2

Distance between the sample and the detector in centimetres	Count-rate in counts/second
2.0	300
5.0	24
10.0	0

Explain which type of radiation was emitted by the sample. [2 marks]



BLANK PAGE

[Turn over]



04.6

The scientist moved the detector closer to the sample and started a stopwatch.

The scientist measured the count-rate from the sample at different times.

TABLE 3 shows some of the results.

TABLE 3

Time in minutes	Count-rate in counts/second
0	1568
30	X
60	98

The scientist realised that 30 minutes is a whole number of half-lives.

Calculate the value of X in TABLE 3. [3 marks]



X = _____ counts/second

[Turn over]



0	4	.	7
---	---	---	---

The scientist had a second sample of the radioactive material.

The scientist made appropriate measurements, then calculated the half-life of each sample.

Why was the half-life calculated from the second sample slightly different from the half-life calculated from the first sample? [1 mark]

Tick (✓) ONE box.

Radioactive decay is a random process.

The count-rate from a radioactive sample is predictable.

The samples were at different temperatures.

The size of each sample was different.

11



0	5
---	---

FIGURE 10 shows a child's toy.

A child pushes down on the toy to compress the spring. The spring then launches the toy into the air.

FIGURE 10

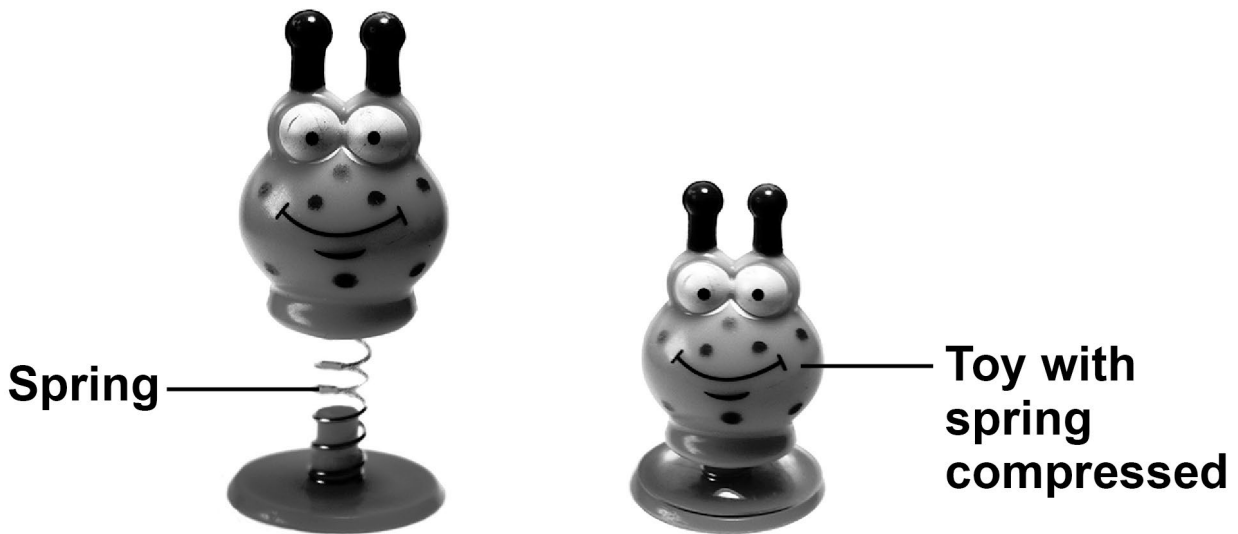

[Turn over]



0	5	.	1
---	---	---	---

A student measured the maximum height reached by the toy.

The student placed a vertical metre rule near the toy, and observed the height reached by the toy.

The student repeated the experiment, observing from a different position.

FIGURE 11 shows the toy at its maximum height and the two positions of the student.

FIGURE 11

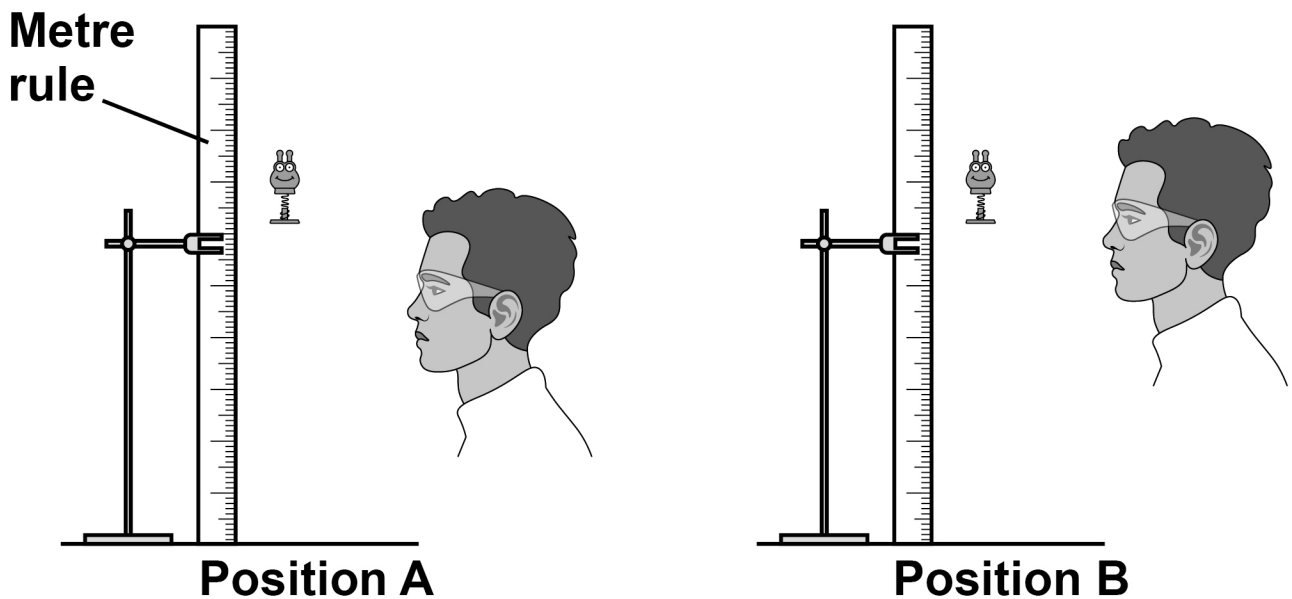

Observing the toy from position B instead of position A affected the measurement of the maximum height reached by the toy.

Explain how. [2 marks]

[Turn over]

0	5	.	2
---	---	---	---

The greatest height reached by the toy was 64 cm.

The gravitational potential energy of the toy at this height was 0.049 J.

gravitational field strength = 9.8 N/kg

Calculate the mass of the toy.

Use the Physics Equations Sheet.

Give your answer to 2 significant figures. [5 marks]

Mass of toy (2 significant figures) =

_____ kg

[Turn over]



0	5	.	3
---	---	---	---

When the spring launches the toy into the air, the temperature of the air increases.

Explain why the child's toy on its own is NOT a closed system. [2 marks]

9



BLANK PAGE

[Turn over]



06

FIGURE 12 shows a device that uses a mug of hot coffee to turn a wheel.

FIGURE 12

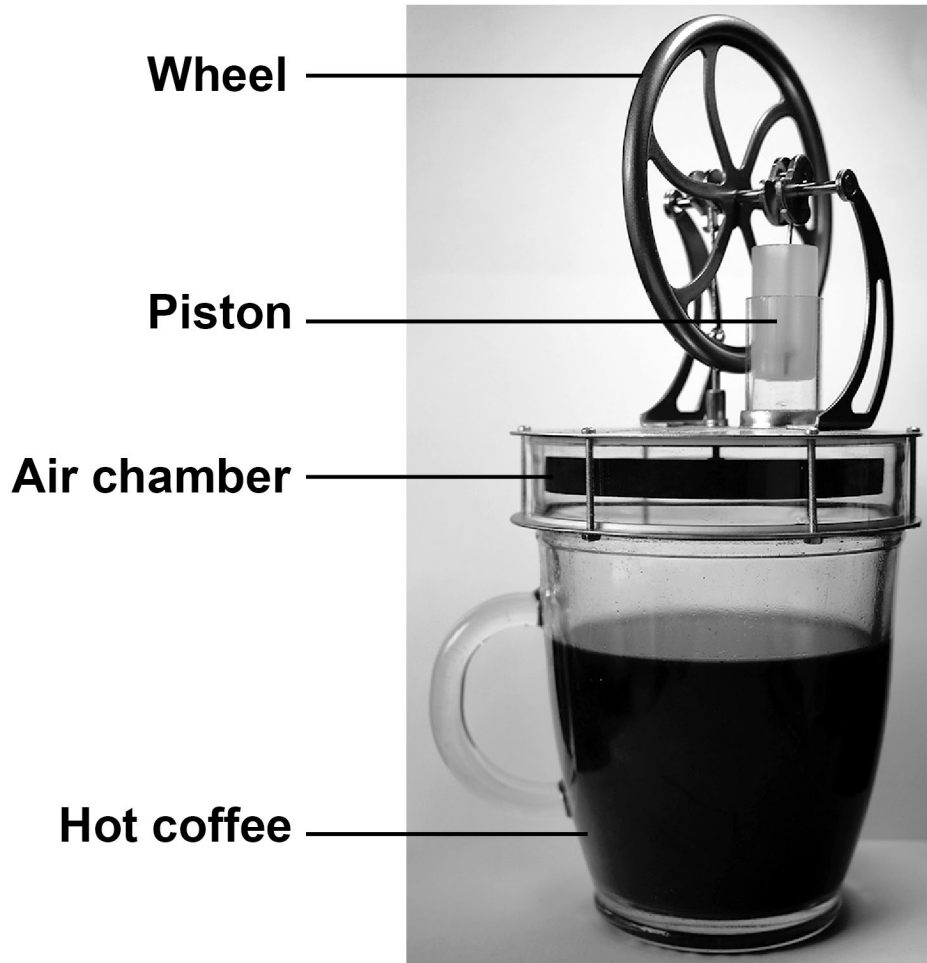

06.1

The hot coffee increases the temperature of the air in the chamber.

Explain how the pressure in the chamber changes.
[3 marks]

[Turn over]



0	6	.	2
---	---	---	---

For the device to work, the air in the chamber must increase in temperature quickly.

Explain why the bottom of the air chamber is made of metal rather than plastic. [2 marks]



0	6	.	3
---	---	---	---

The mass of air in the chamber is constant.

What property of air allows a small change in internal energy to cause a large temperature change to the air in the chamber? [1 mark]

0	6	.	4
---	---	---	---

The changes in pressure in the air chamber cause the wheel to turn.

Suggest ONE way to increase the speed at which the wheel turns. [1 mark]

[Turn over]



0	6	.	5
---	---	---	---

The temperature of the coffee decreases as the device is used.

The initial temperature of the coffee was $76\text{ }^{\circ}\text{C}$.

The internal energy of the coffee decreased by 15 kJ.

density of coffee = $1.1 \times 10^3\text{ kg/m}^3$

volume of coffee = $1.9 \times 10^{-4}\text{ m}^3$

specific heat capacity of coffee = $4200\text{ J/kg }^{\circ}\text{C}$

Calculate the final temperature of the coffee.

Use the Physics Equations Sheet. [6 marks]



Final temperature of the coffee = _____ °C

END OF QUESTIONS

13



Additional page, if required.

Write the question numbers in the left-hand margin.



BLANK PAGE

For Examiner's Use	
Question	Mark
1	
2	
3	
4	
5	
6	
TOTAL	

Copyright information

For confidentiality purposes, all acknowledgements of third-party copyright material are published in a separate booklet. This booklet is published after each live examination series and is available for free download from www.aqa.org.uk.

Permission to reproduce all copyright material has been applied for. In some cases, efforts to contact copyright-holders may have been unsuccessful and AQA will be happy to rectify any omissions of acknowledgements. If you have any queries please contact the Copyright Team.

Copyright © 2023 AQA and its licensors. All rights reserved.

WP/M/NC/Jun23/8464/P/1H/1E3