

Please write clearly in block capitals.

Centre number

Candidate number

Surname \_\_\_\_\_

Forename(s) \_\_\_\_\_

Candidate signature \_\_\_\_\_

I declare this is my own work.

# Functional Skills Level 2

## MATHEMATICS

### Paper 1 Non-Calculator

Tuesday 28 February 2023

Morning

Time allowed: 30 minutes

#### Materials

For this paper you must have:

- mathematical instruments.
- You must **not** use a calculator.

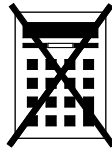

For Examiner's Use	
Question	Mark
1–5	
6	
<b>TOTAL</b>	

#### Instructions

- Use black ink or black ball-point pen. Draw diagrams in pencil.
- Answer **all** questions.
- You must answer the questions in the spaces provided. Do not write outside the box around each page or on blank pages.
- If you need extra space for your answer(s), use the lined pages at the end of this book. Write the question number against your answer(s).
- Do all rough work in this book. Cross through any work you do not want to be marked.
- State the units of your answer where appropriate.

#### Information

- The marks for questions are shown in brackets.
- The maximum mark for this paper is 20.
- You may ask for more answer paper, graph paper and tracing paper. These must be tagged securely to this answer book.

#### Advice

In all calculations, show clearly how you work out your answer.



M A R 2 3 8 3 6 2 1 0 1

**Section A**Answer **all** questions in the spaces provided.**1** Here are six numbers.

10      13      13      15      18      21

Work out the median.  
Circle your answer.**[1 mark]**

11      13      14      15

**2** Work out  $(7 + 3)^2 - 6 \times 4$ **[2 marks]**

---

---

---

---

Answer \_\_\_\_\_



3 Work out the size of angle  $x$ .

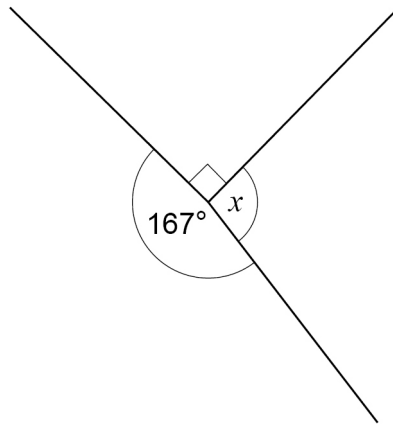

Not drawn  
accurately

[2 marks]

---

---

---

---

---

Answer \_\_\_\_\_<sup>o</sup>

Turn over for the next question

Turn over ►



4 Work out  $3.762 \div 9$

[2 marks]

---

---

---

---

Answer \_\_\_\_\_

5 The probability of an event happening is 83%  
What is the probability of the event **not** happening?

[1 mark]

---

---

---

Answer \_\_\_\_\_ %

8





**6 (b)** Calvin makes the 40 pieces of fudge.

He covers

14 of the pieces in white chocolate

the remaining pieces in milk chocolate.

What fraction of the pieces does he cover in **milk** chocolate?

Give your answer in its simplest form.

**[3 marks]**

---

---

---

---

---

---

---

---

---

---

Answer \_\_\_\_\_



- 6 (c)** Calvin puts some of the fudge into a gift box.  
The box is a triangular prism.

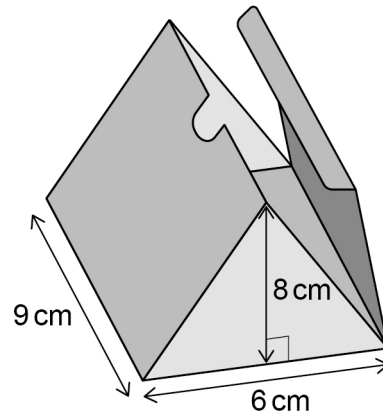

To work out the volume of the box, he follows these steps.

**Step 1** Work out the area of the triangular face.

**Step 2** Multiply the answer to **Step 1** by the length of the box.

For this box, each piece of fudge needs  $10 \text{ cm}^3$  of space.

How many pieces of fudge can Calvin fit in the box?

**[4 marks]**

---



---



---



---



---



---



---



---



---



---



---



---



---



---



---



---

Answer \_\_\_\_\_

**END OF QUESTIONS**



**There are no questions printed on this page**

*Do not write  
outside the  
box*

**DO NOT WRITE ON THIS PAGE  
ANSWER IN THE SPACES PROVIDED**











**There are no questions printed on this page**

*Do not write  
outside the  
box*

**DO NOT WRITE ON THIS PAGE  
ANSWER IN THE SPACES PROVIDED**

**Copyright information**

For confidentiality purposes, all acknowledgements of third-party copyright material are published in a separate booklet. This booklet is published after each live examination series and is available for free download from [www.aqa.org.uk](http://www.aqa.org.uk).

Permission to reproduce all copyright material has been applied for. In some cases, efforts to contact copyright-holders may have been unsuccessful and AQA will be happy to rectify any omissions of acknowledgements. If you have any queries please contact the Copyright Team.

Copyright © 2023 AQA and its licensors. All rights reserved.



1 2



2 3 3 G 8 3 6 2 / 1

IB/M/Mar23/8362/1